

# GL3820

## VIDEO SWITCH

### Description

This integrated circuit provides all video switching allowing connections between the peri TV plug and video sections in the TV set.

### Features

- 1 Video Output  $75\ \Omega$  -  $1\ V_{pp}$  No Switched
- 1 Switched Video Output  $2\ V_{pp}$
- Video Cross Talk : 50 dB Typical
- Short Circuit Protection of Inputs and Outputs
- Clamped Video Inputs

### Pin Configuration

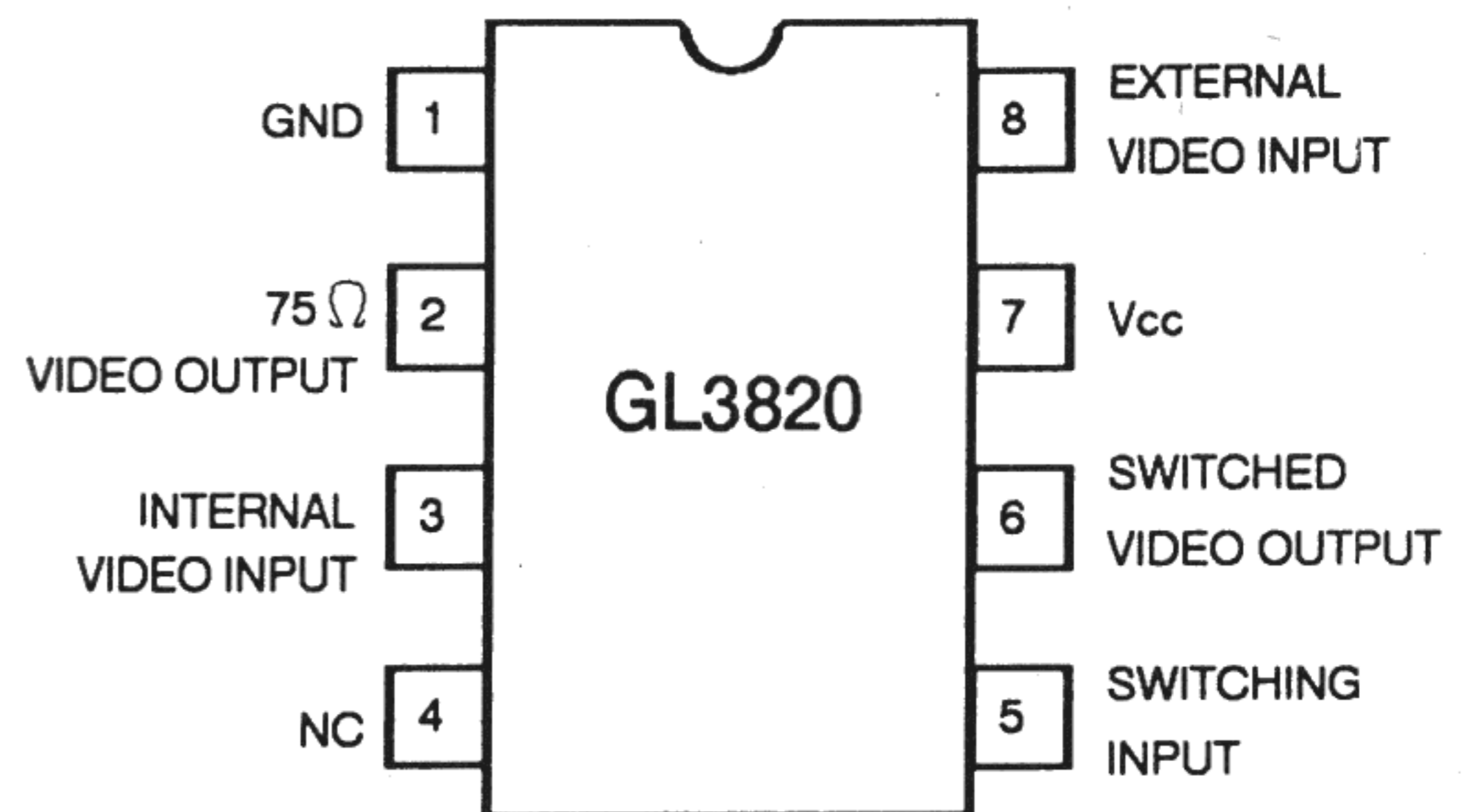

### Maximum Ratings

RATING	SYMBOL	VALUE	UNIT
Supply Voltage	$V_{cc}$	18	V
Operating Temperature with Load $> 150\ \Omega$ with Load $= 75\ \Omega$	$T_{opr}$	- 10 to + 100	$^{\circ}C$
		- 10 to + 70	
Junction Temperature	$T_j$	- 40 to + 150	$^{\circ}C$
Storage Temperature	$T_{stg}$	- 40 to + 150	$^{\circ}C$
Minimum DC Load Resistor $P_6$		600	$\Omega$
Minimum DC Load Resistor $P_2$		75	$\Omega$

### Typical Application and Test Circuit

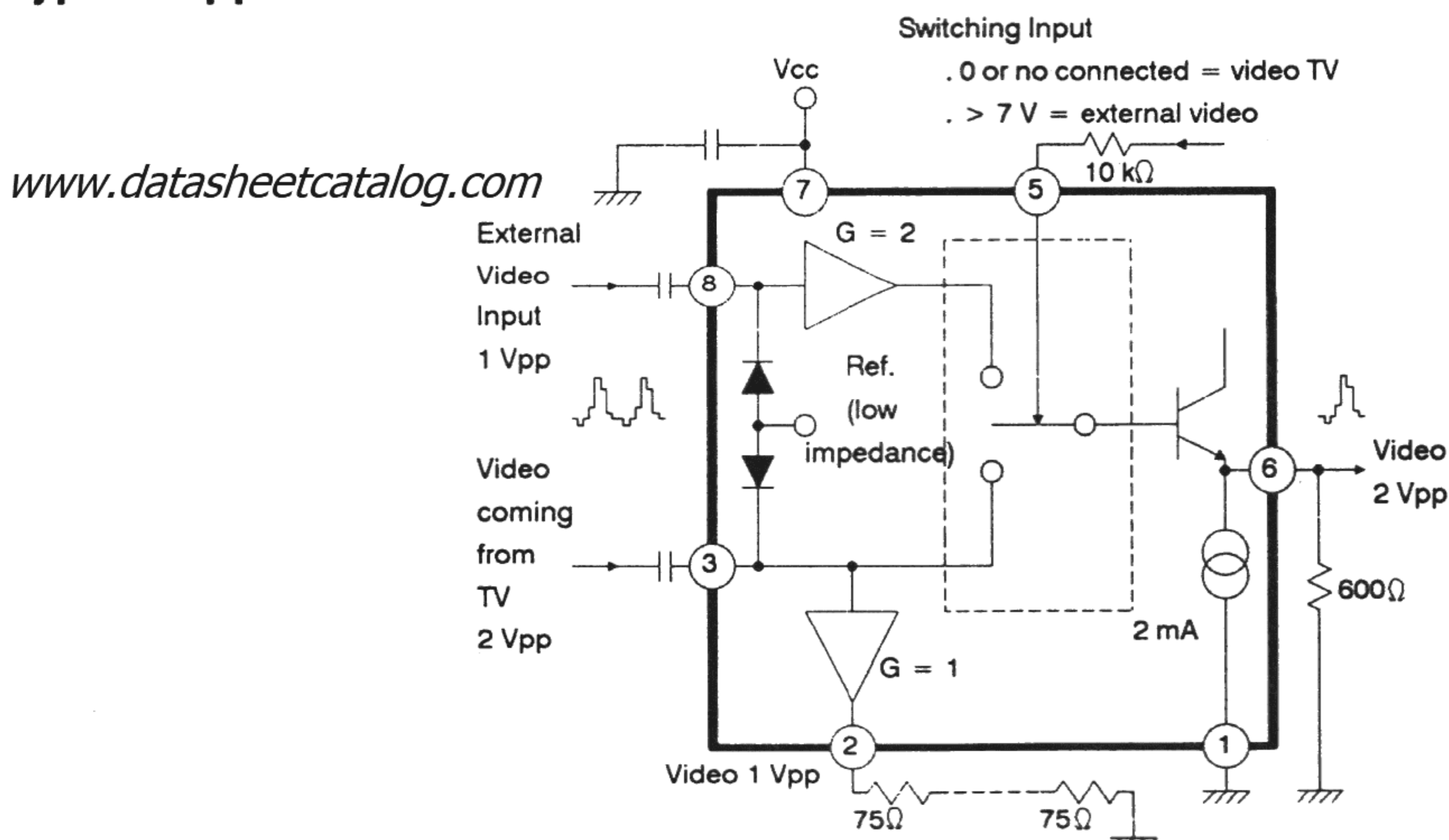

Note : We advice to protect the  $75\ \Omega$  output through a  $75\ \Omega$  resistor for supply voltage upper than 9 V.

**Electrical Characteristics** :  $T_a = + 25\text{ }^\circ\text{C}$ ,  $V_{CC} = 9\text{ V}$  (unless otherwise noted)

CHARACTERISTIC	SYMBOL	MIN	TYP	MAX	UNIT
Supply Voltage Range	$V_{CC}$	8	-	14	V
Supply Current (no load on pin 2 and pin 6)	$I_{CC}$	-	-	20	mA
Supply Current (with $75\ \Omega$ between pin 2-1, with $600\ \Omega$ between pin 6-1)	$I_{CC}$	-	75	-	mA
Total Power Dissipation with Load	$P_{tot}$	-	450	-	mW
Internal Video Input Swing from PIF (positive video)	-	-	-	4.5	$V_{pp}$
Internal Video Input Impedance (positive video)	-	50	-	-	$k\Omega$
Internal Video Input Bias Current (positive video)	-	10	25	40	$\mu\text{A}$
External Video Input Swing (positive video)	-	-	-	2	$V_{pp}$
External Video Input Impedance (positive video)	-	50	-	-	$k\Omega$
Switched Video Output Swing	-	-	-	4.5	$V_{pp}$
Switched Video Output Dynamic Impedance	-	-	-	20	$\Omega$
Switched Video DC Output Voltage (sync. pulse level, note) ( $600\ \Omega$ )	-	1.7	2	2.4	V
Switched Video Band Width (- 1 dB)	-	6	-	-	MHz
Switched Video Output Gain					
Pin 6 - Pin 8 (gain with $600\ \Omega$ load)	-	+ 5	+ 6	+7	dB
Pin 6 - Pin 3 (gain with $600\ \Omega$ load)	-	- 1	- 0.5	0	
External Video Output Swing (with $75\ \Omega$ load)	-	-	2	2.2	V
External Video Dynamic Output Impedance	-	-	10	-	$\Omega$
External Video DC Output Voltage (sync. pulse level, note) ( $75\ \Omega$ )	-	1.7	2	2.4	V
External Video Output Gain (pin 2 - pin 3 gain with $75\ \Omega$ load)	-	- 1.8	- 1	- 0.4	dB
Switching Input Unactive Low Level or Unconnected Pin (TV receiving)	-	0	-	3	V
Switching Input Active Level (ext. receiving)	-	7	-	$V_{CC}$	V
Switching Input Impedance	-	10	-	-	$k\Omega$
Video Rejection between Two Inputs					
0 to 5 MHz	-	-	- 50	-	dB
1 kHz	-	- 50	-	-	
Differential Group Delay	-	-	15	-	ns
Linearity Distortion					%
Luma	-	-	2	-	
Chroma	-	-	2	-	
Intermodulation Luma - Chroma	-	-	5	-	
Supply Voltage Rejection (1 kHz)	-	40	50	-	dB

Note : Use a video signal with a synchro pulse in order to make the clamp work in a correct way ( $75\ \Omega$  to the ground and  $10\ \mu\text{F}$  in series).