



element14

EN - For pricing and availability in your local country please visit one of the below links:

DE - Informationen zu Preisen und Verfügbarkeit in Ihrem Land erhalten Sie über die unten aufgeführten Links:

FR - Pour connaître les tarifs et la disponibilité dans votre pays, cliquez sur l'un des liens suivants:

[GL6100](#)

EN

This Datasheet is presented by
the manufacturer

DE

Dieses Datenblatt wird vom
Hersteller bereitgestellt

FR

Cette fiche technique est
présentée par le fabricant



GL61x0 Product Technical Specification and User Guide

AirLink GL Series



SIERRA
WIRELESS

WA_DEV_GL6100_PTS_001
004
November 30, 2010

Important Notice

Due to the nature of wireless communications, transmission and reception of data can never be guaranteed. Data may be delayed, corrupted (i.e., have errors) or be totally lost. Although significant delays or losses of data are rare when wireless devices such as the Sierra Wireless modem are used in a normal manner with a well-constructed network, the Sierra Wireless modem should not be used in situations where failure to transmit or receive data could result in damage of any kind to the user or any other party, including but not limited to personal injury, death, or loss of property. Sierra Wireless accepts no responsibility for damages of any kind resulting from delays or errors in data transmitted or received using the Sierra Wireless modem, or for failure of the Sierra Wireless modem to transmit or receive such data.

Safety and Hazards

Do not operate the Sierra Wireless modem in areas where blasting is in progress, where explosive atmospheres may be present, near medical equipment, near life support equipment, or any equipment which may be susceptible to any form of radio interference. In such areas, the Sierra Wireless modem **MUST BE POWERED OFF**. The Sierra Wireless modem can transmit signals that could interfere with this equipment. Do not operate the Sierra Wireless modem in any aircraft, whether the aircraft is on the ground or in flight. In aircraft, the Sierra Wireless modem **MUST BE POWERED OFF**. When operating, the Sierra Wireless modem can transmit signals that could interfere with various onboard systems.

Note: Some airlines may permit the use of cellular phones while the aircraft is on the ground and the door is open. Sierra Wireless modems may be used at this time.

The driver or operator of any vehicle should not operate the Sierra Wireless modem while in control of a vehicle. Doing so will detract from the driver or operator's control and operation of that vehicle. In some states and provinces, operating such communications devices while in control of a vehicle is an offence.

Limitations of Liability

This manual is provided "as is". Sierra Wireless makes no warranties of any kind, either expressed or implied, including any implied warranties of merchantability, fitness for a particular purpose, or noninfringement. The recipient of the manual shall endorse all risks arising from its use.

The information in this manual is subject to change without notice and does not represent a commitment on the part of Sierra Wireless. SIERRA WIRELESS AND ITS AFFILIATES SPECIFICALLY DISCLAIM LIABILITY FOR ANY AND ALL DIRECT, INDIRECT, SPECIAL, GENERAL, INCIDENTAL, CONSEQUENTIAL, PUNITIVE OR EXEMPLARY DAMAGES INCLUDING, BUT NOT LIMITED TO, LOSS OF PROFITS OR REVENUE OR ANTICIPATED PROFITS OR REVENUE ARISING OUT OF THE USE OR INABILITY TO USE ANY SIERRA WIRELESS PRODUCT, EVEN IF SIERRA WIRELESS AND/OR ITS AFFILIATES HAS BEEN ADVISED OF THE POSSIBILITY OF SUCH DAMAGES OR THEY ARE FORESEEABLE OR FOR CLAIMS BY ANY THIRD PARTY.

Notwithstanding the foregoing, in no event shall Sierra Wireless and/or its affiliates aggregate liability arising under or in connection with the Sierra Wireless product, regardless of the number of events, occurrences, or claims giving rise to liability, be in excess of the price paid by the purchaser for the Sierra Wireless product.

Patents

This product may contain technology developed by or for Sierra Wireless Inc.

This product includes technology licensed from QUALCOMM® 3G.



This product is manufactured or sold by Sierra Wireless Inc. or its affiliates under one or more patents licensed from InterDigital Group.

Copyright

© 2010 Sierra Wireless. All rights reserved.

Trademarks

AirCard® and Watcher® are registered trademarks of Sierra Wireless. Sierra Wireless™, AirPrime™, AirLink™, AirVantage™ and the Sierra Wireless logo are trademarks of Sierra Wireless.

wavecom™,  Open AT,  inSIM®, WAVECOM®, WISMO®, Wireless Microprocessor®, Wireless CPU®, Open AT® are filed or registered trademarks of Sierra Wireless S.A. in France and/or in other countries.

Windows® and Windows Vista® are registered trademarks of Microsoft Corporation.

Macintosh and Mac OS are registered trademarks of Apple Inc., registered in the U.S. and other countries.

QUALCOMM® is a registered trademark of QUALCOMM Incorporated. Used under license.

Other trademarks are the property of the respective owners.

Contact Information

Sales Desk:	Phone:	1-604-232-1488
	Hours:	8:00 AM to 5:00 PM Pacific Time
	E-mail:	sales@sierrawireless.com
Post:	Sierra Wireless 13811 Wireless Way Richmond, BC Canada V6V 3A4	
Fax:	1-604-231-1109	
Web:	www.sierrawireless.com	

Consult our website for up-to-date product descriptions, documentation, application notes, firmware upgrades, troubleshooting tips, and press releases: www.sierrawireless.com

Document History

Version	Date	Updates
001	March 15, 2010	Creation
002	May 24, 2010	Update power consumption values in sections 1.1 and 12.3 GL6110 Power Consumption.
		Updated TBC items throughout the document.
		Updated Appendix B: Product Labeling.
		Updated Table 53 Operating Class Temperature Range.
		Added section 13.4 Reliability Prediction Model.
		Updated Figure 26 Serial Link Implementation for a 4-wire UART and Figure 27 Serial Link Implementation for a 2-wire UART.
		Updated the description for entering Sleep Idle Mode and Serial Port Auto Shut Down Feature .
		Updated data feature from 14.400 bits/s to 14, 400 bits/s .
		Updated document reference from Firmware 7.4a to Firmware 7.42.
		Updated Table 62 Applicable Standards and Requirements for the GL61x0.
		Removed document reference [9].
003	July 12, 2010	Updated Table 18 SIM Interface Electrical Characteristics.
004	October 21, 2010	Updated the storage temperature range in Table 53 Operating Class Temperature Range.
		Removed GL6110 Embedded SIM information throughout the document.
		Added section 12.2 GL6100 Embedded SIM Power Consumption.
		Reverted Table 18 SIM Interface Electrical Characteristics to its original values.
	November 24, 2010	Deleted section 12.2 GL6100 Power Consumption.
		Updated the Standard row in Table 4 from small MS to normal MS.
	November 30, 2010	Updated the Operating Mode information in Table 46, Table 47, Table 48 and Table 50.



Contents

1. OVERVIEW.....	12
1.1. Variants.....	12
1.1.1. Ordering Information.....	12
1.1.2. Shipment Configuration.....	12
1.2. Overall Dimensions.....	13
1.3. GSM/GPRS Features	13
1.4. Connectors.....	13
1.5. Interfaces	14
1.6. Environmental Compliance	14
1.6.1. RoHS Compliance	14
1.6.2. Disposing of the Product.....	14
2. GL61X0 FEATURE SET.....	15
2.1. Supported Bands.....	16
2.2. Protection	16
2.2.1. Power Supply	16
2.2.1.1. GL6100 – UART Version.....	16
2.2.1.2. GL6110 – USB Version.....	16
2.2.2. Electrostatic Discharge	17
2.2.3. Main Serial Link and USB Connection.....	17
2.2.4. SIM Interfaces	17
3. GL61X0 CABLES AND ACCESSORIES	18
3.1. Adaptive Cable (for the GL6100).....	18
3.1.1. 8-pin Micro-Fit Edge.....	18
3.1.2. DB9 Edge.....	19
3.1.3. 2-pin Micro-Fit Edge.....	20
3.5. Micro-fit [®] USB Cable (for the GL6110)	23
3.6. FME Antenna	25
4. FUNCTIONAL SPECIFICATIONS.....	26
4.1. Functional Architecture	26
4.1.1. GL6100 Functional Architecture.....	26
4.1.2. GL6110 Functional Architecture.....	27
4.2. RF Functionalities.....	28
4.3. Operating System.....	28
5. TECHNICAL SPECIFICATIONS	29
5.1. Power Supply	29
5.1.1. GL6100 – UART Version	29

5.1.2.	GL6110 – USB Version.....	30
5.2.	Mechanical Specifications.....	30
5.2.1.	Mechanical Drawing.....	30
5.2.2.	Mechanical Constraints.....	32
5.2.2.1.	Micro-Fit Connector.....	32
5.2.2.2.	FME Connector.....	32
6.	INTERFACES AND PERIPHERALS.....	33
6.1.	Front Interface.....	33
6.1.1.	SIM Interface.....	33
6.1.1.1.	SIM Socket Pin Description.....	34
6.1.2.	LED Status Indicator.....	35
6.2.	Back Interface.....	36
6.2.1.	8-pin Micro-Fit Connector.....	36
6.2.1.1.	Power Supply Connection.....	39
6.2.1.2.	Setup Communications with the GL6100: Main Serial Link Connection (RS-232).....	39
6.2.1.3.	Setup Communications with the GL6110: USB Connection.....	43
6.2.2.	RF Interface.....	43
6.2.2.1.	RF Performances.....	44
6.2.2.2.	Antenna Specifications.....	44
7.	USING THE GL61X0.....	45
7.1.	Getting Started.....	45
7.1.1.	Inserting the SIM Card.....	46
7.1.2.	Extracting the SIM Card.....	47
7.2.	Operational Status.....	47
8.	COMMUNICATING WITH THE GL61X0.....	48
8.1.	Communications Testing for the GL61x0.....	48
8.2.	Verifying the Received Signal Strength.....	49
8.3.	Verifying the Network Registration.....	49
8.4.	Checking the Band Selection.....	50
8.5.	Switching Bands.....	50
8.6.	Checking the PIN Code Status.....	51
8.7.	Main AT Commands for the GL6100.....	51
8.8.	Echo Function.....	52
9.	USING THE GL6110 WITH EMBEDDED SIM.....	53
9.1.	Operation.....	53
9.2.	Switching Between Embedded SIM and an External SIM.....	53
9.3.	Software Configuration.....	54
10.	GL61X0 MAINTENANCE.....	55
10.1.	Enabling/Disabling the Flash LED.....	55
10.2.	Resetting the GL61x0.....	55
10.3.	Operating System Upgrade Procedure.....	55
11.	TROUBLESHOOTING THE GL61X0.....	56

11.1.	GL6100 – RS232 Version	56
11.1.1.	No Communications with the GL6100 through the Serial Link.....	56
11.2.	GL6110 – USB Version.....	57
11.2.1.	No Communications with the GL6110 through the USB.....	57
11.3.	Receiving “ERROR”	57
11.4.	Receiving “NO CARRRIER”	58
12.	POWER CONSUMPTION	60
12.1.	Various Operating Modes	60
12.1.1.	Entering Sleep Idle Mode (only available on GL6100)	61
12.1.1.1.	Using AT+W32K = 1	61
12.1.1.2.	Using AT+W32K = 1,0	61
12.1.2.	Entering Active/Sleep Mode.....	61
12.2.	GL6100 Embedded SIM Power Consumption	62
12.2.1.	Power Consumption without the Sierra Wireless Software Suite.....	62
12.3.	GL6110 Power Consumption	64
12.3.1.	Power Consumption without the Sierra Wireless Software Suite.....	64
12.4.	Consumption Measurement Procedure	65
12.4.1.	Hardware Configuration	66
12.4.1.1.	Equipment.....	66
12.4.1.2.	SIM Cards Used	67
12.4.2.	Software Configuration	67
12.4.2.1.	GL61x0 Configuration.....	67
12.4.2.2.	Equipment Configuration.....	67
13.	RELIABILITY STANDARDS: COMPLIANCE AND RECOMMENDATIONS	69
13.1.	Reliability Compliance.....	69
13.2.	Applicable Standards Listing.....	69
13.3.	Environmental Specifications	70
13.3.1.	Function Status Classification	71
13.4.	Reliability Prediction Model	71
13.4.1.	Life Stress Test.....	71
13.4.2.	Environmental Resistance Stress Test.....	72
13.4.3.	Corrosive Resistance Stress Test	72
13.4.4.	Thermal Resistance Cycle Stress Test.....	73
13.4.5.	Mechanical Resistance Stress Tests.....	73
13.4.6.	Handling Resistance Stress Tests.....	75
14.	RECOMMENDATIONS WHEN USING THE GL61X0 ON TRUCKS.....	76
14.1.	Recommended Power Supply Connection on Trucks	76
14.2.	Technical Constraints on Trucks	77
15.	CERTIFICATION COMPLIANCE AND RECOMMENDED STANDARDS	78
15.1.	Certification Compliance	78
15.2.	Applicable Standards Listing.....	78
16.	EMBEDDED PERIPHERALS	80
16.1.	I/O Connector	80

16.2.	SIM Card Socket	80
17.	RECOMMENDED CONNECTORS.....	81
17.1.	GSM Antenna.....	81
18.	REFERENCE DOCUMENTS.....	82
18.1.	Sierra Wireless Software Documentation	82
18.2.	Firmware Documentation.....	82
18.3.	Other Related Documentation.....	83
18.4.	General Reference Documentation	83
19.	LIST OF ABBREVIATIONS.....	84
20.	APPENDIX A: PACKAGING	87
20.1.	GL6100 2-Cable Package (antenna included).....	87
20.3.	GL6110 Package.....	90
21.	APPENDIX B: PRODUCT LABELING	91
21.1.	Model and MSN Label	91
21.2.	IMEI and Approval Label.....	92
22.	APPENDIX C: SAFETY RECOMMENDATIONS (FOR INFORMATION ONLY).....	93
22.1.	RF Safety	93
22.1.1.	General	93
22.1.2.	Exposure to RF Energy.....	93
22.1.3.	Efficient Terminal Operation.....	93
22.1.4.	Antenna Care and Replacement	93
22.2.	General Safety.....	94
22.2.1.	Driving	94
22.2.2.	Electronic Devices	94
22.2.3.	Vehicle Electronic Equipment.....	94
22.2.4.	Medical Electronic Equipment	94
22.2.5.	Aircraft.....	94
22.2.6.	Children.....	95
22.2.7.	Blasting Areas	95
22.2.8.	Potentially Explosive Atmospheres.....	95



List of Figures

Figure 1.	GL61x0 Plug & Play Modem	13
Figure 2.	Adaptive Cable Fuse	16
Figure 3.	Adaptive Cable for the GL6100	18
Figure 4.	8-pin Micro-Fit Edge of the Adaptive Cable	18
Figure 5.	DB9 Edge of the Adaptation Cable.....	19
Figure 6.	2-pin Micro-Fit Edge of the Adaptive Cable	20
Figure 7.	Pin Assignment of the 2-pin Micro-Fit Edge.....	20
Figure 8.	DB9 Cable.....	21
Figure 9.	Pin Assignment of the DB9 Cable	21
Figure 13.	Micro-fit [®] USB Cable.....	23
Figure 14.	USB Connector on Micro-fit [®] USB Cable.....	24
Figure 15.	FME Antenna	25
Figure 16.	GL6100 Functional Architecture	26
Figure 17.	GL6110 Functional Architecture	27
Figure 18.	GL61x0 Mechanical Drawing	31
Figure 19.	GL61x0 Front Interface	33
Figure 20.	LED State During Reset and Initialization Time	35
Figure 21.	GL61x0 Back Interface	36
Figure 22.	8-pin Micro-Fit Connector on Cable Side.....	36
Figure 23.	Pin Assignment of the 8-pin Micro-Fit Connector on GL61x0.....	37
Figure 24.	RS-232 Serial Link Signals	39
Figure 25.	Serial Link Implementation for a 5-wire UART	41
Figure 26.	Serial Link Implementation for a 4-wire UART	41
Figure 27.	Serial Link Implementation for a 2-wire UART	42
Figure 28.	USB Signals on the USB Type A Connector.....	43
Figure 29.	Typical Hardware Configuration for Power Consumption Measurement.....	66
Figure 30.	Recommended Power Supply Connection on Trucks	76
Figure 31.	Example of an Electrical Connection Which May Damage the GL61x0.....	77
Figure 32.	GL61x0 Model and MSN Label	91
Figure 33.	GL61x0 IMEI and Approval Label.....	92



List of Tables

Table 1.	GL61x0 Variants with Corresponding PNMKT	12
Table 2.	GL61x0 Shipment Configuration	12
Table 3.	GL61x0 Physical Dimensions.....	13
Table 4.	GL61x0 Feature Set	15
Table 5.	8-pin Micro-Fit Connector Pin Description	19
Table 6.	DB9 Connector Pin Description.....	19
Table 7.	2-pin Micro-Fit Connector Pin Description	20
Table 8.	DC Cable Pin Description	22
Table 9.	8-pin Micro-Fit Connector Pin Assignment	24
Table 10.	USB Pin Assignment	24
Table 11.	FME Antenna Characteristics.....	25
Table 12.	Supported RF Frequencies	28
Table 13.	Power Supply Electrical Characteristics	29
Table 14.	Effects of Power Supply Defect for the GL6100.....	29
Table 15.	Effects of Power Supply Defect for the GL6100.....	30
Table 16.	Micro-Fit Connector Mechanical Constraints	32
Table 17.	FME RF Connector Mechanical Constraints.....	32
Table 18.	SIM Interface Electrical Characteristics	34
Table 19.	SIM Interface Pin Description.....	34
Table 20.	GL61x0 LED Status	35
Table 21.	8-pin Micro-Fit Connections	36
Table 22.	8-pin Micro-Fit Connector Pin Description for the GL61x0	38
Table 23.	Power Supply Pin Description	39
Table 24.	RS-232 Pin Description.....	39
Table 25.	USB Pin Description on Micro-fit [®] Connector	43
Table 26.	Main Receiver Parameters for the GL61x0.....	44
Table 27.	Main Transmitter Parameters for the GL61x0.....	44
Table 28.	GL61x0 Antenna Specifications	44
Table 29.	Basic AT Commands for the GL61x0	48
Table 30.	<rss> Value Description	49
Table 31.	AT+CREG Main Responses	49
Table 32.	AT+WMBS Responses	50
Table 33.	AT+WMBS Band Selection	50
Table 34.	AT+CPIN Main Responses	51
Table 35.	Main AT Commands used for the GL61x0.....	51
Table 36.	AT+CPIN Main Response	53
Table 37.	AT+WHCFN SIM Selection.....	53

Table 38.	AT+WHCNF Main Responses.....	54
Table 39.	Requirement of X-modem Downloading for GL61x0.....	55
Table 40.	No Communications with the GL6100 Through the Serial Link	56
Table 41.	No Communications with the GL6110 Through the USB	57
Table 42.	Receiving a “NO CARRIER” Message	58
Table 43.	Extended Error Codes	59
Table 44.	GL61x0 Operating Modes.....	60
Table 45.	AT+WBHV Behavior Configuration.....	61
Table 46.	Power Consumption without the Sierra Wireless Software Suite (Serial Port Auto Shutdown Mode Enabled); Typical Values	62
Table 47.	Power Consumption without the Sierra Wireless Software Suite (Serial Port Auto Shutdown Mode Disabled); Typical Values	63
Table 48.	Power Consumption without the Sierra Wireless Software Suite; Typical Values	65
Table 49.	List of Recommended Equipments.....	66
Table 50.	Operating Mode Information	67
Table 51.	Standards Conformity for the GL61x0	69
Table 52.	Applicable Standards and Requirements for the GL61x0.....	69
Table 53.	Operating Class Temperature Range.....	70
Table 54.	ISO Failure Mode Severity Classification.....	71
Table 55.	Life Stress Test.....	71
Table 56.	Environmental Resistance Stress Test.....	72
Table 57.	Corrosive Resistance Stress Test	72
Table 58.	Thermal Resistance Cycle Stress Test.....	73
Table 59.	Mechanical Resistance Stress Tests.....	73
Table 60.	Handling Resistance Stress Tests.....	75
Table 61.	Standards Conformity for the GL61x0	78
Table 62.	Applicable Standards and Requirements for the GL61x0.....	78
Table 63.	8-pin Micro-Fit Connector.....	80
Table 64.	Recommended SIM Card Socket.....	80

>> 1. Overview

The GL61x0 is a wireless modem that allows users to connect to a wireless network. It offers quad band 850/900/1800/1900 MHz GPRS Class 10 capabilities and it supports the Sierra Wireless Software Suite. The Sierra Wireless Software Suite is the world's most comprehensive cellular development environment, which allows embedded standard ANSI C applications to be natively executed directly on the Embedded Module. For more information about the Sierra Wireless Software Suite, refer to the documents listed in section 18.1 Sierra Wireless Software Documentation.

Note: This document does not cover the programmable capabilities available through the Sierra Wireless Software Suite.

1.1. Variants

The GL61x0 comes in two variants:

- the GL6100 which has an RS-232 connection, and
- the GL6110 which has a USB connection.

Note: The GL6100 may be used with either an external SIM or Embedded SIM.

1.1.1. Ordering Information

Refer to the following table for the product number marketing (PNMKT) of the GL61x0 series.

Table 1. GL61x0 Variants with Corresponding PNMKT

GL61x0 Variant	Description	PNMKT
GL6100	GL6100 – RS232 Version	GL6100
GL6100 Embedded SIM	GL6100 – RS232 Version with Embedded SIM	GL6100SM3
GL6110	GL6110 – USB Version	GL6110

1.1.2. Shipment Configuration

The GL61x0 comes in two shipment configurations. Refer to the following table for the inclusions in each shipment package.

Table 2. GL61x0 Shipment Configuration

Shipment Configuration	Notes
GL6100 + Adaptive Cable + DC Cable + Antenna	Refer to section 20.1 GL6100 2-Cable Package (antenna included) for more information.
GL6110 + USB Cable + FME Antenna	Refer to section 20.3 GL6110 Package for more information.

1.2. Overall Dimensions



Figure 1. GL61x0 Plug & Play Modem

The following table lists the GL61x0's physical characteristics.

Table 3. GL61x0 Physical Dimensions

Length	67mm
Width	51.5mm
Thickness	23.5mm
Weight	~60 g (GL61x0 only)
Volume	81.78 cm ³
Housing	Plastic

1.3. GSM/GPRS Features

- 2 Watts EGSM 900/GSM 850 radio section running with 4.75 ~ 32 Volts DC input for the GL6100; and USB Power, 5 Volts DC input for the GL6110
- 1 Watt GSM1800/1900 radio section running with 4.75 ~ 32 Volts DC input for the GL6100; and USB Power, 5 Volts DC input for the GL6110
- Hardware GPRS class 10 capable

1.4. Connectors

- One 8-pin Micro-Fit Connector
- RF Connector (FME type)

1.5. Interfaces

GL6100 – UART Version	GL6110 – USB Version
Power Supply (4.75V to 32V DC input)	Power Supply (USB Power, 5V DC input)
Serial Link (RS-232)	USB connection
3V/1V8 SIM Interface	3V/1V8 SIM Interface
LED Status Indicator	LED Status Indicator
Antenna Interface	Antenna Interface

1.6. Environmental Compliance

1.6.1. RoHS Compliance

The GL61x0 is compliant with RoHS Directive 2002/95/EC which sets limits for the use of certain restricted hazardous substances. This directive states that “from 1st July 2006, new electrical and electronic equipment put on the market does not contain lead, mercury, cadmium, hexavalent chromium, polybrominated biphenyls (PBB) or polybrominated diphenyl ethers (PBDE)”.



1.6.2. Disposing of the Product

This electronic product is subject to the EU Directive 2002/96/EC for Waste Electrical and Electronic Equipment (WEEE). As such, this product must not be disposed off at a municipal waste collection point. Please refer to local regulations for directions on how to dispose of this product in an environmental friendly manner.



2. GL61x0 Feature Set

This section enumerates the feature set available on the GL61x0.

Table 4. GL61x0 Feature Set

Features	Description		
Sierra Wireless Software Suite	Sierra Wireless Software Suite programmable: <ul style="list-style-type: none"> • Native execution of embedded standard ANSI C applications • Custom AT command creation • Custom application library creation • Standalone operation 		
Standard	<table border="0"> <tr> <td> <ul style="list-style-type: none"> • 850 MHz / 900 MHz • E-GSM compliant • Output power: class 4 (2W) • Fully compliant with ETSI GSM phase 2 + normal MS </td> <td> <ul style="list-style-type: none"> • 1800 MHz / 1900 MHz • Output power: class 1 (1W) • Fully compliant with ETSI GSM phase 2 + normal MS </td> </tr> </table>	<ul style="list-style-type: none"> • 850 MHz / 900 MHz • E-GSM compliant • Output power: class 4 (2W) • Fully compliant with ETSI GSM phase 2 + normal MS 	<ul style="list-style-type: none"> • 1800 MHz / 1900 MHz • Output power: class 1 (1W) • Fully compliant with ETSI GSM phase 2 + normal MS
<ul style="list-style-type: none"> • 850 MHz / 900 MHz • E-GSM compliant • Output power: class 4 (2W) • Fully compliant with ETSI GSM phase 2 + normal MS 	<ul style="list-style-type: none"> • 1800 MHz / 1900 MHz • Output power: class 1 (1W) • Fully compliant with ETSI GSM phase 2 + normal MS 		
GPRS	<ul style="list-style-type: none"> • Class 10 • PBCCH support • Coding schemes: CS1 to CS4 • Compliant with SMG31bis • Embedded TCP/IP stack 		
Interfaces	<ul style="list-style-type: none"> • RS-232 (V.24/V.28) Serial interface for GL6100 supporting: <ul style="list-style-type: none"> ▪ Baud rate (bits/s): 300, 600, 1200, 2400, 4800, 9600, 19200, 38400, 57600, 115200, 230400, 460800 and 921600 ▪ Autobauding (bits/s): from 1200 to 921600 • USB 2.0 interface, Full speed, 12Mbit/s for GL6110 • 1.8V/3V SIM interface • AT command set based on V.25 ter and GSM 07.05 & 07.07 • Interface for embedded application • Plug-In compatible 		
SMS	<ul style="list-style-type: none"> • Text & PDU • Point to point (MT/MO) • Cell broadcast 		
Data	<ul style="list-style-type: none"> • Data circuit asynchronous • Transparent and Non Transparent modes • Up to 14,400 bits/s • MNP Class 2 error correction • V42.bis data compression 		
GSM Supplement Services	<ul style="list-style-type: none"> • Call forwarding • Call barring • Multiparty • Call waiting and call hold • Calling line identity • Advice of charge • USSD 		

Features	Description
Others	<ul style="list-style-type: none"> • • Real Time Clock with calendar

2.1. Supported Bands

The GL61x0 supports either EU bands (EGSM900/DCS1800) or US bands (GSM850/PCS1900). Users may switch from one supported band to another using AT commands.

Refer to sections 8.4 Checking the Band Selection and 8.5 Switching Bands for more information regarding switching bands.

2.2. Protection

2.2.1. Power Supply

2.2.1.1. GL6100 – UART Version

The GL6100 is protected against voltage over +32V. When the input voltage (V_{in}) exceeds the limit, the supply voltage is disconnected to protect the internal electronic components from overvoltage.

Note: An 800mA/250V fuse is directly bonded on the Adaptive cable of GL6100. The fuse model is **FSD 800mA/250V FAST-ACTING**.



Figure 2. Adaptive Cable Fuse

2.2.1.2. GL6110 – USB Version

The GL6110 is protected against voltage over +5V. When the input voltage (V_{in}) exceeds the limit, the supply voltage is disconnected to protect the internal electronic components from overvoltage.

2.2.2. Electrostatic Discharge

The GL61x0 withstands ESD according to IEC 1000-4-2 requirements for all accessible parts, except for the RF connector which withstands ESD as follows:

- +/- 8kV of air discharge
- +/- 4kV of contact discharge

2.2.3. Main Serial Link and USB Connection

Both GL6100 and GL6110 are internally protected against electrostatic surges on its lines by ESD protection and it also has the following filtering guarantees:

- EMI/RFI protection on both input and output
- Signal smoothing

2.2.4. SIM Interfaces

The GL61x0's SIM interface is ESD protected. Transient Voltage Suppressor (TVS) diodes are internally added on the signals connected to the SIM interface in order to prevent any damage from electrostatic discharge.

3. GL61x0 Cables and Accessories

3.1. Adaptive Cable (for the GL6100)

The adaptive cable provides the serial interface and is used as the power source of the GL6100. It has three edges/plugs.

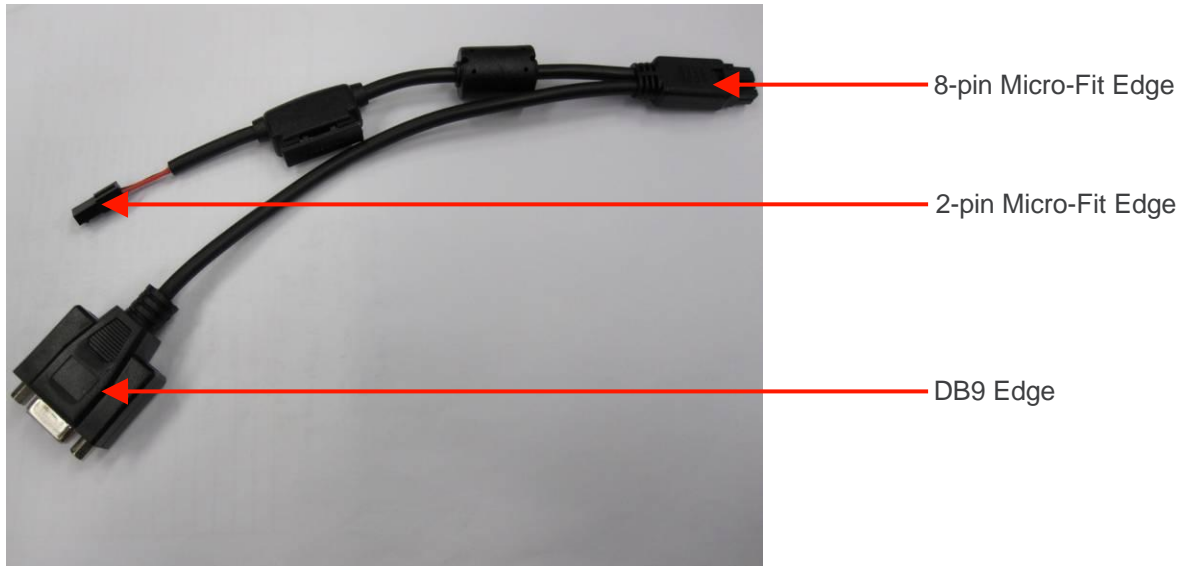

Figure 3. Adaptive Cable for the GL6100

3.1.1. 8-pin Micro-Fit Edge

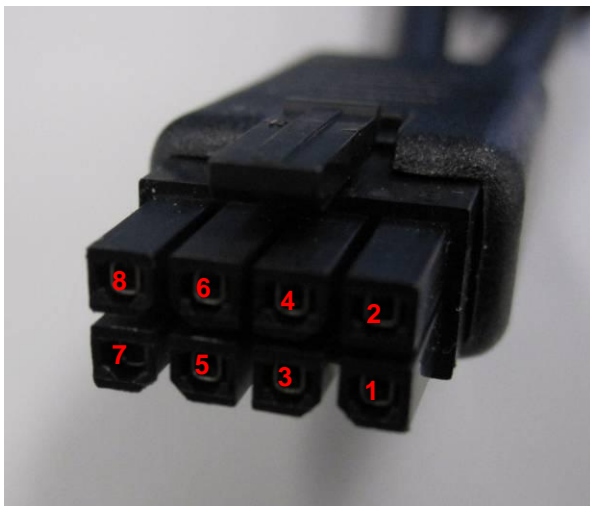

Figure 4. 8-pin Micro-Fit Edge of the Adaptive Cable

Refer to the following table for the pin description of the 8-pin Micro-Fit Edge of the Adaptive cable.

Table 5. 8-pin Micro-Fit Connector Pin Description

Pin Number	Signal	Description
1	RS232-CTS	Main RS232 Clear To Send
2	RS232- RTS	Main RS232 Request To Send
3	RS232-RXD	Main RS232 Receive Serial Data
4	RS232-TXD	Main RS232 Transmit Serial Data
5	RS232-DTR	Main RS232 Data Terminal Ready
6	GND	Ground Connection
7	Vin	Power Supply with a 4.75 ~ 32V DC input
8	Adaptive Cable Detect	Detection of the Adaptive Cable

Refer to Table 22 8-pin Micro-Fit Connector Pin Description for more information about the pin assignments and description.

3.1.2. DB9 Edge



Figure 5. DB9 Edge of the Adaptation Cable

Refer to the following table for the pin description of the DB9 Edge of the Adaptation Cable.

Table 6. DB9 Connector Pin Description

Pin Number	Signal	Description
1	Not Connected	
2	RS232 – RXD	Output Data to DTE
3	RS232 – TXD	Input Date from DTE
4	RS232 – DTR	Input Signal from DTE
5	GND	Ground Connection
6	Not Connected	
7	RS232 – RTS	Flow Control Signal from DTE
8	RS232 – CTS	Flow Control Signal to DTE
9	Not Connected	

3.1.3. 2-pin Micro-Fit Edge

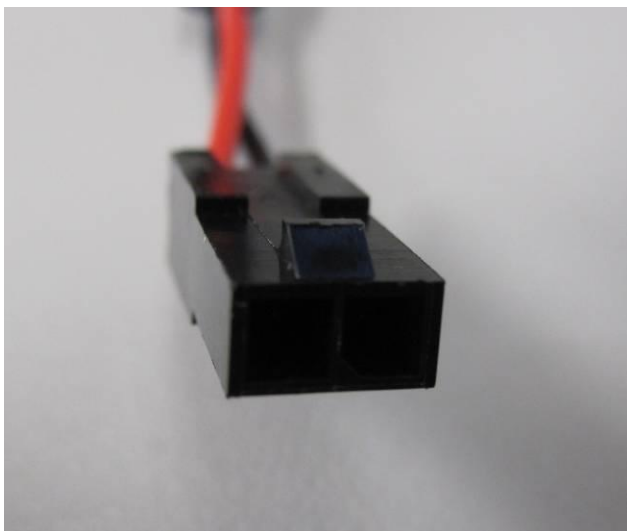

Figure 6. 2-pin Micro-Fit Edge of the Adaptive Cable

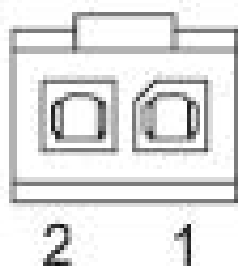

Figure 7. Pin Assignment of the 2-pin Micro-Fit Edge

Refer to the following table for the pin description of the 2-pin Micro-Fit Edge of the Adaptive cable.

Table 7. 2-pin Micro-Fit Connector Pin Description

Pin Number	Signal	Description
1	GND	Ground Connection
2	Vin	For GL6100 – 4.75V to 32V For GL6110 – 5V

3.3. DC Cable (for the GL6100)

This cable supplies the power source for the GL6100, and is used with the adaptive cable.

Refer to Table 2 GL61x0 Shipment Configuration to see which shipment configuration of the GL6100 comes with this cable.

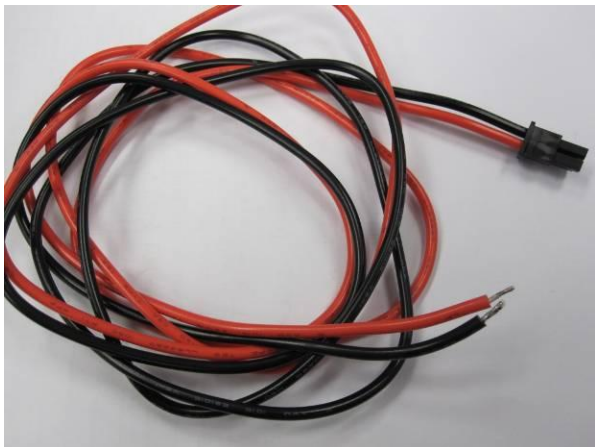

Figure 10. DC Cable

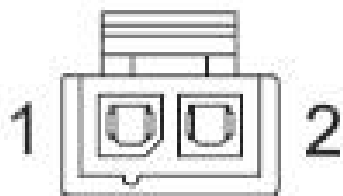

Figure 11. Pin Assignment of the DC Cable

Table 8. DC Cable Pin Description

Pin Number	Signal	Description
1	GND	
2	Vin	

3.4. AC/DC Adaptor (for the GL6100)

The AC/DC adaptor is used with the Adaptive cable. It comes with a short-circuit protection adaptor to help protect the GL61x0 from overvoltage and power surges.

Refer to Table 2 GL61x0 Shipment Configuration to see which shipment configuration of the GL6100 comes with this cable.



Figure 12. AC/DC Adaptor

3.5. Micro-fit[®] USB Cable (for the GL6110)

The USB cable provides the USB connection and is used as the power source of the GL6110.



Figure 13. Micro-fit[®] USB Cable



Figure 14. USB Connector on Micro-fit® USB Cable

Refer to the following tables for the pin description of the USB cable.

Table 9. 8-pin Micro-Fit Connector Pin Assignment

Pin Number	Signal	Description
1	D+	
2	NC	Not connected
3	D-	
4	NC	Not connected
5	NC	Not connected
6	GND	Ground
7	Vin	Power Supply with a 5V DC input
8	NC	Not connected

Table 10. USB Pin Assignment

Pin Number	Signal	Description
1	Vin	Vbus 5V output from PC
2	D-	Universal Serial Bus Data Negative
3	D+	Universal Serial Bus Data Positive
4	GND	Ground Connection

3.6. FME Antenna

Refer to Table 2 GL61x0 Shipment Configuration to see which shipment configuration of the GL61x0 comes with this antenna.



Figure 15. FME Antenna

Table 11. FME Antenna Characteristics

Antenna Frequency Range	824MHz ~ 960MHz / 1710MHz ~ 1910MHz
Impedance	50Ω Nominal
VSWR	3.5:1 Max
Gain (antenna + cable)	1.0dBi

4. Functional Specifications

This section discusses the functional specifications of the GL61x0.

4.1. Functional Architecture

The global architecture of the GL61x0 is shown in the figures below.

4.1.1. GL6100 Functional Architecture

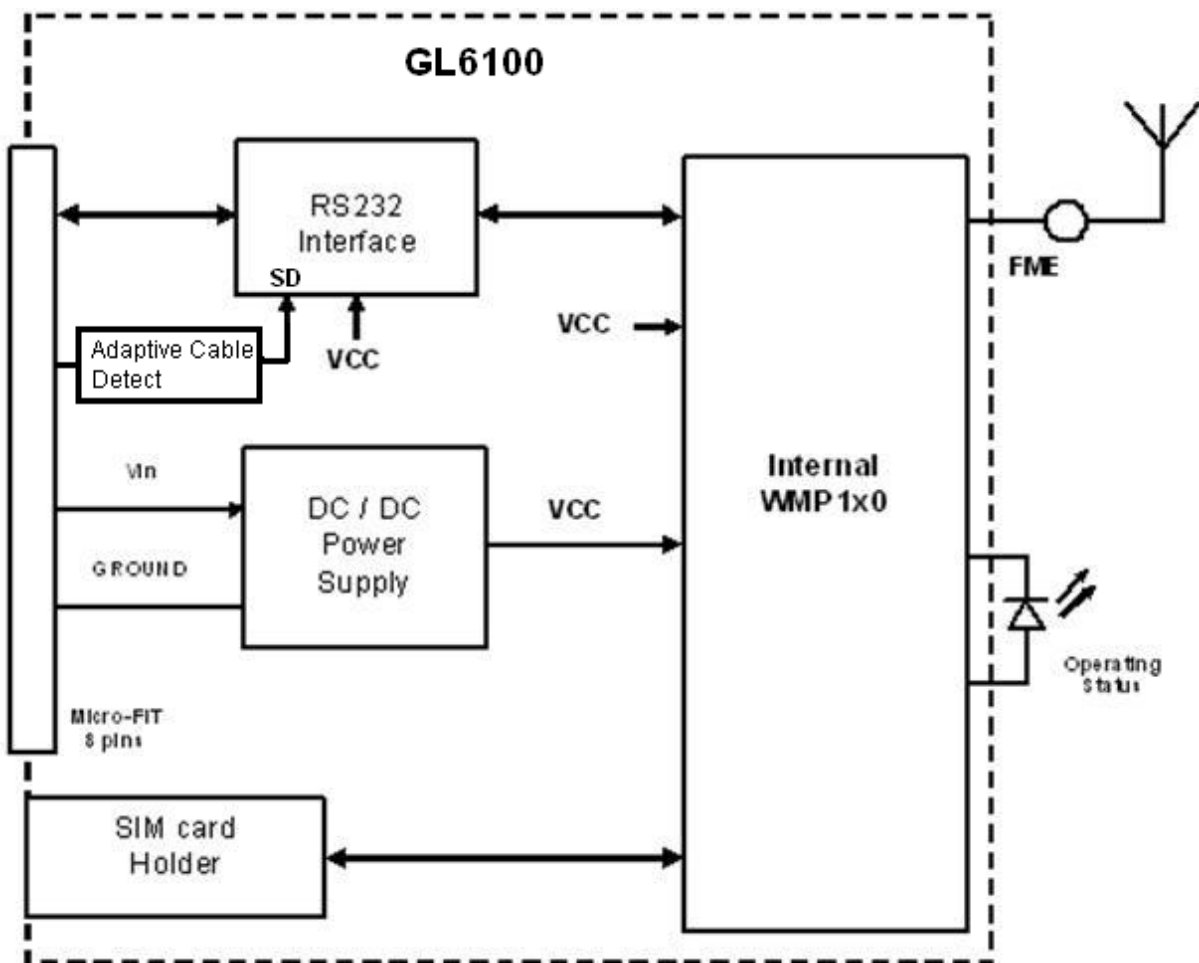

Figure 16. GL6100 Functional Architecture

4.1.2. GL6110 Functional Architecture

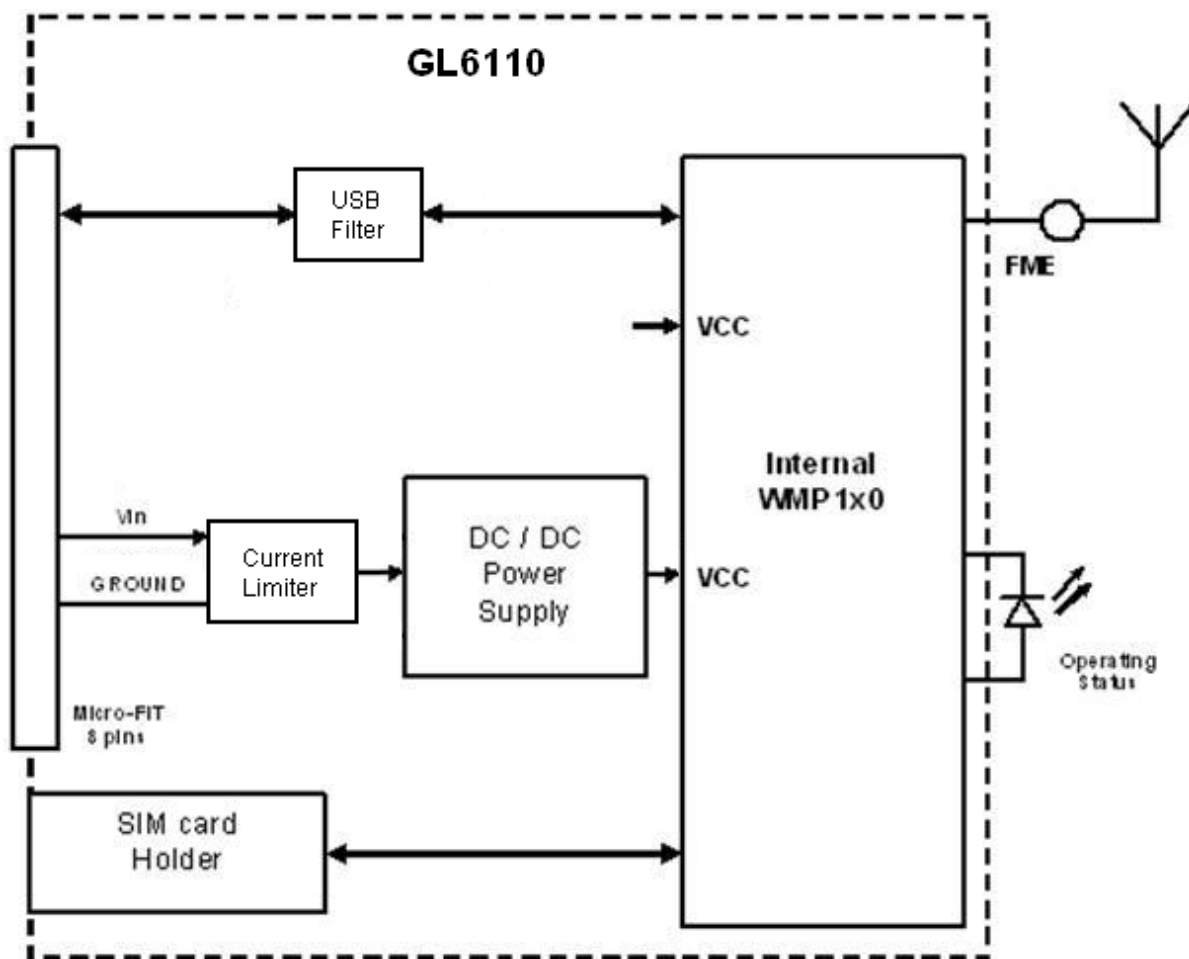

Figure 17. GL6110 Functional Architecture

4.2. RF Functionalities

The Radio Frequency (RF) component of the GL61x0 is based on a specific quad-band chip that contains the following:

- Digital low-IF receiver
- Quad-band LNA (Low Noise Amplifier)
- Offset PLL (Phase Locked Loop) transmitter
- Frequency synthesizer
- Digitally controlled crystal oscillator (DCXO)
- Tx / Rx FEM (Front-End Module) for quad-band GSM/GPRS

The Radio Frequency (RF) range complies with Phase II EGSM 900/DCS 1800 and GSM 850/PCS 1900 recommendations. The corresponding frequency recommendations for both transmission and reception bands are listed in the table below.

Table 12. Supported RF Frequencies

	Transmit Band (Tx)	Receive Band (Rx)
GSM 850	824 to 849 MHz	869 to 894 MHz
E-GSM 900	880 to 915 MHz	925 to 960 MHz
DCS 1800	1710 to 1785 MHz	1805 to 1880 MHz
PCS 1900	1850 to 1910 MHz	1930 to 1990 MHz

4.3. Operating System

The GL61x0 is Sierra Wireless Software Suite compliant. With Sierra Wireless Software Suite, customers can embed their own applications with the GL61x0 and turn it into a solution for their specific market need. The operating system of the GL61x0 is also responsible for the following functions:

- AT command processing
- Real Time Clock (RTC) with calendar
- Full GSM or GSM/GPRS Operating System stack

>> 5. Technical Specifications

5.1. Power Supply

The GL6100 is supplied by an external DC voltage (V_{in}) that has a varied range and the GL6110 is supplied by the USB Power, 5V DC.

The main regulation is made with an internal DC/DC converter in order to supply all the internal functions with a DC voltage.

Refer to the following table for the GL61x0's operating voltage range and maximum current.

Table 13. Power Supply Electrical Characteristics

GL61x0 Variant	Operating Voltage Range	Maximum Current
GL6100	4.75V to 32V DC, nominal at 12V	2.0A Peak at 4.75V
GL6110	As USB specify from 4.75V to 5.25V, nominal at 5V	Limited Up to 500mA

5.1.1. GL6100 – UART Version

For the GL6100, V_{in} ranges from +4.75V to +32V at 2.2A.

Refer to the following table for the consequences of supplying the GL6100 with too much or too little voltage. Note that the correct operation of the GL6100 in connected mode is not guaranteed if the input voltage falls below 4.75V.

Table 14. Effects of Power Supply Defect for the GL6100

If the voltage	Then
Falls below 4.75V	GSM communication is not guaranteed.
Is over 32V (transient peaks)	The GL6100's protection is guaranteed by internal settings.
Is over 32V (continuous over voltage)	The GL6100's protection is done by the fuse* (the supply voltage is disconnected).

* The fuse is an 800mA/250V FAST-ACTING 5*20mm. The embedded fuse in the Adaptive Cable of the GL6100 is the **FSD 800mA/250V FAST-ACTING**.

Caution: *The minimum input voltage specified here is the GL6100 input. Be mindful of the input voltage decrease caused by the power cable. When using the cable that comes with the GL6100 packages, this input drop is at around 800mV at 4.75V and 220mV at 32V.*

The power supply must withstand a current peak of 2.8A in 4.75V input voltage. Refer to the Power Consumption Tables in section 12 Power Consumption for more current information.

5.1.2. GL6110 – USB Version

For the GL6110, Vin is 5V.

Refer to the following table for the consequences of supplying the GL6110 with too much or too little voltage. Note that the correct operation of the GL6110 in connected mode is not guaranteed if the input voltage falls below 4.75V.

Table 15. Effects of Power Supply Defect for the GL6100

If the voltage	Then
Falls below 4.75V	GSM communication is not guaranteed.
Is over 5V (transient peaks)	The GL6110's protection is guaranteed by internal settings.
Is over 5V (continuous over voltage)	The GL6110's protection is done by internal Transil Diode (the supply voltage is disconnected).

5.2. Mechanical Specifications

5.2.1. Mechanical Drawing

The following diagram describes the mechanical specification of the GL61x0.

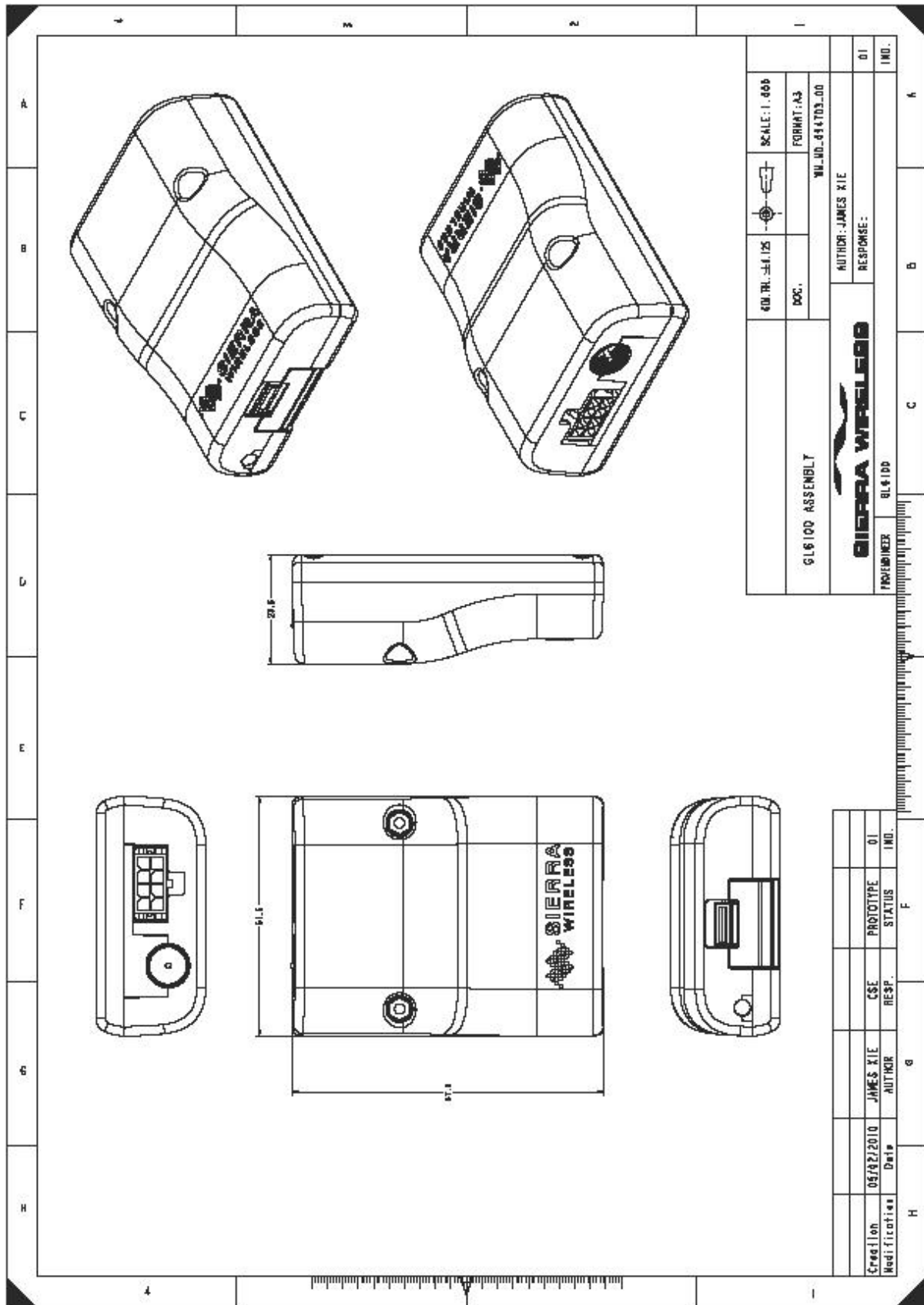

Figure 18. GL61x0 Mechanical Drawing

5.2.2. Mechanical Constraints

5.2.2.1. Micro-Fit Connector

The following table lists the mechanical constraints that must be taken into account when using the 8-pin Micro-Fit connector.

Table 16. Micro-Fit Connector Mechanical Constraints

Description	Mechanical Limit	Notes
Connector Mate and Unmate Forces	MINIMUM withdrawal force: 3.7N (0.8lbf)	This is the least amount of force needed to unplug the cable from the 8-pin Micro-Fit connector.
	MAXIMUM insertion force: 8.0N (1.8lbf)	This is the maximum amount of force that should be used when inserting a male connector into the 8-pin Micro-Fit connector. Using force greater than this might damage the Micro-Fit connector.
Terminal Retention Force (in housing)	MINIMUM retention force: 24.5N (5.5lbf)	This is the least amount of force needed to keep the power supply cable connected to the 8-pin Micro-Fit connector.
Terminal Insertion Force (into housing)	MAXIMUM insertion force: 14.7N (3.3lbf)	This is the maximum amount of force that should be used when pushing in the power supply cable into the 8-pin Micro-Fit connector. Using force greater than this might damage the Micro-Fit connector.

5.2.2.2. FME Connector

The following table lists the mechanical constraints that must be taken into account when using the FME RF connector.

Table 17. FME RF Connector Mechanical Constraints

Mating Force	M8XP .75 thd.
---------------------	---------------



6. Interfaces and Peripherals

This section describes the different connectors, interfaces and peripherals that connect with the GL61x0.

The GL61x0 comes with the following interfaces:

- SIM Interface
- LED Status Indicator
- 8-pin Micro-Fit Connector (this interface provides the connection for the following)
 - Power Supply
 - Main Serial Link (RS-232) for the GL6100 or USB connection for the GL6110
- RF Interface

6.1. Front Interface

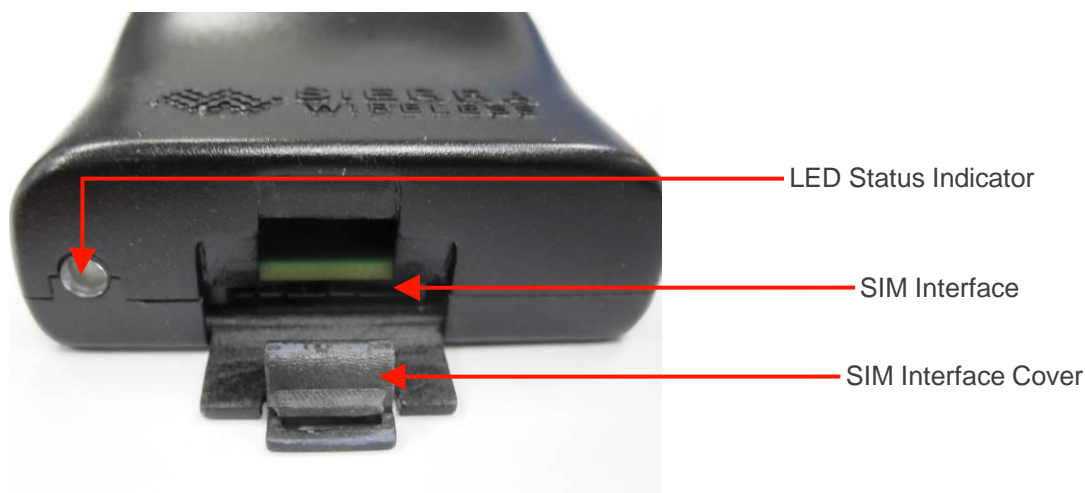

Figure 19. GL61x0 Front Interface

6.1.1. SIM Interface

This interface controls both 1.8V and 3V SIM cards and it is fully compliant with GSM 11.11 recommendations concerning SIM functions. Subscriber Identification Module (SIM) cards can be directly connected to the GL61x0 through the embedded SIM socket.

The GL61x0's SIM interface is ESD protected. Transient Voltage Suppressor (TVS) diodes are internally added on the signals connected to the SIM interface in order to prevent any damage from electrostatic discharge.

The SIM uses five (5) SIM signals, namely:

- SIM-VCC, is the SIM power supply
- SIM-RST, is reset
- SIM-CLK, is clock
- SIM-IO, is the I/O port
- SIMPRES, is for detecting if a SIM card has been inserted or not

Refer to the following table for the electrical characteristics of the SIM interface.

Table 18. SIM Interface Electrical Characteristics

Parameter	Conditions	Minimum	Typ	Maximum	Unit
SIM-IO V _{IH}	I _{IH} = ± 20µA	0.7xSIM-VCC			V
SIM-IO V _{IL}	I _{IL} = 1mA			0.4	V
SIM-RST, SIM-CLK V _{OH}	Source current = 20µA	0.9xSIM-VCC			V
SIM-IO V _{OH}	Source current = 20µA	0.8xSIM-VCC			
SIM-RST, SIM-IO, SIM- CLK V _{OL}	Sink current = -200µA			0.4	V
SIM-VCC Output Voltage	SIM-VCC = 2.9V I _{IN} = 1mA	2.84	2.9	2.96	V
	SIM-VCC = 1.8V I _{IN} = 1mA	1.74	1.8	1.86	V
SIM-VCC current	Supply to the Embedded Module = 3.6V			10	mA
SIM-CLK Rise/Fall Time	Loaded with 30pF		25		ns
SIM-RST, Rise/Fall Time	Loaded with 30pF		25		ns
SIM-IO Rise/Fall Time	Loaded with 30pF		0.7	1	µs
SIM-CLK Frequency	Loaded with 30pF			3.25	MHz
SIMPRES V _{IL}		-0.5	0	0.54	V
SIMPRES V _{IH}		1.33	1.8	2.2	V

Note: A LOW to HIGH transition of SIMPRES means that the SIM card is inserted and a HIGH to LOW transition means that the SIM card was removed.

6.1.1.1. SIM Socket Pin Description

Refer to the following table for the pin description of the SIM socket.

Table 19. SIM Interface Pin Description

Pin #	Signal	I/O	I/O Type	Reset State	Description
1	SIM-VCC	O	2V9 / 1V8	-	SIM Power Supply
2	SIM-RST	O	2V9 / 1V8	0	SIM Reset
3	SIM-CLK	O	2V9 / 1V8	0	SIM Clock
7	SIM-IO	I/O	2V9 / 1V8	Pull up*	SIM Data
8	SIMPRES	I	1V8	Pull-down	SIM Card Detect

* SIM-IO pull-up is about 10KΩ

6.1.2. LED Status Indicator

The GL61x0 has a red LED that indicates the current operational status of the device.

Table 20. GL61x0 LED Status

GL61x0 State	LED Status	Description
ON	Permanently lighted	The GL61x0 is powered ON, but not registered in the network.
	Slow flash (LED is switched ON for 200ms, OFF for 2s)	The GL61x0 is powered ON, and registered in the network.
	Quick flash (LED is switched ON for 200ms, OFF for 600ms)	The GL61x0 is powered ON, registered on the network, and communication is in progress.
	Very quick flash (LED is switched ON for 100ms, OFF for 200ms)	The GL61x0 is powered ON, but the software downloaded is either corrupted or non-compatible ("BAD SOFTWARE").
OFF	OFF	The GL61x0 is either switched OFF, or the Flash LED has been disabled by the user*.

* The Flash LED can be disabled by the user when in Sleep Mode in order to save power consumption. Refer to section 10.1 Enabling/Disabling the Flash LED and document [7] Firmware 7.42 AT Commands Manual (Sierra Wireless Software Suite 2.32) for more information on how to disable the Flash LED using an AT command.

The LED state is set to HIGH during RESET time and undefined during software initialization time.

During software initialization time, and for a maximum of 2 seconds after RESET cancellation, the LED signal of the GL61x0 is toggling and will not provide any indication of the GL61x0's status. After the software initialization time or the 2 seconds after RESET cancellation, the LED will resume to displaying the true status of the GL61x0.

The following diagram shows the LED state during reset and GL61x0 initialization.

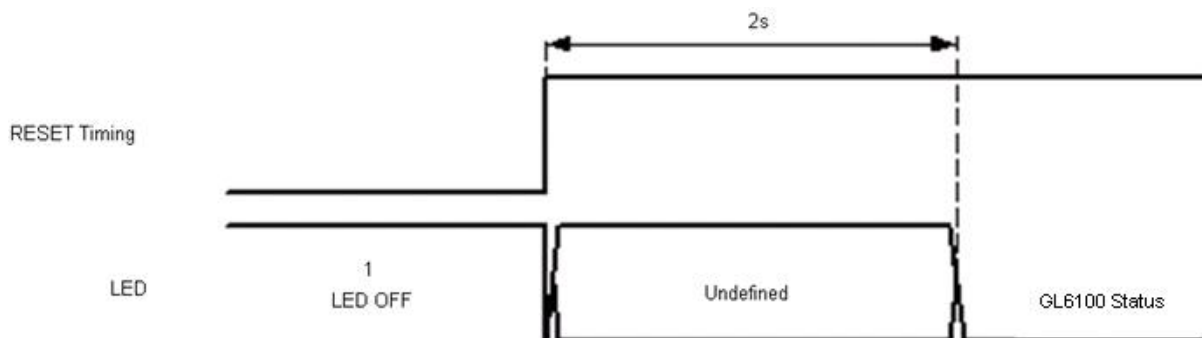

Figure 20. LED State During Reset and Initialization Time

6.2. Back Interface



Figure 21. GL61x0 Back Interface

6.2.1. 8-pin Micro-Fit Connector

The 8-pin Micro-Fit connector is used for the following connections:

Table 21. 8-pin Micro-Fit Connections

GL6100 – UART Version	GL6110 – USB Version
External DC power supply connection with voltage from +4.75V to +32V	External DC power supply connection with voltage 5V
Main serial link (RS-232)	USB connection

Caution: *Bear in mind that the cables plugged into the 8-pin Micro-Fit connector should always be compatible with the GL61x0 variant. Interchanging the cables between the two GL61x0 variants (that is, using the RS-232 cable on the GL6110 or using the Micro-fit[®] USB cable on the GL6100) may damage either the modem or the PC.*

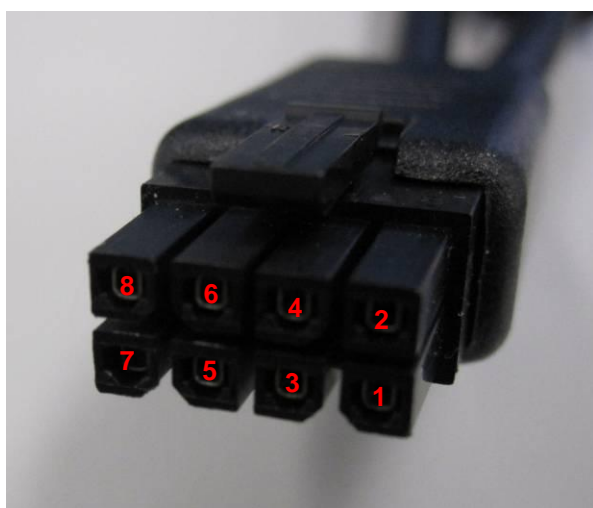

Figure 22. 8-pin Micro-Fit Connector on Cable Side

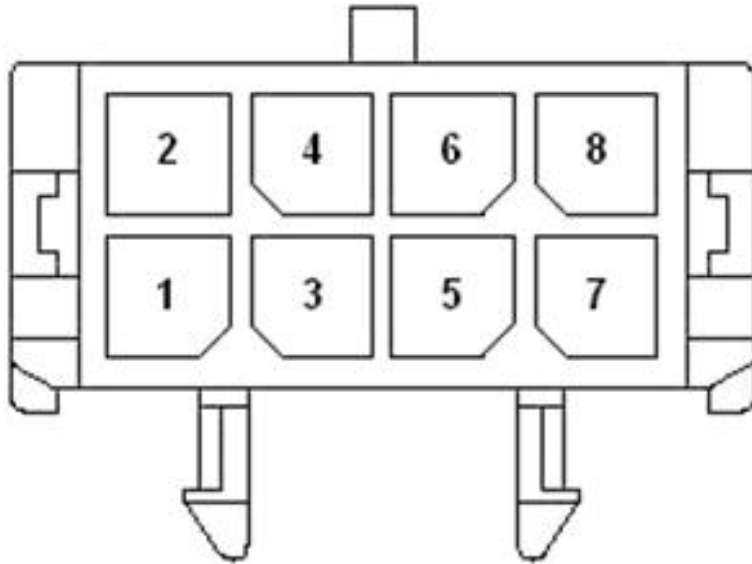

Figure 23. Pin Assignment of the 8-pin Micro-Fit Connector on GL61x0

Refer to the following tables for the pin description of the 8-pin Micro-Fit connector depending on the GL61x0 variant.

Table 22. 8-pin Micro-Fit Connector Pin Description for the GL61x0

Pin #	GL6100					GL6110				
	Signal	I/O*	I/O Type	Description	Reset State	Signal	I/O*	I/O Type	Description	Reset State
1	RS232-CTS	O	+/-5V5	Main RS232 Clear To Send	Z	D+			Universal Serial Bus Data Positive	
2	RS232- RTS	I	RS-232	Main RS232 Request To Send	Z	NC			Not connected	
3	RS232-RXD	O	+/-5V5	Main RS232 Receive Serial Data	1	D-			Universal Serial Bus Data Negative	
4	RS232-TXD	I	RS-232	Main RS232 Transmit Serial Data	Z	NC			Not connected	
5	RS232-DTR	I	RS-232	Main RS232 Data Terminal Ready	Z	NC			Not connected	
6	GND		Power Supply	Ground Connection		GND	Power Supply		Ground Connection	
7	Vin	I	Power Supply	Power Supply with 4.75 ~ 32V DC input		Vin	Power Supply		Power Supply with 5V DC input	
8	Adaptive Cable Detect	I	Hi-Z / GND	Connected to pin 6 (GND) by the Adaptive Cable	Z	NC			Not connected	

* The I/O direction only concerns the nominal signal.

Caution: Pins 1, 2, 3, 4, 5 and 8 are used by either the RS-232 serial link interface or the USB connection. It is strictly prohibited to connect these pins to any power supply as there is a risk of damaging the GL61x0.

6.2.1.1. Power Supply Connection

The DC input interface is available from the 8-pin Micro-Fit connector. The input voltage range (Vin) varies depending on the GL61x0 variant.

For the GL6100, Vin is from 4.75V to 32V, with a typical operating voltage of 12V.

For the GL6110, Vin is 5V.

Table 23. Power Supply Pin Description

Pin #	Signal	Description
6	GND	Ground
7	Vin	4.75V to 32V DC input for the GL6100, 5V for the GL6110

6.2.1.2. Setup Communications with the GL6100: Main Serial Link Connection (RS-232)

For the GL6100, the main serial link, RS-232, performs the voltage level adaptation (V24/CMOS) between the internal GL6100 (DCE) and external applications (DTE).

The signals available on the RS-232 serial link are as follows:

- TX data (RS232-TXD)
- RX data (RS232-RXD)
- Request To Send (RS232-RTS)
- Clear To Send (RS232-CTS)
- Data Terminal Ready (RS232-DTR)

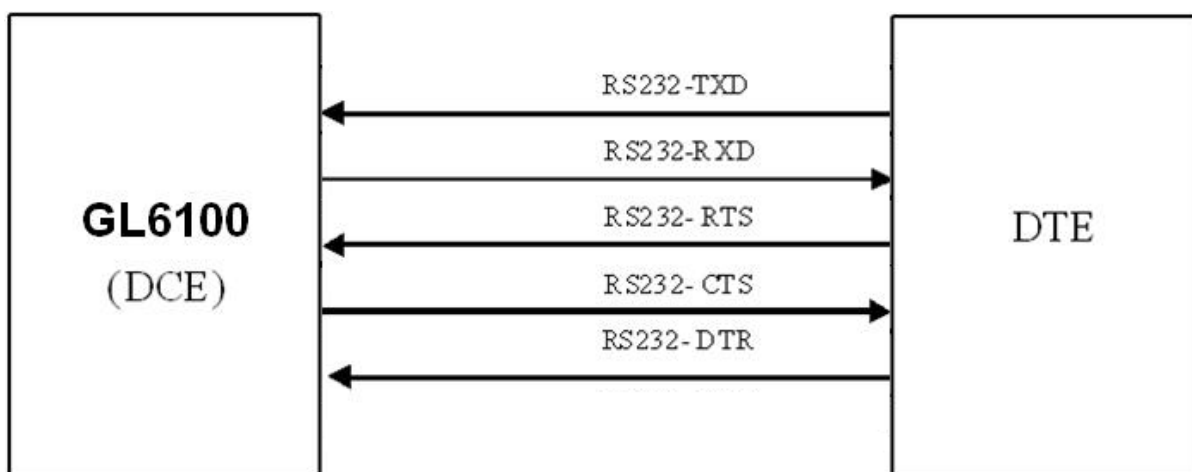

Figure 24. RS-232 Serial Link Signals

Refer to the following table for the RS-232 serial link pin description.

Table 24. RS-232 Pin Description

Pin #	Signal*	I/O**	Reset State	Description
1	RS232-CTS	O	Z	Clear To Send
2	RS232-RTS	I	Z	Request To Send
3	RS232-RXD	O	1	Receive serial data

Pin #	Signal*	I/O**	Reset State	Description
4	RS232-TXD	I	Z	Transmit serial data
5	RS232-DTR	I	Z	Data Terminal Ready

* According to the PC (DTE) view.

** According to the GL6100 (DCE) view, from which the direction of the signal is defined.

The RS-232 interface has been designed to allow flexibility in the use of the serial interface signals. Note that the use of TX and RX signals are mandatory; while the use of CTS, RTS and DTR signals are recommended.

Tip: *The GL6100 is designed to operate using all serial interface signals and it is recommended to use RS232-RTS and RS232-CTS for hardware flow control in order to avoid data corruption during transmission. Otherwise proper configurations of the pins are required.*

The GL6100 also implements the Serial Port Auto Shut Down feature with the DTR signal. It is recommended to use the RS232-DTR signal to benefit from the current consumption improvement performed by this feature.

6.2.1.2.1. RS-232 Implementation

The following subsections describe how the RS-232 serial link can be implemented to suit different designs.

6.2.1.2.1.1. 5-wire Serial Interface RS-232 Implementation

The signals used in this implementation are as follows:

- RS232-TXD
- RS232-RXD
- RS232-CTS
- RS232-RTS
- RS232-DTR

Note: *The RS232-DTR signal must be managed following the V24 protocol signaling if the Sleep Idle Mode and Serial Port Auto Shut Down feature are to be used.*

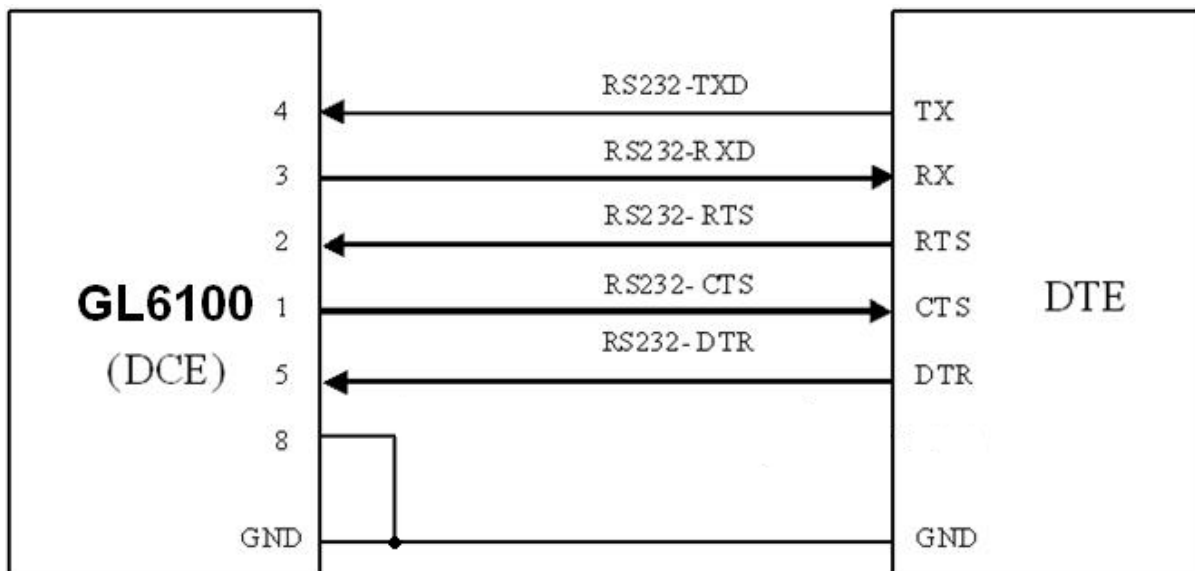

Figure 25. Serial Link Implementation for a 5-wire UART

6.2.1.2.1.2. 4-wire Serial Interface RS-232 Implementation

The signals used in this implementation are as follows:

- RS232-TXD
- RS232-RXD
- RS232-CTS
- RS232-RTS

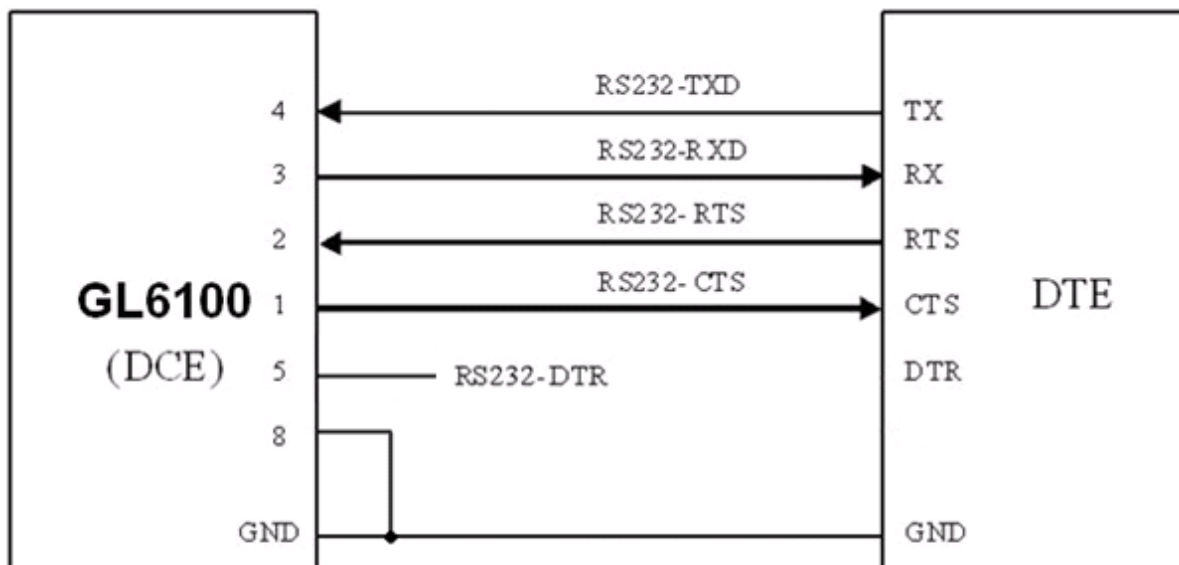

Figure 26. Serial Link Implementation for a 4-wire UART

6.2.1.2.1.3. 2-wire Serial Interface RS-232 Implementation

The signals used in this implementation are as follows:

- RS232-TXD
- RS232-RXD

Note: Although this case is possible, it is not recommended.

The flow control mechanism must be managed from the customer end.

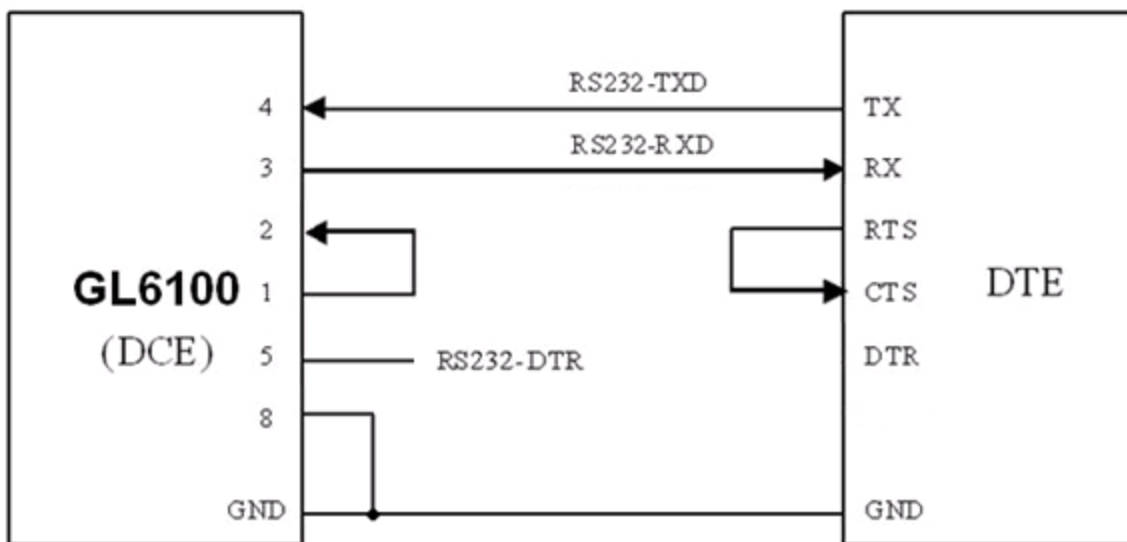

Figure 27. Serial Link Implementation for a 2-wire UART

The RS232-CTS and RS232-RTS signals are not used in this configuration. Configure the AT command **AT+IFC=0,0** to disable the flow control function of the modem. Refer to document [7] Firmware 7.42 AT Commands Manual (Sierra Wireless Software Suite 2.32) for more information regarding AT commands.

6.2.1.2.2. Autobauding Mode

The autobauding mode allows the GL6100 to detect the baud rate used by the DTE connected to the RS-232 serial link. The autobauding mode is controlled by AT commands. Refer to document [7] Firmware 7.42 AT Commands Manual (Sierra Wireless Software Suite 2.32) for more information.

6.2.1.2.3. Serial Port Auto Shut Down Feature

The RS-232 serial link can be shut down when there is no activity between the DTE and the GL6100. This can help improve the power consumption performance.

The Serial Port Auto Shut Down feature is controlled by the AT command **AT+WASR**. Enter:

- **AT+WASR=1,1,"GPIO19",10** to enter the serial port auto shut down mode
- **AT+WASR=0,1** to exit the serial port auto shut down mode

The RS-232 interface Auto Shutdown mode will immediately activate/deactivate after the AT command set. To wake the GL6100 up from the Auto Shutdown mode, use the external trigger on the DTR (set the signal from LOW to HIGH).

Refer to document [7] Firmware 7.42 AT Commands Manual (Sierra Wireless Software Suite 2.32) for more information on the **AT+WASR** command.

Caution: *GPIO19 is reserved for serial port auto shut down feature. It is prohibited for customer use. Improper access to GPIO19 by customers may lead to unexpected behavior on serial port performance.*

It is prohibited to use the serial port auto shut down feature when the RS232-DTR is not used in the application. Otherwise, there will be data lost from the DTE side to the GL6100.

6.2.1.3. Setup Communications with the GL6110: USB Connection

The GL6110 has an embedded full speed USB 2.0 interface at 12Mbit/s. It could direct connect to the PC USB port with the Micro-fit[®] to USB type A Cable.

The signals on the Micro-fit[®] USB cable are as follows:

- Vin, 5V (pin 1)
- D- (pin 2)
- D+ (pin 3)
- GND (pin 4)



Figure 28. USB Signals on the USB Type A Connector

Refer to the following table for the USB pin description on the Micro-fit[®] connector.

Table 25. USB Pin Description on Micro-fit[®] Connector

Pin #	Signal	Description
1	D+	Universal Serial Bus Data Positive
3	D-	Universal Serial Bus Data Negative

6.2.1.3.1. USB Driver

The USB Driver is available at <http://www.sierrawireless.com/>.

6.2.2. RF Interface

The GL61x0's antenna connector allows the transmission of radio frequency (RF) signals from the device to an external antenna. This interface is an FME type connector and its nominal impedance is 50Ω.

6.2.2.1. RF Performances

RF performances are compliant with ETSI recommendation GSM 05.05. Refer to Table 12 Supported RF Frequencies for the list of supported RF frequencies. Refer to the tables below for the main parameters used for both the Receiver and the Transmitter.

Table 26. Main Receiver Parameters for the GL61x0

Parameters	Values
GSM850 Reference Sensitivity	-108dBm Static
E-GSM900 Reference Sensitivity	-108dBm Static
DCS1800 Reference Sensitivity	-107dBm Static
PCS1900 Reference Sensitivity	-107dBm Static
Selectivity @ 200 kHz	> +9dBc
Selectivity @ 400 kHz	> +41dBc
Linear dynamic range	63dB
Co-channel rejection	>= 9dBc

Table 27. Main Transmitter Parameters for the GL61x0

Parameters	Values
Maximum output power (EGSM & GSM850)	33dBm +/- 2dB at ambient temperature
Maximum output power (GSM1800 & PCS1900)	30dBm +/- 2dB at ambient temperature
Minimum output power (EGSM & GSM850)	5dBm +/- 5dB at ambient temperature
Minimum output power (GSM1800 & PCS1900)	5dBm +/- 5dB at ambient temperature

6.2.2.2. Antenna Specifications

For any other antenna applied, it must fulfill the requirements specified in the table below.

The optimum operating frequency depends on the application. A dual-band or quad-band antenna should operate in these frequency bands and have the following characteristics:

Table 28. GL61x0 Antenna Specifications

Characteristics	E-GSM 900	DCS 1800	GSM 850	PCS 1900
TX Frequency	880 to 915 MHz	1710 to 1785 MHz	824 to 849 MHz	1850 to 1910 MHz
RX Frequency	925 to 960 MHz	1805 to 1880 MHz	869 to 894 MHz	1930 to 1990 MHz
Impedance	50Ω			
VSWR	Rx max	1.5 :1		
	Tx max	1.5 :1		
Typical Radiated gain	0dBi in one direction at least			

Tip: *Both mechanical and electrical antenna adaptations are key issues in the design of a GSM terminal. Sierra Wireless strongly recommends working with an antenna manufacturer to either develop an antenna adapted to the application or to adapt an existing solution to the application.*

>> 7. Using the GL61x0

7.1. Getting Started

To setup the GL61x0, follow the procedures shown below.

1. Insert the SIM card into the SIM card socket. (Refer to 7.1.1 Inserting the SIM Card and 7.1.2 Extracting the SIM Card for more details on how to insert and extract the SIM card from the GL61x0.)



2. Connect the antenna to the RF connector.



3. Plug the I/O and power cable into the GL61x0 and switch on the external power supply source.

Note: Make sure to plug in a cable that is compatible with the GL61x0 variant (that is, use the adaptive cable for the GL6100, and use the Micro-fit[®] USB cable for the GL6110) to avoid damaging the GL61x0 or the PC.



Refer to section 8.7 Main AT Commands for the GL6100 for the list of main AT commands used to configure the GL61x0.

Note: For automotive applications, it is recommended to connect the Vin line of the GL61x0 directly to the positive terminal of the battery. Refer to section 14 Recommendations When Using the GL61x0 on Trucks for more information on using the GL61x0 in automotive applications.

7.1.1. Inserting the SIM Card

In order to insert the SIM card into the GL61x0, follow the procedure shown below.

1. Prepare the SIM card in the correct position as shown in the figure.



2. Slide the SIM card into the SIM holder.



3. Use a tool to help push the SIM card into the SIM holder. Push the SIM card all the way in until you hear a clicking sound.



4. Close the SIM holder.



7.1.2. Extracting the SIM Card

In order to extract the SIM card from the GL61x0, follow the procedure shown below.

1. Open the SIM socket flap.
2. Use a tool to further push the SIM card into the SIM holder. Push until you hear a clicking sound.



3. The SIM card should spring out a little bit after the clicking sound.



4. Extract the SIM card from the GL61x0.



7.2. Operational Status

The GL61x0's operational status is defined by a red LED, which is located next to the SIM connector on the GL61x0 panel. Refer to section 6.1.2 LED Status Indicator for more information about the GL61x0's LED status indicator.



8. Communicating with the GL61x0

After setting up the GL61x0, communications can be established by directly sending AT commands to the device using terminal software such as HyperTerminal for MS Windows. The following sub-sections describe how this is done.

8.1. Communications Testing for the GL61x0

To perform a communications test after the GL61x0 has been setup, do the following:

- Connect the RS-232 link between the external application (DTE) and the GL6100 (DCE).
- Or connect the GL61x0 with the USB interface. The COM Port number could be checked under the Device Manager. (Refer to section 6.2.1.3 Setup Communications with the GL6110: USB Connection)
- Configure the RS-232 port of the DTE as follows:
 - Bits per second: 115, 200bps
 - Data bits: 8
 - Parity: None
 - Stop bits: 1
 - Flow control: hardware
- Using a communication software such as HyperTerminal, enter:
AT↵
- When communications have been established, the GL6100 will respond with an “OK”, which is displayed in the HyperTerminal window.

If communications cannot be established with the GL6100, do the following:

- Check the RS-232 connection between the application (DTE) and the GL6100 (DCE).
- Check the configuration of the COM port used on the DTE.

Refer to the table below for other AT commands that can be used after getting the GL61x0 started.

Table 29. Basic AT Commands for the GL61x0

AT Command	Description
AT+CGMI	To check if the serial link is OK. The GL6100 will respond with "WAVECOM MODEM" when it is OK.
AT+CPIN=xxxx	To enter a PIN code, xxxx (if activated).
AT+CSQ	To verify the received signal strength.
AT+CREG?	To verify the registration of the GL6100 on the network.
ATD<phone number>	To initiate a voice call.
ATH	To hang up (end of call).

For further information about these AT commands and their associated parameters, refer to document [7] Firmware 7.42 AT Commands Manual (Sierra Wireless Software Suite 2.32).

8.2. Verifying the Received Signal Strength

The GL61x0 only establishes a call if the received signal strength is strong enough. Using communication software such as HyperTerminal, enter **AT+CSQ** to check the received signal strength. The response returned will follow the format **+CSQ: <rss>, <ber>**

where: <rss> = received signal strength indication, and <ber> = channel bit error rate.

Refer to the table below for the description of the <rss> values returned.

Table 30. <rss> Value Description

<rss> Value	Description
0 – 10	Received signal strength is insufficient.
11 – 31	Received signal strength is sufficient.
32 – 98	Not defined.
99	No measure available.

Refer to document [7] Firmware 7.42 AT Commands Manual (Sierra Wireless Software Suite 2.32) for more information regarding the **AT+CSQ** AT Command.

8.3. Verifying the Network Registration

To check the network registration, make sure that a valid SIM card has been properly inserted into the GL61x0.

Note: When using the GL6100 with Embedded SIM, ensure that the device has been registered by the network provider.

Using a communication software such as HyperTerminal, enter **AT+CREG?** to verify the network registration of the GL61x0. Refer to the table below for the list of main responses returned.

Table 31. AT+CREG Main Responses

AT+CREG Response	Description
+CREG: 0,0	Not registered.
+CREG: 0,1	Registered on the home network.
+CREG: 0,5	Registered on a roaming network.

If the GL61x0 is not registered on the network, do the following:

- Check the connection between the GL61x0 and the antenna.
- Verify the signal strength to determine the received signal strength (refer to section 8.2 Verifying the Received Signal Strength).

Refer to document [7] Firmware 7.42 AT Commands Manual (Sierra Wireless Software Suite 2.32) for more information regarding the **AT+CREG** AT Command, and other AT commands relating to network registration in GPRS mode.

8.4. Checking the Band Selection

Using a communication software such as HyperTerminal, enter **AT+WMBS?** to check the band selection of the GL61x0. Refer to the table below for the list of main responses returned.

Table 32. AT+WMBS Responses

AT+WMBS Response	Description
+WMBS: 0,x	Mono band mode 850MHz is selected
+WMBS: 1,x	Mono band mode extended 900MHz is selected
+WMBS: 2,x	Mono band mode 1800MHz is selected
+WMBS: 3,x	Mono band mode 1900MHz is selected
+WMBS: 4,x	Dual band mode 850/1900MHz are selected
+WMBS: 5,x	Dual band mode extended 900MHz/1800MHz are selected
+WMBS: 6,x	Dual band mode extended 900MHz/1900MHz are selected

Where:

When x = 0, the band has not been modified since the last boot of the GL61x0;

When x = 1, the band has been modified since the last boot of the GL61x0, and will have to be reset in order to take the previous modification(s) into account.

Refer to document [7] Firmware 7.42 AT Commands Manual (Sierra Wireless Software Suite 2.32) for more information regarding the **AT+WMBS** AT Command.

8.5. Switching Bands

Using a communication software such as HyperTerminal, enter **AT+WMBS** to change the band settings of the GL61x0 and switch between EU (EGSM900/DCS1800) and US (GSM850/ PCS1900) bands and vice versa. Refer to the following table for the list of **AT+WMBS** parameters that can be used and their corresponding description.

Table 33. AT+WMBS Band Selection

AT+WMBS Command	Description
AT+WMBS=0,x	Switch to mono band mode 850MHz.
AT+WMBS=1,x	Switch to mono band mode extended 900MHz.
AT+WMBS=2,x	Switch to mono band mode 1800MHz.
AT+WMBS=3,x	Switch to mono band mode 1900MHz.
AT+WMBS=4,x	Switch to dual band mode 850/1900MHz.
AT+WMBS=5,x	Switch to dual band mode extended 900MHz/1800MHz.
AT+WMBS=6,x	Switch to dual band mode extended 900MHz/1900MHz.

Where:

When x = 0, the GL61x0 will have to be reset to start on the specified band(s);

When x = 1, the band switch is effective immediately. However, this mode is forbidden while in Connected mode and during the GL61x0's initialization.

Refer to document [7] Firmware 7.42 AT Commands Manual (Sierra Wireless Software Suite 2.32) for more information regarding the **AT+WMBS** AT Command.

8.6. Checking the PIN Code Status

Using a communication software such as HyperTerminal, enter **AT+CPIN?** to check the PIN code status. Refer to the table below for the list of main responses returned.

Table 34. AT+CPIN Main Responses

AT+CPIN Response	Description
+CPIN: READY	The PIN code has been entered.
+CPIN: SIM PIN	The PIN code has not been entered.

Refer to document [7] Firmware 7.42 AT Commands Manual (Sierra Wireless Software Suite 2.32) for more information regarding the **AT+CPIN** AT Command.

8.7. Main AT Commands for the GL6100

The table below lists the main AT Commands required for starting the GL61x0. For other available AT Commands, refer to document [7] Firmware 7.42 AT Commands Manual (Sierra Wireless Software Suite 2.32).

Table 35. Main AT Commands used for the GL61x0

Feature/Function	AT Command	Response	Description
Check network registration	AT+CREG?	+CREG: 0,1	The GL61x0 is registered on the network.
		+CREG: 0,2	The GL61x0 is not registered on the network; registration attempt is ongoing.
		+CREG: 0,0	The GL61x0 is not registered on the network; no registration attempt has been made.
Enter PIN code	AT+CPIN=xxxx (xxxx = PIN code)	OK	PIN code accepted.
		+CME ERROR: 16	Incorrect PIN code (with +CMEE = 1 mode*).
		+CME ERROR: 3	PIN code already entered (with +CMEE = 1 mode*).
Check the selected band	AT+WMBS?	+WMBS: <Band>,<ResetFlag> OK	The currently selected band mode is returned.
Switch bands	AT+WMBS=<Band>	OK	Band switch is accepted; the GL61x0 has to be reset for the change to be effective.

Feature/Function	AT Command	Response	Description
	AT+WMBS=<Band>,0	OK	Band switch is accepted; the GL61x0 has to be reset for the change to be effective.
	AT+WMBS=<Band>,1	OK	Band switch is accepted and the GSMS stack has been restarted.
	AT+WMBS=<Band>	+CME ERROR: 3	Band selected is not allowed.
Receive a call	ATA	OK	Answer the call.
Initiate a call	ATD<phone number>; (Do not forget the « ; » at the end for « voice » call)	OK	Communication established.
		+CME ERROR: 11	PIN code not entered (with +CMEE = 1 mode).
		+CME ERROR: 3	AOC credit exceeded or communications has already been established.
Initiate an emergency call	ATD112; (Do not forget the « ; » at the end for « voice » call)	OK	Communications established.
Hang up	ATH	OK	
Communication has been lost		NO CARRIER	
Store the parameters in EEPROM	AT&W	OK	The configuration settings are stored in EEPROM (non-volatile memory).

* The command AT+CMEE=1 switches to a mode that enables a more complete error diagnostic.

8.8. Echo Function

If no echo is displayed when entering an AT command, it could mean either of the following:

- The “local echo” parameter of your communication software such as HyperTerminal is disabled.
- The GL61x0 echo function is disabled.

To enable the GL61x0 echo function, enter the AT command **ATE1**.

When sending AT commands to the GL61x0 using a communication software such as HyperTerminal, it is recommended to:

- Disable the “local echo” parameter of your communication software
- Enable the GL61x0 echo function (use the **ATE1** AT command)

In a machine-to-machine communication with the GL61x0, it is recommended to disable the GL61x0’s echo function (using the **ATE0** AT command) in order to avoid useless CPU processing.

Refer to document [7] Firmware 7.42 AT Commands Manual (Sierra Wireless Software Suite 2.32) for more information about the **ATE0** and **ATE1** AT Commands.



9. Using the GL6110 with Embedded SIM

The GL6100 may be used with either Embedded SIM or an external SIM. This section discusses the different maintenance options available when using the GL6100 with Embedded SIM.

9.1. Operation

Using a communication software such as HyperTerminal, enter **AT+CPIN?** to check if Embedded SIM is working. Refer to the table below for the list of main response returned.

Table 36. AT+CPIN Main Response

AT+CPIN Response	Description
+CPIN: READY	Embedded SIM is working

If you can't access the network, Embedded SIM might not be activated on the operator's network.

9.2. Switching Between Embedded SIM and an External SIM

Using a communication software such as HyperTerminal, enter **AT+WHCNF** to switch between using Embedded SIM or an external SIM. Refer to the following table for the list of **AT+WHCNF** parameters that can be used and their corresponding description.

Table 37. AT+WHCNF SIM Selection

AT+WMBS Command	Description
AT+WHCNF=4,0	To specify that an external SIM is preferred.
AT+WHCNF=4,1	To specify that only the external SIM will be used.
AT+WHCNF=4,2	To specify that only Embedded SIM will be used

Note: The GL6100 must be rebooted after the switch state update before changes are applied.

9.3. Software Configuration

To check whether the correct SIM interface has been selected, use a communication software such as HyperTerminal and enter **AT+WHCNF?** to check the SIM configuration. Refer to the table below for the list of main responses returned.

Table 38. AT+WHCNF Main Responses

Status	Description
+WHCNF: 4,0,0	External SIM privileged (default)
+WHCNF: 4,1,0	External SIM only
+WHCNF: 4,2,0	Internal SIM only

The GL6100 must be rebooted after the switch state update to apply changes made.

Note: Only use Sierra Wireless Software Suite 2.3x for the inSIM3 model.

>> 10. GL61x0 Maintenance

10.1. Enabling/Disabling the Flash LED

The GL61x0 has a red LED indicator that shows the status of the GSM network. It is possible to disable this LED during Sleep mode in order to reduce power consumption. Using a communication software such as HyperTerminal, enter:

- **AT+WHCNF=1,0** to deactivate Flash LED
- **AT+WHCNF=1,1** to activate Flash LED

Note: The GL61x0 will need to be restarted for the new settings to take effect. Refer to document [7] Firmware 7.42 AT Commands Manual (Sierra Wireless Software Suite 2.32) for more information about enabling/disabling Flash LED.

10.2. Resetting the GL61x0

Resetting the GL61x0 could be triggered by the AT command **AT+CFUN=1**, or:

- For GL6100 – RS232, it could be done by unplugging and then re-plugging the power supply (Vin).
- For GL6110 – USB, disconnect the Modem from the PC USB port.

Caution: While the GL6110 is being reset by AT command, the PC communication software might have to close the USB port and then re-open it to resume communications.

10.3. Operating System Upgrade Procedure

The GL61x0 operating system is stored in flash memory and can be easily upgraded.

The operating system file can be downloaded into the modem using the X-modem protocol. The **AT+WDWL** command allows the download process to be launched.

Refer to the following table for the list of GL61x0 signals required to proceed with X-modem downloading.

Table 39. Requirement of X-modem Downloading for GL61x0

GL61x0 Variants	Requirement
GL6100 – RS232	RS232 – TXD, RS232 – RXD, RS232 – CTS, RS232 – RTS
GL6110 – USB	USB Connection to PC, and firmware version after Sierra Wireless Software Suite 2.31

The operating system file can also be downloaded into the modem using the DOTA (download over the air) feature. This feature is available with the Sierra Wireless Software Suite interface.

Refer to document [7] Firmware 7.42 AT Commands Manual (Sierra Wireless Software Suite 2.32) for more information regarding this procedure.

11. Troubleshooting the GL61x0

This section of the document describes possible problems that might be encountered when using the GL61x0 and their corresponding solutions. To read about other troubleshooting information, refer to the FAQs (Frequently Asked Questions) page at <http://www.sierrawireless.com>.

Caution: *Again, make sure to only use a cable that is compatible with the GL61x0 variant (that is, use the adaptive cable for the GL6100, and use the Micro-fit[®] USB cable for the GL6110) to avoid damaging either the GL61x0 or the PC.*

11.1. GL6100 – RS232 Version

11.1.1. No Communications with the GL6100 through the Serial Link

If the GL6100 does not answer to AT commands through the serial link, refer to the table below for possible causes and their corresponding solutions.

Table 40. No Communications with the GL6100 Through the Serial Link

If the GL6100 returns	Then ask	Action
Nothing	Is the GL6100 powered correctly?	Make sure that the external power supply is connected to the GL6100 and provides a voltage within the range of 4.75V to 32V.
	Is the serial cable connected at both sides?	Check the serial cable connection.
	Does the serial cable correctly follow the pin assignments? Refer to section 6.2.1 8-pin Micro-Fit Connector for more information on the serial cable pin assignments.	Connect the cable by following the pin assignments as given in Table 22 8-pin Micro-Fit Connector Pin Description.
Nothing or non significant characters	Is the communication program properly configured on the PC?	<p>Ensure that the settings of the communication program are compatible with the settings of the GL6100.</p> <p>The GL6100 factory settings are:</p> <ul style="list-style-type: none"> • Data bits = 8 • Parity = none • Stop bits = 1 • Baud rate = 115200 bps • Flow control = hardware
	Is there another program interfering with the communication program (i.e. conflict on communication port access)?	Close the interfering program.

11.2. GL6110 – USB Version

11.2.1. No Communications with the GL6110 through the USB

If the GL6110 does not answer to AT commands through the USB, refer to the table below for possible causes and their corresponding solutions.

Table 41. No Communications with the GL6110 Through the USB

If the GL6110 returns	Then ask	Action
Nothing	Is the GL6110 powered correctly?	Make sure that the GL6110 is recognized by the PC and the USB port provides a voltage of 5V.
	Is the USB Device Driver correctly installed?	Refer to section 6.2.1.3 Setup Communications with the GL6110: USB Connection.
	Is the USB cable connected at both sides?	Check the USB connection.
	Does the USB cable correctly follow the pin assignments? Refer to section 6.2.1 8-pin Micro-Fit Connector for more information on the serial cable pin assignments.	Connect the cable by following the pin assignments as given in Table 22 8-pin Micro-Fit Connector Pin Description.
Nothing or non significant characters	Is the communication program properly configured on the PC?	<p>Ensure that the settings of the communication program are compatible with the settings of the GL6110.</p> <p>The GL6110 factory settings are:</p> <ul style="list-style-type: none"> • Data bits = 8 • Parity = none • Stop bits = 1 • Baud rate = 115200 bps • Flow control = hardware
	Is there another program interfering with the communication program (i.e. conflict on communication port access)?	Close the interfering program.

11.3. Receiving “ERROR”

The GL61x0 returns an “ERROR” message (in reply to an AT command) in the following cases:

- The AT command syntax is incorrect. In this case, check the command syntax (refer to document [7] Firmware 7.42 AT Commands Manual (Sierra Wireless Software Suite 2.32) for more information).
- The AT command syntax is correct, but was transmitted using the wrong parameters.

Enable the verbose error report method to see the error codes associated with the command syntax.

- Enter the **AT+CMEE=1** command in order to change the error report method to the verbose method, which includes the error codes.
- Re-enter the AT command which previously caused the reception of an “ERROR” message in order to get the Mobile Equipment error code.

When the verbose error report method is enabled, the response of the GL61x0 in case of error is either:

- +CME ERROR: <error result code>
or
- +CMS ERROR: <error result code>

Refer to document [7] Firmware 7.42 AT Commands Manual (Sierra Wireless Software Suite 2.32) for more information on the error result code description and further details on the **AT +CMEE** command.

Note: It is strongly recommended to always enable the verbose error report method to get the Mobile Equipment error code (enter the **AT +CMEE=1** command).

11.4. Receiving “NO CARRIER”

If the GL61x0 returns a “NO CARRIER” message upon an attempted call (voice or data), refer to the following table for possible causes and their corresponding solutions.

Table 42. Receiving a “NO CARRIER” Message

If the GL61x0 returns	Then ask	Action
“NO CARRIER”	Is the received signal strong enough?	Refer to section 8.2 Verifying the Received Signal Strength for more information on how to verify the strength of the received signal.
	Is the GL61x0 registered on the network?	Refer to section 8.3 Verifying the Network Registration for more information on how to verify the network registration.
	Is the antenna properly connected?	Refer to section 6.2.2.2 Antenna Specifications for more information on the antenna requirements of the GL61x0.
	Is the band selection correct?	Refer to section 8.5 Switching Bands for more information on how to switch bands.
“NO CARRIER” (when trying to issue a voice communication)	Is the semicolon (;) entered immediately after the phone number in the AT command?	Ensure that the semicolon (;) is entered immediately after the phone number in the AT command. e.g. ATD#####;
“NO CARRIER” (when trying to issue a data communication)	Is the SIM card configured for data/fax calls?	Configure the SIM card for data/fax calls. (Ask your network provider if necessary).
	Is the selected bearer type supported by the called party?	Ensure that the selected bearer type is supported by the called party.
	Is the selected bearer type supported by the network?	Ensure that the selected bearer type is supported by the network. If still unsuccessful, try selecting the bearer type using the AT command: AT+CBST=0,0,3

If the GL61x0 returns a “NO CARRIER” message, you may retrieve the extended error code by using the AT command **AT+CEER**. Refer to the table below for the interpretation of the extended error codes.

Table 43. Extended Error Codes

Error Code	Diagnosis	Hint
1	Unallocated phone number	
16	Normal call clearing	
17	User busy	
18	No user responding	
19	User alerting, no answer	
21	Call rejected	
22	Number changed	
31	Normal, unspecified	
50	Requested facility not subscribed	Check your subscription. (Is data subscription available?)
68	ACM equal or greater than ACMmax	The credit of your pre-paid SIM card has expired.
252	Call barring on outgoing calls	
253	Call barring on incoming calls	
3, 6, 8, 29, 34, 38, 41, 42, 43, 44, 47, 49, 57, 58, 63, 65, 69, 70, 79, 254	Network causes	Refer to document [7] Firmware 7.42 AT Commands Manual (Sierra Wireless Software Suite 2.32) for further details or call your network provider.

For all other codes and their corresponding details, refer to the documents in section 18.2 Firmware Documentation.

12. Power Consumption

The following sub-sections detail out the power consumption values of the GL61x0 for various modes, RF bands and type of software (with and without a Sierra Wireless Software Suite application). These consumption values were obtained by performing measurements on GL61x0 samples at a temperature of 25°C with the assumption of a 50Ω RF output and a 3V SIM card.

12.1. Various Operating Modes

The power consumption levels of the GL61x0 vary depending on the operating mode used. Refer to the table below for the different kinds of operating modes available.

Table 44. GL61x0 Operating Modes

Operating Mode	Description
OFF Mode	Not Supported. When Vin power is supplied to the GL61x0, it will be automatically be powered ON.
Alarm Mode	Not Supported. The ON/OFF switch is always HIGH.
Active Idle Mode	Default mode for the GL61x0. This is when the RF function is active and the GL61x0 is synchronized with the network, but there are currently no communications. There are no functional restrictions in this mode.
Sleep Idle Mode (only available on GL6100)	When the GL6100 has a location update with a live network but with no GSM/GPRS connection, while the UART interface is NOT available.
Active Mode	GSM/GPRS features are NOT available and the embedded application is running while the UART remains active.
Sleep Mode (only available on GL6100)	GSM/GPRS features as well as the UART interface are NOT available.
Connected Mode	When the GL61x0 is supporting a GSM voice codec connection with a live network with DTMF support.
Transfer Mode	When the GL61x0 has a GPRS data transfer connection with a live network.
Serial Port Auto Shutdown Mode (only available on GL6100)	When the GL6100 has an embedded UART transceiver; it could be automatically shut down while it is idle. The auto shutdown feature could be enabled by AT command. Refer to section 6.2.1.2.3 Serial Port Auto Shut Down Feature for more information on this feature.
Activated/Deactivated FLASH LED	The GL61x0 Flash LED can be activated or deactivated by AT command. Refer to section 10.1 Enabling/Disabling the Flash LED for more information on this feature.

12.1.1. Entering Sleep Idle Mode (only available on GL6100)

There are two different methods to enter Sleep Idle mode using the **AT+W32K** AT command. The differences between the two methods are described below:

12.1.1.1. Using AT+W32K = 1

Entering Sleep Idle mode is controlled by both the level of the DTR signal and the firmware.

The GL6100 will enter Sleep Idle mode when the DTR (viewed from the GL6100 perspective) is of LOW voltage level. To wake the GL6100 up, it is necessary to toggle the DTR from a LOW voltage level to a HIGH voltage level.

Note: The GL6100 will never enter Sleep Idle mode for as long as the DTR (viewed from the module side) is of HIGH voltage level.

This method should be applied if the application needs to forbid entering Sleep Idle mode.

12.1.1.2. Using AT+W32K = 1,0

With this option, entering Sleep Idle mode is only controlled by the firmware.

When the GL6100 has had no activities for a certain time, it will enter Sleep Idle mode automatically, regardless of the DTR level.

For more information regarding the **AT+W32K** AT command, refer to document [7] Firmware 7.42 AT Commands Manual (Sierra Wireless Software Suite 2.32).

12.1.2. Entering Active/Sleep Mode

The GL6100 could be configured to enter Active/Sleep mode using the **AT+WBHV** AT command. Refer to the following table for the list of **AT+WBHV** parameters that can be used and their corresponding description.

Table 45. AT+WBHV Behavior Configuration

AT+WBHV Command	Description
AT+WBHV=1,1	To enter Active mode.
AT+WBHV=1,2	To enter Sleep mode.
AT+WBHV=1,0	To disable Active/Sleep mode.

Note: The GL6100 must be restarted for the new behavior to be taken into account.

For more information about the **AT+WBHV** AT command, refer to document [7] Firmware 7.42 AT Commands Manual (Sierra Wireless Software Suite 2.32).

12.2. GL6100 Embedded SIM Power Consumption

Three DC inputs (V_{in}) were used to measure the consumption: $V_{inMIN}(4.75V)$, $V_{inTYP}(12V)$ and $V_{inMAX}(32V)$. Both the average current and maximum current peaks were measured. For more information on the consumption measurement procedure, refer to section 12.4 Consumption Measurement Procedure.

Note that power consumption performance is software related. The results listed in the following sub-sections were based on **Firmware 7.44**. Refer to section 10.3 Operating System Upgrade Procedure for more information on upgrading the software.

12.2.1. Power Consumption without the Sierra Wireless Software Suite

Note: TX = the current peak is the RF transmission burst (Tx burst)
RX = the current peak is the RF reception burst (Rx burst)

Table 46. Power Consumption without the Sierra Wireless Software Suite (Serial Port Auto Shutdown Mode Enabled); Typical Values

Working Modes	Parameters		Embedded SIM/ External SIM	$I_{average}$			I_{peak}	Unit
				$V_{in} = 32V$	$V_{in} = 12V$	$V_{in} = 4.75V$		
Active Idle Mode	Paging 9 (Rx burst occurrence ~2s)	External SIM	6.2	12.4	22.2	145	mA	
		Embedded SIM	6.2	12.7	22.2	147		
	Paging 2 (Rx burst occurrence ~0,5s)	External SIM	6.5	13.1	23.5	134	mA	
		Embedded SIM	6.5	13.2	24.2	148		
Sleep Idle Mode	Paging 9 (Rx burst occurrence ~2s)	External SIM	2.8	3.3	5.2	149	mA	
		Embedded SIM	2.7	4.1	6.6	148		
	Paging 2 (Rx burst occurrence ~0,5s)	External SIM	3.4	5	8.7	147	mA	
		Embedded SIM	3.6	5.8	10.1	148		
Active Mode		External SIM	6.3	12.7	22.5	36.4	mA	
		Embedded SIM	6.2	12.5	22.1	36.8		
Sleep Mode		External SIM	2.3	2.5	3.3	16.2	mA	
		Embedded SIM	2.3	2.5	3.1	17.2		
Connected Mode	850/900 MHz	PCL5 (TX power 33dBm)	External SIM	44.6	105.3	249.2	1499	mA
			Embedded SIM	44.8	105.9	250.6	1519	
		PCL19 (TX power 5dBm)	External SIM	20.6	43.7	93.2	237	mA
			Embedded SIM	20.6	44.4	95.3	237	
	1800/1900 MHz	PCL0 (TX power 30dBm)	External SIM	31.8	72.3	166.5	1003	mA
			Embedded SIM	31.7	72.3	166	1028	
PCL15 (TX power 0dBm)	External SIM	19.7	42	89.2	205	mA		
	Embedded SIM	19.7	42	89.1	207			
Transfer	850/900	Gamma 3 (TX)	External SIM	42.7	100.9	238.3	1490	mA

Working Modes	Parameters		Embedded SIM/ External SIM	I _{average}			I _{peak}	Unit
				Vin = 32V	Vin = 12V	Vin = 4.75V		
Mode class 8 (4Rx/1Tx)	MHz	power 33dBm)	Embedded SIM	42.6	101.2	238.7	1515	mA
		Gamma 17 (TX power 5dBm)	External SIM	19.6	41.5	88.2	224	
			Embedded SIM	19.5	41.9	88.8	222	
	1800/1900 MHz	Gamma 3 (TX power 30dBm)	External SIM	30.4	69.3	159	978	mA
			Embedded SIM	30.4	69.3	158.6	1005	
		Gamma 18 (TX power 0dBm)	External SIM	18.8	40.1	84.7	192	mA
	Embedded SIM	18.8	40.1	84.7	191			
Transfer Mode class 10 (3Rx/2Tx)	850/900 MHz	Gamma 3 (TX power 33dBm)	External SIM	72.5	175.2	422.7	1585	mA
			Embedded SIM	72.5	175.6	423.3	1594	
		Gamma 17 (TX power 5dBm)	External SIM	25.4	54.5	118.8	239	mA
			Embedded SIM	25.4	54.9	119.7	237	
	1800/1900 MHz	Gamma 3 (TX power 30dBm)	External SIM	47.7	110.9	262.9	1003	mA
			Embedded SIM	47.7	110.8	262	1027	
		Gamma 18 (TX power 0dBm)	External SIM	24.2	51.7	112	205	mA
			Embedded SIM	24.1	51.7	111.9	207	

Table 47. Power Consumption without the Sierra Wireless Software Suite (Serial Port Auto Shutdown Mode Disabled); Typical Values

Working Modes	Parameters		Embedded SIM/ External SIM	I _{average}			I _{peak}	Unit
				Vin = 32V	Vin = 12V	Vin = 4.75V		
Active Idle Mode	Paging 9 (Rx burst occurrence ~2s)	External SIM	8	16.7	30.1	151	mA	
		Embedded SIM	8	16.9	30.8	166		
	Paging 2 (Rx burst occurrence ~0,5s)	External SIM	8.2	17.1	31.6	158	mA	
		Embedded SIM	8.3	17.5	32.4	166		
Sleep Idle Mode	Paging 9 (Rx burst occurrence ~2s)	External SIM	4.6	8	14.2	158	mA	
		Embedded SIM	4.8	8.8	16.3	163		
	Paging 2 (Rx burst occurrence ~0,5s)	External SIM	5.3	9.6	17.4	157	mA	
		Embedded SIM	5.5	10.6	19.3	163		
Active Mode			External SIM	8	16.9	30.8	53	mA
			Embedded SIM	8	16.7	30.4	53	
Sleep Mode			External SIM	4.1	7	12.3	15	mA
			Embedded SIM	4.1	7	12.3	15	
Connected Mode	850/900 MHz	PCL5 (TX power 33dBm)	External SIM	44.6	105.3	249.2	1499	mA
			Embedded SIM	44.8	105.9	250.6	1519	
	PCL19 (TX power 5dBm)	External SIM	20.6	43.7	93.2	237	mA	
		Embedded SIM	20.6	44.4	95.3	237		

Working Modes	Parameters		Embedded SIM/ External SIM	I _{average}			I _{peak}	Unit	
				V _{in} = 32V	V _{in} = 12V	V _{in} = 4.75V			
	1800/1900 MHz	PCL0 (TX power 30dBm)	External SIM	31.8	72.3	166.5	1003	mA	
			Embedded SIM	31.7	72.3	166	1028		
		PCL15 (TX power 0dBm)	External SIM	19.7	42	89.2	205	mA	
			Embedded SIM	19.7	42	89.1	207		
Transfer Mode class 8 (4Rx/1Tx)	850/900 MHz	Gamma 3 (TX power 33dBm)	External SIM	42.7	100.9	238.3	1490	mA	
			Embedded SIM	42.6	101.2	238.7	1515		
			Gamma 17 (TX power 5dBm)	External SIM	19.6	41.5	88.2	224	mA
				Embedded SIM	19.5	41.9	88.8	222	
	1800/1900 MHz	Gamma 3 (TX power 30dBm)	External SIM	30.4	69.3	159	978	mA	
			Embedded SIM	30.4	69.3	158.6	1005		
			Gamma 18 (TX power 0dBm)	External SIM	18.8	40.1	84.7	192	mA
				Embedded SIM	18.8	40.1	84.7	191	
Transfer Mode class 10 (3Rx/2Tx)	850/900 MHz	Gamma 3 (TX power 33dBm)	External SIM	72.5	175.2	422.7	1585	mA	
			Embedded SIM	72.5	175.6	423.3	1594		
			Gamma 17 (TX power 5dBm)	External SIM	25.4	54.5	118.8	239	mA
				Embedded SIM	25.4	54.9	119.7	237	
	1800/1900 MHz	Gamma 3 (TX power 30dBm)	External SIM	47.7	110.9	262.9	1003	mA	
			Embedded SIM	47.7	110.8	262	1027		
			Gamma 18 (TX power 0dBm)	External SIM	24.2	51.7	112	205	mA
				Embedded SIM	24.1	51.7	111.9	207	

12.3. GL6110 Power Consumption

Only one DC input (V_{in}) was used to measure the GL6110 power consumption. For more information on the consumption measurement procedure, refer to section 12.4 Consumption Measurement Procedure.

Note that power consumption performance is software related. The results listed in the following subsections were based on **Firmware 7.4a**. Refer to section 10.3 Operating System Upgrade Procedure for more information on upgrading the software.

12.3.1. Power Consumption without the Sierra Wireless Software Suite

Note: TX = the current peak is the RF transmission burst (Tx burst)
RX = the current peak is the RF reception burst (Rx burst)

Table 48. Power Consumption without the Sierra Wireless Software Suite; Typical Values

Working Modes	Parameters		I _{average} Vin = 5V	I _{Peak}	Unit
Active Idle Mode	Paging 9 (Rx burst occurrence ~2s)		59.259	144.876	mA
	Paging 2 (Rx burst occurrence ~0,5s)		59.992	146.254	mA
Active Mode			63.449	71.443	mA
Connected Mode	850/900 MHz	PCL5 (TX power 33dBm)	242.351	465.515	mA
		PCL19 (TX power 5dBm)	106.619	202.616	mA
	1800/1900 MHz	PCL0 (TX power 30dBm)	157.194	446.294	mA
		PCL15 (TX power 0dBm)	81.591	162.252	mA
Transfer Mode class 8 (4Rx/1Tx)	850/900 MHz	Gamma 3 (TX power 33dBm)	252.735	465.301	mA
		Gamma 17 (TX power 5dBm)	102.5	198.985	mA
	1800/1900 MHz	Gamma 3 (TX power 30dBm)	172.435	446.294	mA
		Gamma 18 (TX power 0dBm)	99.24	175.493	mA
Transfer Mode class 10 (3Rx/2Tx)	850/900 MHz	Gamma 3 (TX power 33dBm)	453.834	462.525	mA
		Gamma 17 (TX power 5dBm)	132.548	223.545	mA
	1800/1900 MHz	Gamma 3 (TX power 30dBm)	277.077	448.643	mA
		Gamma 18 (TX power 0dBm)	126.106	193.432	mA

12.4. Consumption Measurement Procedure

This chapter describes the procedure for consumption measurement which is used to obtain the GL61x0 consumption specifications.

The GL61x0 consumption specification values are measured for all operating modes available. For more information about switching between the operating modes, refer to the appendix of document [7] Firmware 7.42 AT Commands Manual (Sierra Wireless Software Suite 2.32).

Consumption results are highly dependent on the hardware configuration used during measurement and the following sub-sections describe both the hardware and software configuration settings that should be used to obtain optimum consumption measurements.

12.4.1. Hardware Configuration

The following hardware configuration includes both the measurement equipment and the GL61x0.

12.4.1.1. Equipment

Three devices are used to perform consumption measurement:

- A communication tester
- A current measuring power supply
- A computer, to control the GL61x0 and to save measurement data

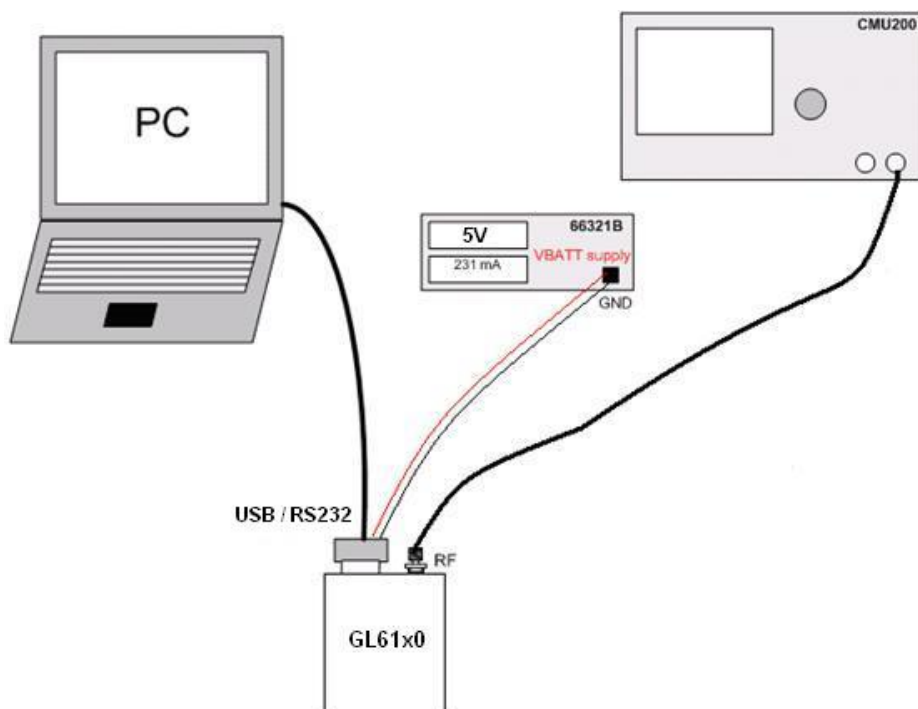

Figure 29. Typical Hardware Configuration for Power Consumption Measurement

The communication tester is a **CMU 200** from **Rhode & Schwartz**. This tester offers all required GSM/GPRS network configurations and allows a wide range of network configurations to be set.

The **66321B** power supply is used to supply the GL61x0, and it could also be used to measure the total current drain by the device. The current measurement data is read through the GPIB connection.

Note that a SIM card must be inserted during all consumption measurements.

The following table lists the recommended equipments to use for the consumption measurement.

Table 49. List of Recommended Equipments

Device	Manufacturer	Part Number	Notes/Description
Communication Tester	Rhode & Schwartz	CMU 200	Quad Band GSM/DCS/GPRS
Current measuring power supply	Agilent	66321B	Used for Vin

12.4.1.2. SIM Cards Used

Consumption measurement may be performed with either 3-Volt or 1.8-Volt SIM cards. However, all specified consumption values in this section are for a 3-Volt SIM card.

Caution: *The SIM card's voltage is supplied by the GL61x0 power supply. Consumption measurement results may vary depending on the SIM card.*

12.4.2. Software Configuration

This section defines the software configuration for the equipment(s) used and the GL61x0 settings.

12.4.2.1. GL61x0 Configuration

The GL61x0 software configuration is performed by selecting the operating mode to use in performing the measurement.

A description of the operating modes and the procedures used to change operating modes are given in the appendix of document [7] Firmware 7.42 AT Commands Manual (Sierra Wireless Software Suite 2.32).

Refer to the following list for the available operating modes of the GL61x0:

- Active Idle Mode
- Sleep Idle Mode (only available on GL6100)
- Active Mode
- Sleep Mode (only available on GL6100)
- Connected Mode
- Transfer Mode class 8 (4Rx/1Tx) (in GPRS mode)
- Transfer Mode class 10 (3Rx/2Tx) (in GPRS mode)

12.4.2.2. Equipment Configuration

The communication tester is set according to the GL61x0 operating mode. Paging during idle modes, Tx burst power, RF band and GSM/DCS/GPRS may be selected on the communication tester.

Refer to the following table for the network analyzer configuration according to operating mode.

Table 50. Operating Mode Information

Operating Mode	Communication Tester Configuration	
Alarm Mode	N/A	
Active Idle Mode	Paging 9 (Rx burst occurrence ~2s)	
	Paging 2 (Rx burst occurrence ~0,5s)	
Sleep Idle Mode	Paging 9 (Rx burst occurrence ~2s)	
	Paging 2 (Rx burst occurrence ~0,5s)	
Active Mode	N/A	
Sleep Mode	N/A	
Connected Mode	850/900 MHz	PCL5 (TX power 33dBm)

Operating Mode		Communication Tester Configuration	
		1800/1900 MHz	PCL19 (TX power 5dBm)
			PCL0 (TX power 30dBm)
			PCL15 (TX power 0dBm)
GPRS	Transfer Mode class 8 (4Rx/1Tx)	850/900 MHz	Gam.3 (TX power 33dBm)
			Gam.17 (TX power 5dBm)
		1800/1900 MHz	Gam.3 (TX power 30dBm)
			Gam.18 (TX power 0dBm)
	Transfer Mode class 10 (3Rx/2Tx)	850/900 MHz	Gam.3 (TX power 33dBm)
			Gam.17 (TX power 5dBm)
1800/1900 MHz		Gam.3 (TX power 30dBm)	
		Gam.18 (TX power 0dBm)	

13. Reliability Standards: Compliance and Recommendations

13.1. Reliability Compliance

The GL61x0 is compliant with the following requirements:

Table 51. Standards Conformity for the GL61x0

Abbreviation	Definition
IEC	International Electro technical Commission
ISO	International Organization for Standardization

13.2. Applicable Standards Listing

The table hereafter gives the basic list of standards applicable to the GL61x0.

Note: References to any features can be found from these standards.

Table 52. Applicable Standards and Requirements for the GL61x0

Document	Current Version	Title
IEC6006826	7.0	Environmental testing - Part 2.6: Test FC: Sinusoidal Vibration.
IEC60068234	73	Basic environmental testing procedures part 2: Test FD: random vibration wide band - general requirements. Cancelled and replaced by IEC60068-2-64 . For reference only.
IEC60068264	2.0	Environmental testing - part 2-64: Test FH: vibration, broadband random and guidance.
IEC60068232	2.0	Basic environmental testing procedures - part 2: Test ED: (procedure 1) Withdrawn & replaced by IEC60068-2-31 . For reference only.
IEC60068231	2.0	Environmental testing part 2-31: Test EC: rough handling shocks, primarily for equipment-type specimens.
IEC60068229	2.0	Basic environmental testing procedures - part 2: Test EB and guidance: bump. Withdrawn and replaced by IEC60068-2-27 . For reference only.
IEC60068227	4.0	Environmental testing - part 2-27: Test EA and guidance: shock.
IEC60068214	6.0	Environmental testing - part 2-14: Test N: change of temperature.
IEC6006822	5.0	Environmental testing - part 2-2: Test B: dry heat.
IEC6006821	6.0	Environmental testing - part 2-1: Test A: cold.
IEC60068230	3.0	Environmental testing - part 2-30: Test DB: damp heat, cyclic (12 h + 12 h cycle).
IEC6006823	69 w/A1	Basic environmental testing procedures part 2: Test CA: damp heat, steady State. Withdrawn and replaced by IEC60068-2-78 . For reference only.
IEC60068278	1.0	Environmental testing part 2-78: Test CAB: damp heat, steady state.

Document	Current Version	Title
IEC60068238	2.0	Environmental testing - part 2-38: Test Z/AD: composite temperature/humidity cyclic test.
IEC60068240	1.0 w/A1	Basic environmental testing procedures - part 2: Test Z/AM combined cold/low air pressure tests.
ISO167501	2ND	Road vehicles - environmental conditions and testing for electrical and electronic equipment - part 1: general.
ISO167502	2ND	Road vehicles - environmental conditions and testing for electrical and electronic equipment - part 2: electrical loads.
ISO167503	2ND	Road vehicles - environmental conditions and testing for electrical and electronic equipment - part 3: mechanical loads.
ISO167504	2ND	Road vehicles - environmental conditions and testing for electrical and electronic equipment - part 4: climatic loads.
IEC60529	2.1 w/COR2	Degrees of protection provided by enclosures (IP code).
IEC60068217	4.0	Basic environmental testing procedures - part 2: Test Q: sealing.
IEC60068218	2.0	Environmental testing - part 2-18: Tests - R and guidance: water.
IEC60068270	1.0	Environmental testing - part 2: tests - test XB: abrasion of markings and letterings caused by rubbing of fingers and hands.
IEC60068268	1.0	Environmental testing - part 2: tests - test I: dust and sand.
IEC60068211	3.0	Basic environmental testing procedures, part 2: test KA: salt mist.
IEC60068260	2.0	Environmental testing - part 2: Test KE: flowing mixed gas corrosion test.
IEC60068252	2.0 w/COR	Environmental testing - part 2: Test KB: salt mist, cyclic (sodium chloride solution).

13.3. Environmental Specifications

The GL61x0 is compliant with the operating classes listed in the table below. The ideal temperature range of the environment for each operating class is also specified.

Table 53. Operating Class Temperature Range

Conditions	Temperature Range
Operating/Class A	-20°C to +55°C
Operating/Class B	-30°C to +75°C
Storage	-40°C to +75°C

13.3.1. Function Status Classification

The classes reported below comply with the Annex “ISO Failure Mode Severity Classification”, ISO Standard 7637, and Section 1.

Note: The word “function” used here only concerns the function performed by the GL61x0.

Table 54. ISO Failure Mode Severity Classification

Class	Definition
CLASS A	<p>All equipment/system functions are fulfilled normally (100% functional) during and after the constraint.</p> <p>The GL61x0 shall exhibit normal function during and after environmental exposure. The GL61x0 performance shall meet the minimum requirements of 3GPP or appropriate wireless standards.</p>
CLASS B	<p>All equipment/system functions are fulfilled normally during application of the constraint; however, one or several of them may be out of the specified tolerances. After application of the constraint, all functions automatically return within standard limits. The memories shall remain in compliance with Class A.</p> <p>The GL61x0 shall exhibit the possibility at all times to establish a voice, SMS or DATA call. Unless otherwise stated, full performance should return to normal after the external influence has been removed.</p>

13.4. Reliability Prediction Model

13.4.1. Life Stress Test

The following tests the GL61x0’s product performance.

Table 55. Life Stress Test

Designation	Condition
Performance Test PT3T° & PT 	Standard: N/A
	Special conditions: <ul style="list-style-type: none"> • Temperature: <ul style="list-style-type: none"> ▪ Class A: -20°C to +55°C ▪ Class B: -30°C to +75°C • Rate of temperature change: ± 3°C/min • Recovery time: 3 hours
	Operating conditions: Powered
	Duration: 10 days

13.4.2. Environmental Resistance Stress Test

The following tests the GL61x0's resistance to extreme temperature.

Table 56. Environmental Resistance Stress Test

Designation	Condition
Cold Test COT 	Standard: IEC 680068-2-1, Test Ab
	Special conditions: <ul style="list-style-type: none"> • Temperature: -40°C • Rate of temperature change: $dT/dt \geq \pm 3^\circ\text{C}/\text{min}$ • Recovery time: 3 hours
	Operating conditions: Un-powered
	Duration: 72 hours

13.4.3. Corrosive Resistance Stress Test

The following tests the GL61x0's resistance to corrosive atmosphere.

Table 57. Corrosive Resistance Stress Test

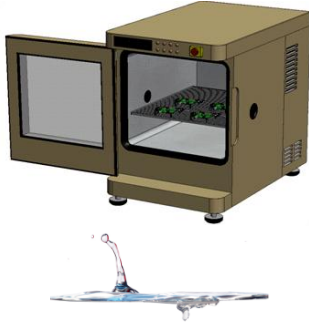
Designation	Condition
Moist Heat Cyclic Test MHCT 	Standard: IEC 60068-2-30, Test Db
	Special conditions: <ul style="list-style-type: none"> • Upper temperature: $+55 \pm 2^\circ\text{C}$ • Lower temperature: $+25 \pm 2^\circ\text{C}$ • RH: <ul style="list-style-type: none"> ▪ Upper temperature: 93% ▪ Lower temperature: 95% • Number of cycles: 21 (1 cycle/24 hours) • Rate of temperature change: $dT/dt \geq \pm 3^\circ\text{C}/\text{min}$ • Recovery time: 3 hours
	Operating conditions: Un-powered
	Duration: 21 days

13.4.4. Thermal Resistance Cycle Stress Test

The following tests the GL61x0's resistance to extreme temperature cycling.

Table 58. Thermal Resistance Cycle Stress Test

Designation	Condition
Thermal Shock Test TSKT 	Standard: IEC 60068-2-14
	Special conditions: <ul style="list-style-type: none"> • Upper temperature: +85°C • Lower temperature: -40°C • Rate of temperature change: 30s • Number of cycles: 200 • Duration of exposure: 30 minutes • Recovery time: 3 hours
	Operating conditions: Un-powered
	Duration: 72 hours

13.4.5. Mechanical Resistance Stress Tests

The following tests the GL61x0's resistance to vibrations and mechanical shocks.

Table 59. Mechanical Resistance Stress Tests

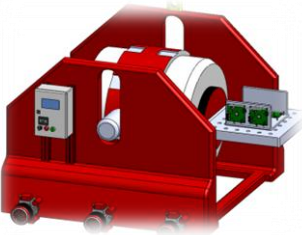
Designation	Condition
Sinusoidal Vibration Test SVT 	Standard: IEC 60068-2-6, Test Fc
	Special conditions: <ul style="list-style-type: none"> • Frequency range: 10Hz to 1000Hz <ul style="list-style-type: none"> ▪ Displacement: ±5mm (peak) • Frequency range: 16Hz to 62Hz <ul style="list-style-type: none"> ▪ Acceleration: 5G • Frequency range: 62Hz to 200Hz <ul style="list-style-type: none"> ▪ Acceleration: 3G • Frequency range: 200Hz to 1000Hz <ul style="list-style-type: none"> ▪ Acceleration: 1G • Sweep rate: 1 oct/min. • Test duration: 20 cycles • Sweep directions: X, Y and Z
	Operating conditions: Un-powered
	Duration: 72 hours
Random Vibration Test	Standard: IEC 60068-2-64

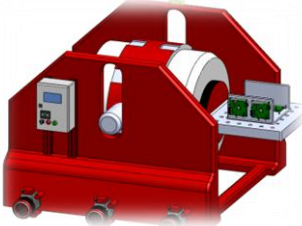
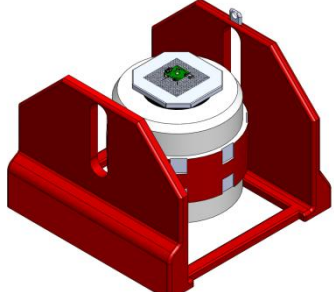
Designation	Condition
<p>RVT</p> 	<p>Special conditions:</p> <ul style="list-style-type: none"> • Density spectrum: 0.96m²/s³ • Frequency range: <ul style="list-style-type: none"> ▪ 0.1 g²/Hz at 10Hz ▪ 0.01 g²/Hz at 250Hz ▪ 0.0005 g²/Hz at 1000Hz ▪ 0.0005 g²/Hz at 2000Hz • Slope: -3dB/octave • Acceleration: 0.9gRMS • Number of axis: 3 <p>Operating conditions: Un-powered</p> <p>Duration: 16 hours</p>
<p>Mechanical Shock Test MST</p> 	<p>Standard: IEC 60068-2-27, Test Ea</p> <p>Special conditions:</p> <ul style="list-style-type: none"> • Shock Test 1: <ul style="list-style-type: none"> ▪ Wave form: Half sine ▪ Peak acceleration: 30G ▪ Duration: 11ms ▪ Number of shocks: 8 per direction ▪ Number of directions: 6 (±X, ±Y, ±Z) • Shock Test 2: <ul style="list-style-type: none"> ▪ Wave form: Half sine ▪ Peak acceleration: 200G ▪ Duration: 3ms ▪ Number of shocks: 3 per direction ▪ Number of directions: 6 (±X, ±Y, ±Z) • Shock Test 3: <ul style="list-style-type: none"> ▪ Wave form: Half sine ▪ Peak acceleration: 100G ▪ Duration: 6ms ▪ Number of shocks: 3 per direction ▪ Number of directions: 6 (±X, ±Y, ±Z) <p>Operating conditions: Un-powered</p> <p>Duration: 72 hours</p>

13.4.6. Handling Resistance Stress Tests

The following tests the GL61x0's resistance to handling malfunctions and damages.

Table 60. Handling Resistance Stress Tests

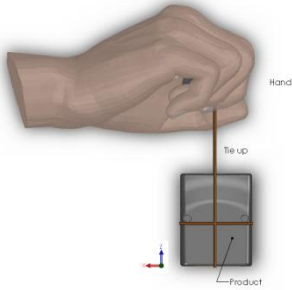
Designation	Condition
ESD Test 	Standard: IEC 1000-4-2
	Special conditions: <ul style="list-style-type: none"> Contact discharges: 10 positive and 10 negative applied Voltage: ±2kV, ±4kV, ±6kV
	Operating conditions: Powered
	Duration: 24 hours
Operational Durability OD	Standard : N/A
	Special conditions: <ul style="list-style-type: none"> SIM Connector: <ul style="list-style-type: none"> Cycles : 40 Repetition Rate : 3s per cycle Objective : Mating and de-mating System Connector: <ul style="list-style-type: none"> Cycles : 40 Repetition Rate : 3s per cycle Objective : Mating and de-mating RF Connector : <ul style="list-style-type: none"> Cycles : 20 Repetition Rate : 5s per cycle Objective : Mating and de-mating
	Operating conditions: Un-powered
	Duration: 24 hours
Free Fall Test FFT 	Standard : IEC 60068-2-32, Test Ed
	Special conditions: <ul style="list-style-type: none"> Drop: 2 samples for each direction Equivalent drop height: 1.5m Number of directions: 6 (±X, ±Y, ±Z) Number of drops/face: 2
	Operating conditions: Un-powered
	Duration: 24 hours

14. Recommendations When Using the GL61x0 on Trucks

Caution: The power supply connection of the GL61x0 must never be directly connected to the truck battery. For the GL6110 – USB, it should connect to the USB port of the Car PC accordingly.

14.1. Recommended Power Supply Connection on Trucks

All trucks have a circuit breaker on the exterior of the cabin. The circuit breaker is used for safety reasons: if a fire blazes in the trucks, (for example, on the wiring trunk) the driver may cut the current source to avoid any damage (explosion). The circuit breaker is connected to the truck ground, most often associated with the fuse box.

Most truck circuit breakers do not cut the Positive Supply line of the battery, but cut the ground line of the latter.

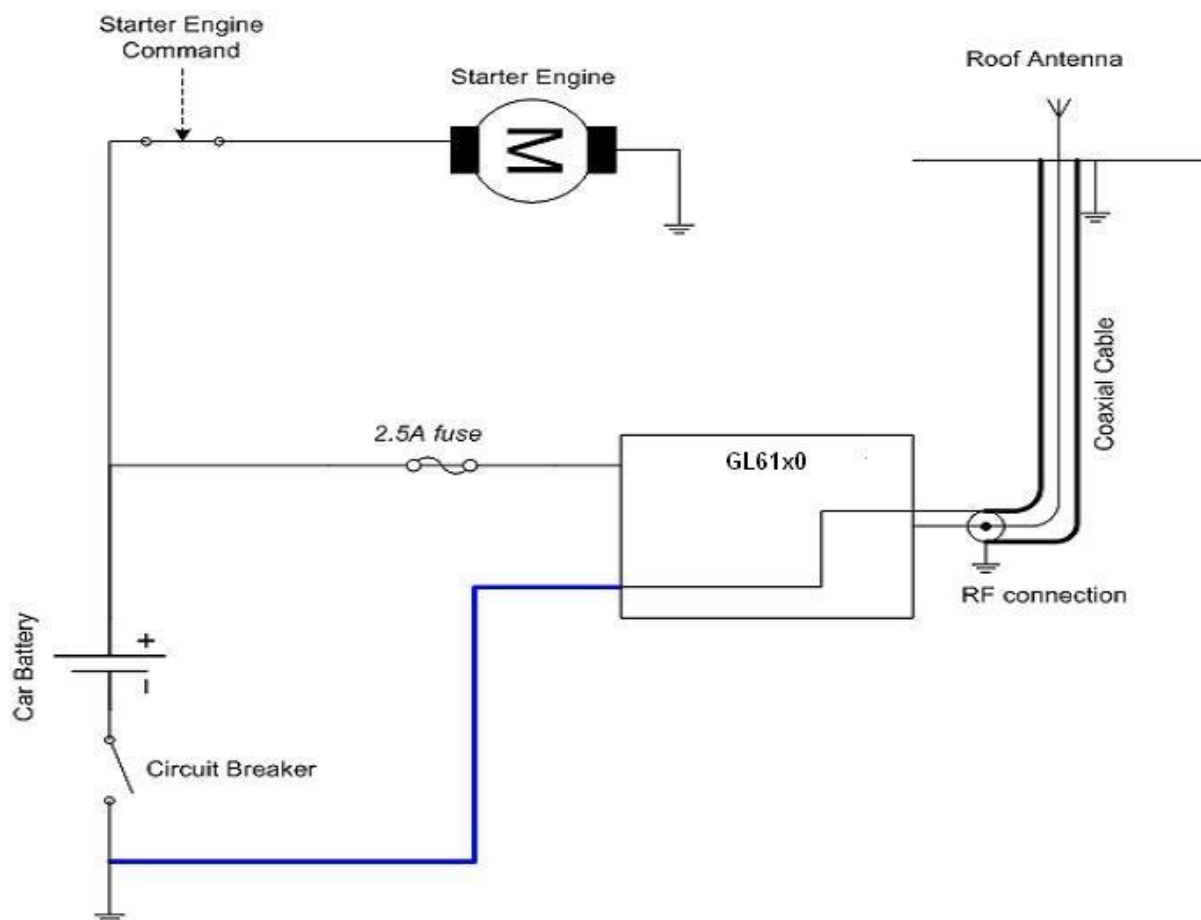

Figure 30. Recommended Power Supply Connection on Trucks

The figure above shows the recommended power supply connection where the ground connection of the GL61x0 is not directly connected to the battery but is connected after the Circuit Breaker (on the truck ground or the fuse box).

14.2. Technical Constraints on Trucks

It is highly recommended to directly connect the power supply on the circuit breaker rather than on the battery. The GL61x0 may be damaged when starting the truck if the circuit breaker is switched OFF (in this case, the truck ground and the battery ground will be connected through the GL61x0 as shown in the following figure).

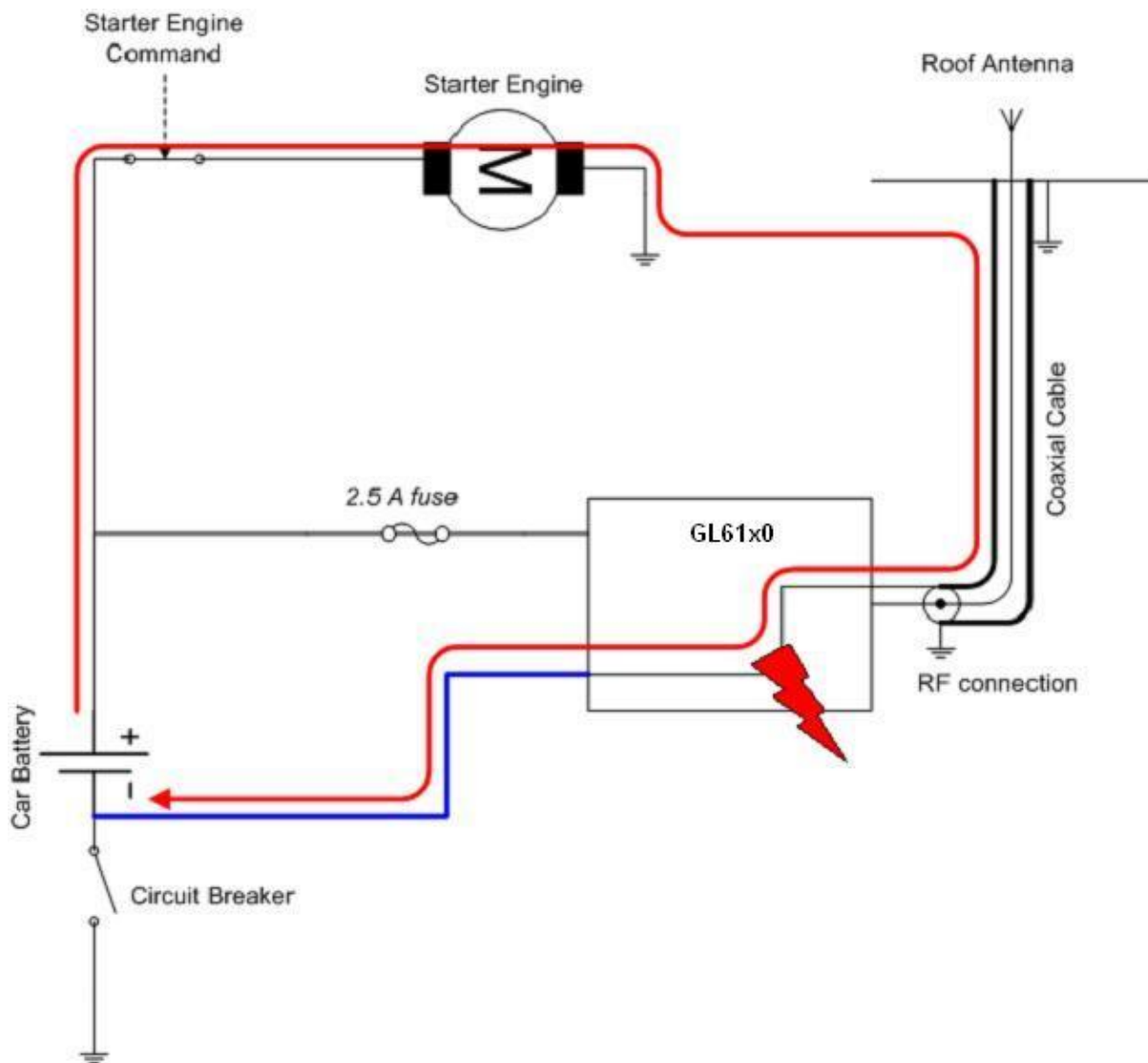

Figure 31. Example of an Electrical Connection Which May Damage the GL61x0

The figure above gives an example of an electrical connection which may dramatically damage the GL61x0 when its ground connection is directly connected to the battery ground.

In this example, when the circuit breaker is switched OFF, the current flows through the GL61x0 and powers the electrical circuit of the truck (for example, the dashboard).

Furthermore, when the Starter Engine command is used, it will destroy the cables or the GL61x0.

Since the internal tracks of the GL61x0 are not designed to support high currents (up to 60A when starting the truck), they will be destroyed.

15. Certification Compliance and Recommended Standards

15.1. Certification Compliance

The GL61x0 is compliant with the following requirements.

Table 61. Standards Conformity for the GL61x0

Domain	Applicable Standard
Safety standard	EN 60950-1 (ed.2006)
Health standard (EMF Exposure Evaluation)	EN 62311 (ed. 2008)
Efficient use of the radio frequency spectrum	EN 301 511 (V 9.0.2)
EMC	EN 301 489-1 (v1.8.1) EN 301 489-7 (v1.3.1)
FCC	FCC Part 15 FCC Part 22, 24
IC	RSS-132 Issue 2 RSS-133 Issue 5

15.2. Applicable Standards Listing

The table hereafter gives the basic list of standards applicable for 2G (R99/Rel.4).

Note: References to any features can be found from these standards.

Table 62. Applicable Standards and Requirements for the GL61x0

Document	Current Version	Title
GCF	3.36.0	GSM Certification Forum - Certification Criteria
NAPRD	5.3	Overview of PCS Type certification review board (PTCRB) Mobile Equipment Type Certification and IMEI control
TS 51.010-1	9.0.0	3rd Generation Partnership Project; Technical Specification Group GSM/EDGE Radio Access Network; Digital cellular telecommunications system (Phase 2+); Mobile Station (MS) conformance specification; Part 1: Conformance specification
TS 51.010-2	9.0.0	3rd Generation Partnership Project; Technical Specification Group GSM/EDGE Radio Access Network; Mobile Station (MS) conformance specification; Part 2: Protocol Implementation Conformance Statement (PICS) proforma specification
TS 51.010-4	4.14.1	3rd Generation Partnership Project; Technical Specification Group GSM/EDGE Radio Access Network; Digital cellular telecommunications system (Phase 2+); Mobile Station (MS) conformance specification; Part 4: SIM Application Toolkit Conformance specification
EN 301 511	9.0.2	Global System for Mobile Communications (GSM); Harmonised standard for mobile stations in the GSM 900 and DCS 1800 bands covering essential requirements under article 3.2 of the R&TTE directive (1999/5/EC)

Document	Current Version	Title
TS 34.121-1	8.5.0	3rd Generation Partnership Project; Technical Specification Group Radio Access Network; User Equipment (UE) conformance specification; Radio transmission and reception (FDD); Part 1: Conformance specification
TS 34.121-2	8.5.0	3rd Generation Partnership Project; Technical Specification Group Radio Access Network User Equipment (UE) conformance specification; Radio transmission and reception (FDD); Part 2: Implementation Conformance Statement (ICS)
TS 34.123-1	8.5.0	3rd Generation Partnership Project; Technical Specification Group Terminals; User Equipment (UE) conformance specification; Part 1: Protocol conformance specification

16. Embedded Peripherals

This section enumerates the peripherals embedded within the GL61x0.

16.1. I/O Connector

The I/O connector applied on board is an 8-pin Micro-Fit connector. The connector information is listed in the table below.

Table 63. 8-pin Micro-Fit Connector

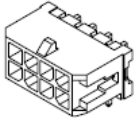
Supplier	Description	Vendor Part Number	
Molex	3.00mm Pitch Micro-Fit 3.0™ Header, Surface Mount Compatible, Dual Row, Right Angle, with Snap-in Plastic Peg PCB Lock, 8 Circuits, Tin (Sn) Plating, Glow Wire Compatible	430450800	

16.2. SIM Card Socket

The recommended SIM connector to use with the GL61x0 is described in the table below.

Table 64. Recommended SIM Card Socket

Manufacturer	Description	Order Number
KYOCERA	6 Positions, With (15.54mm Pitch) Boss, Without Lock	04 5036 006 299 862+

17. Recommended Connectors

This section lists the recommended connectors to use with the GL61x0.

17.1. GSM Antenna

GSM antennas and support for antenna adaptation can be obtained from manufacturers such as:

- ALLGON (<http://www.allgon.com>)
- HIRSCHMANN (<http://www.hirschmann.com/>)
- GiGa Concept (<http://www.gigaconcept.com/>)

18. Reference Documents

For more details, several reference documents can be consulted. The Sierra Wireless documents referenced herein are provided in the Sierra Wireless documentation package; however, the general reference documents which are not Sierra Wireless owned are not provided in the documentation package.

18.1. Sierra Wireless Software Documentation

- [1] Getting started with SDK 4.22b
Reference: WM_DEV_OAT_UGD_048
- [2] Tutorial for IDE 1.08 (if using IDE; obsolete if using Developer Studio)
Reference: WM_DEV_OAT_UGD_044
- [3] Tools Manual for IDE 1.08 (if using IDE; obsolete if using Developer Studio)
Reference: WM_DEV_OAT_UGD_045
- [4] Basic Development Guide for SDK4.22 (if using IDE; obsolete if using Developer Studio)
Reference: WM_DEV_OAT_UGD_050
- [5] ADL User Guide for SDK 4.22 (if using IDE; obsolete if using Developer Studio)
Reference: WM_DEV_OAT_UGD_051
- [6] SDK4.22 Official Release Note
Reference: WM_DEV_OAT_DVD_338

18.2. Firmware Documentation

- [7] Firmware 7.42 AT Commands Manual (Sierra Wireless Software Suite 2.32)
Reference: WM_DEV_OAT_UGD_079 (Version 14)
- [8] AT Commands Interface Guide
Reference: WM_ASW_OAT_UGD_00004

18.3. Other Related Documentation

- [9] AirPrime WMP100/150 Product Technical Specification and Customer Design Guideline
Reference: WM_DEV_WMP150_PTS_002
- [10] AirLink GL61x0 Cable Specifications
Reference: WA_DEV_GL61x0_PTS_002

18.4. General Reference Documentation

- [11] "I²C Bus Specification", Version 2.0, Philips Semiconductor 1998
- [12] ISO 7816-3 Standard

19. List of Abbreviations

Abbreviation	Definition
AC	Alternative Current
ADC	Analog to Digital Converter
A/D	Analog to Digital conversion
AF	Audio-Frequency
AT	ATtention (prefix for modem commands)
AUX	AUXiliary
CAN	Controller Area Network
CB	Cell Broadcast
CEP	Circular Error Probable
CLK	CLock
CMOS	Complementary Metal Oxide Semiconductor
CS	Coding Scheme
CTS	Clear To Send
DAC	Digital to Analogue Converter
dB	Decibel
DC	Direct Current
DCD	Data Carrier Detect
DCE	Data Communication Equipment
DCS	Digital Cellular System
DR	Dynamic Range
DSR	Data Set Ready
DTE	Data Terminal Equipment
DTR	Data Terminal Ready
EFR	Enhanced Full Rate
E-GSM	Extended GSM
EMC	ElectroMagnetic Compatibility
EMI	ElectroMagnetic Interference
EMS	Enhanced Message Service
EN	ENable
ESD	ElectroStatic Discharges
FIFO	First In First Out
FR	Full Rate
FTA	Full Type Approval
GND	GrouND
GPI	General Purpose Input
GPC	General Purpose Connector
GPIO	General Purpose Input Output
GPO	General Purpose Output
GPRS	General Packet Radio Service
GPS	Global Positioning System

Abbreviation	Definition
GSM	Global System for Mobile communications
HR	Half Rate
I/O	Input / Output
JTAG	Joint Test Action Group
LED	Light Emitting Diode
LNA	Low Noise Amplifier
MAX	MAXimum
MIC	MICrophone
MIN	MINimum
MMS	Multimedia Message Service
MO	Mobile Originated
MT	Mobile Terminated
na	Not Applicable
NF	Noise Factor
NMEA	National Marine Electronics Association
NOM	NOMinal
NTC	Négative Temperature Coefficient
PA	Power Amplifier
Pa	Pascal (for speaker sound pressure measurements)
PBCCH	Packet Broadcast Control CHannel
PC	Personal Computer
PCB	Printed Circuit Board
PDA	Personal Digital Assistant
PFM	Power Frequency Modulation
PSM	Phase Shift Modulation
PWM	Pulse Width Modulation
RAM	Random Access Memory
RF	Radio Frequency
RFI	Radio Frequency Interference
RHCP	Right Hand Circular Polarization
RI	Ring Indicator
RST	ReSeT
RTC	Real Time Clock
RTCM	Radio Technical Commission for Maritime services
RTS	Request To Send
RX	Receive
SCL	Serial CLock
SDA	Serial DAta
SIM	Subscriber Identification Module
SMS	Short Message Service
SPI	Serial Peripheral Interface
SPL	Sound Pressure Level
SPK	SPeaKer

Abbreviation	Definition
SW	SoftWare
PSRAM	Pseudo Static RAM
TBC	To Be Confirmed
TDMA	Time Division Multiple Access
TP	Test Point
TVS	Transient Voltage Suppressor
TX	Transmit
TYP	TYPical
UART	Universal Asynchronous Receiver-Transmitter
USB	Universal Serial Bus
USSD	Unstructured Supplementary Services Data
VSWR	Voltage Standing Wave Ratio
WMP	Wireless MicroProcessor

>> 20. Appendix A: Packaging

The GL61x0 comes in three package variants.

20.1. GL6100 2-Cable Package (antenna included)

The GL6100 2-cable package contains the following items:

1. GL6100
2. Adaptive Cable
3. DC Cable
4. Antenna



GL6100



Adaptive Cable

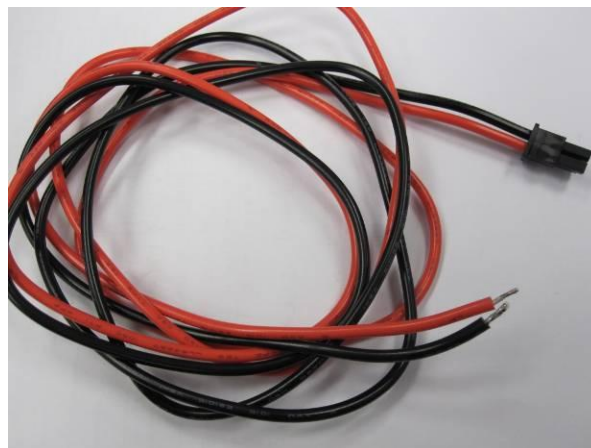

DC Cable



20.3. GL6110 Package

The GL6110 package contains the following items:

1. GL6110
2. FME Antenna
3. Micro-fit[®] USB Cable

	
<p>GL6110</p>	<p>FME Antenna</p>
	
<p>Micro-fit[®] USB Cable</p>	

➤➤ | 21. Appendix B: Product Labeling

Two product labels are available at the back of the GL61x0.

21.1. Model and MSN Label

The Model and MSN Label provides the following information:

- Product name
 - GL6100 RS232
 - GL6100 RS232 ESIM
 - GL6110 USB
- CE marking with certification number (in this case, CE0682)
- Open AT logo
- Serial number, 2D barcode
- WEEE logo



Figure 32. GL61x0 Model and MSN Label

21.2. IMEI and Approval Label

The IMEI and Approval Label provides the following information:

- IMEI number, 2D barcode
- ICCID number, 2D barcode (only applicable for GL6100 with Embedded SIM)
- FCC ID
- IC ID
- CMIID ID
- Company name (Sierra Wireless Asia Pacific)
- Operator name (only applicable for GL6100 with Embedded SIM)



Figure 33. GL61x0 IMEI and Approval Label

22. Appendix C: Safety Recommendations (for Information Only)

For the efficient and safe operation of your GSM device, please read the following information carefully.

22.1. RF Safety

22.1.1. General

Your GSM terminal is based on the GSM standard for cellular technology. The GSM standard is spread all over the world. It covers Europe, Asia and some parts of America and Africa. This is the most used telecommunication standard.

Your GSM terminal is actually a low power radio transmitter and receiver. It sends out and receives radio frequency energy. When you use your GSM application, the cellular system which handles your calls controls both the radio frequency and the power level of your cellular modem.

22.1.2. Exposure to RF Energy

There has been some public concern about possible health effects from using GSM terminals. Although research on health effects from RF energy has focused on the current RF technology for many years, scientists have begun research regarding newer radio technologies, such as GSM. After existing research had been reviewed, and after compliance to all applicable safety standards had been tested, it has been concluded that the product was fit for use.

If you are concerned about exposure to RF energy there are things you can do to minimize exposure. Obviously, limiting the duration of your calls will reduce your exposure to RF energy. In addition, you can reduce RF exposure by operating your cellular terminal efficiently by following the guidelines below.

22.1.3. Efficient Terminal Operation

For your GSM terminal to operate at the lowest power level, consistent with satisfactory call quality:

If your terminal has an extendible antenna, extend it fully. Some models allow you to place a call with the antenna retracted. However, your GSM terminal operates more efficiently with the antenna fully extended.

Do not hold the antenna when the terminal is « IN USE ». Holding the antenna affects call quality and may cause the modem to operate at a higher power level than needed.

22.1.4. Antenna Care and Replacement

Do not use the GSM terminal with a damaged antenna. If a damaged antenna comes into contact with the skin, a minor burn may result. Replace a damaged antenna immediately. Consult your manual to see if you may change the antenna yourself. If so, use only a manufacturer-approved antenna. Otherwise, have your antenna repaired by a qualified technician.

Use only the supplied or approved antenna. Unauthorized antennas, modifications or attachments could damage the terminal and may contravene local RF emission regulations or invalidate type approval.

22.2. General Safety

22.2.1. Driving

Check the laws and the regulations regarding the use of cellular devices in the area where you have to drive as you always have to comply with them. When using your GSM terminal while driving, please:

- give full attention to driving,
- pull off the road and park before making or answering a call if driving conditions so require.

22.2.2. Electronic Devices

Most electronic equipment, for example in hospitals and motor vehicles, is shielded from RF energy. However, RF energy may affect some improperly shielded electronic equipment.

22.2.3. Vehicle Electronic Equipment

Check your vehicle manufacturer representative to determine if any on-board electronic equipment is adequately shielded from RF energy.

22.2.4. Medical Electronic Equipment

Consult the manufacturer of any personal medical devices (such as pacemakers, hearing aids, etc...) to determine if they are adequately shielded from external RF energy.

Turn your terminal **OFF** in health care facilities when any regulations posted in the area instruct you to do so. Hospitals or health care facilities may be using RF monitoring equipment.

22.2.5. Aircraft

Turn your terminal OFF before boarding any aircraft.

- Use it on the ground only with crew permission.
- Do not use it in the air.

To prevent possible interference with aircraft systems, Federal Aviation Administration (FAA) regulations require you to have permission from a crew member to use your terminal while the aircraft is on the ground. To prevent interference with cellular systems, local RF regulations prohibit using your modem while airborne.

22.2.6. Children

Do not allow children to play with your GSM terminal. It is not a toy. Children could hurt themselves or others (by poking themselves or others in the eye with the antenna, for example). Children could damage the modem, or make calls that increase your modem bills.

22.2.7. Blasting Areas

To avoid interfering with blasting operations, turn your unit OFF when in a « blasting area » or in areas posted: « turn off two-way radio ». Construction crews often use remote control RF devices to set off explosives.

22.2.8. Potentially Explosive Atmospheres

Turn your terminal **OFF** when in any area with a potentially explosive atmosphere. It is rare, but your application or its accessories could generate sparks. Sparks in such areas could cause an explosion or fire resulting in bodily injuries or even death.

Areas with a potentially explosive atmosphere are often, but not always, clearly marked. They include fuelling areas such as petrol stations; below decks on boats; fuel or chemical transfer or storage facilities; and areas where the air contains chemicals or particles, such as grain, dust, or metal powders.

Do not transport or store flammable gas, liquid, or explosives in the compartment of your vehicle which contains your terminal or accessories.

Before using your terminal in a vehicle powered by liquefied petroleum gas (such as propane or butane) ensure that the vehicle complies with the relevant fire and safety regulations of the country in which the vehicle is to be used.



SIERRA
WIRELESS



element14

EN - For pricing and availability in your local country please visit one of the below links:

DE - Informationen zu Preisen und Verfügbarkeit in Ihrem Land erhalten Sie über die unten aufgeführten Links:

FR - Pour connaître les tarifs et la disponibilité dans votre pays, cliquez sur l'un des liens suivants:

[GL6100](#)

EN

This Datasheet is presented by
the manufacturer

DE

Dieses Datenblatt wird vom
Hersteller bereitgestellt

FR

Cette fiche technique est
présentée par le fabricant