

CC2560 Bluetooth® single-chip solution



Product Bulletin

Overview

The CC2560 from Texas Instruments is a complete *Bluetooth* Host Controller Interface (HCI) solution enabling ease of design as well as decreased time to market for *Bluetooth*-enabled devices in medical, industrial and consumer electronics applications. Based on TI's seventh-generation *Bluetooth* core, the CC2560 brings a product-proven solution that supports the *Bluetooth* 2.1 + EDR release, while the CC2564 is upgradable to *Bluetooth* Version 3.0 and *Bluetooth* low energy Version 4.0.

The CC2560 is the industry's first *Bluetooth* solution manufactured with TI's cutting-edge 65-nm CMOS process and DRP technology, delivering the industry's smallest single-chip solution along with low power and cost.

Advanced power management hardware and software algorithms provide significant power savings in the most commonly used *Bluetooth* modes of operation: active, page and inquiry scans.

RF performance

The CC2560 offers best-in-class *Bluetooth* RF performance for Tx power, Rx sensitivity and blocking. In addition, internal temperature detection and compensation ensures minimal variation in RF performance over temperature. The CC2560 RF transmitter is capable of receiving -95 dBm or transmitting up to +12 dBm (with level control) without the need for external power amplifiers or a Tx/Rx switch.

Key benefits

- Based on TI's cutting-edge 65-nm CMOS process and DRP technology, delivering the industry's smallest *Bluetooth* single-chip solution along with low power and cost
- Supports *Bluetooth* 2.1 + EDR release (CC2564 upgradable to *Bluetooth* Version 3.0 and *Bluetooth* Low Energy (BLE) Version 4.0)
- Flexibility for easy *Bluetooth* stack integration and validation into various microcontrollers, such as Stellaris® and low-end MSP430™ microcontrollers
- Best-in-class *Bluetooth* RF performance (Tx power, Rx sensitivity, blocking)
- Enhanced performance:
 - Improved *Bluetooth* link robustness supports power levels of *Bluetooth* Class 2 devices with increased output power capabilities
 - Improved adaptive frequency hopping algorithm with minimum adoption time

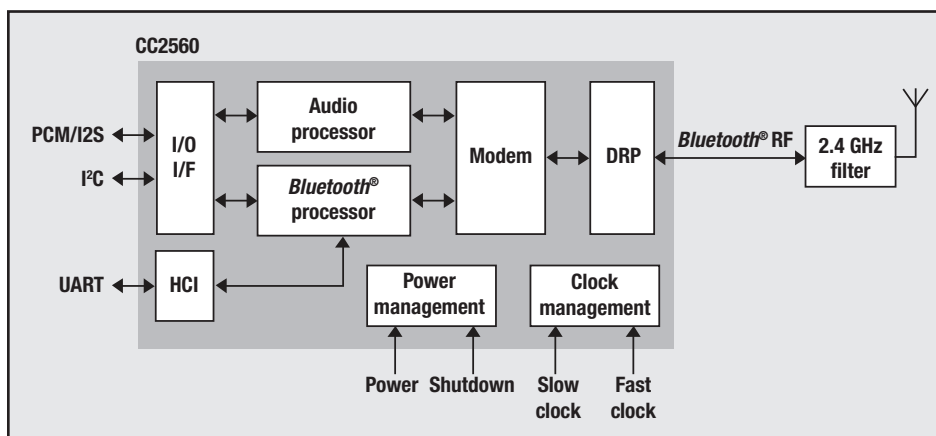

▲ CC2560 Bluetooth single-chip solution

Physical interfaces

TI's CC2560 offers flexible interfaces for easy integration into various host systems. These interfaces include:

- Standard HCI over H4 UART with a maximum rate of 4 Mbps
- Flexible pulse code modulation and I²S digital audio/voice interfaces:
 - Full flexibility of data format (linear, A-law, μ -law), data width, data order, sampling and slot positioning, master/slave modes, and high clock rates up to 15 MHz for slave mode or 4.096 MHz for master mode
 - Lost packet concealment for improved audio
- I²C to external EEPROM, which can be used for storing application-specific scripts.

Evaluation and development tools

To start developing today with the CC2560 *Bluetooth* solution, TI offers two evaluation and development options:

- eZ430-RF2560: a complete, low-cost TI *Bluetooth* evaluation and software development tool in a convenient USB stick. See www.ti.com/eZ430-rf2560-pb
- PAN1315 evaluation module kit (EMK): an advanced connectivity board based on Panasonic's PAN1315 *Bluetooth* module with direct connection to the MSP-EXP430F5438 experimenter board to take advantage of MSP430F5438 peripherals. See www.ti.com/pan1315-pb

Key benefits

- Advanced power management for extended battery life and ease of design:
 - On-chip power management, including direct connection to battery or DC to DC
 - Low power consumption for active, standby and scan *Bluetooth* modes
 - Proprietary low-power scan algorithm achieves page and inquiry scans at one-third the normal power
 - Shut-down and sleep modes to minimize power consumption when *Bluetooth* is not used
- Flexible clock management interface with support for:
 - Automatic fast-clock detection mechanism
 - Frequency adjustment to offset and drift

Technical Specifications

Parameter	Value	Condition/notes
Power supply voltage	1.7 to 4.8 V	Battery or DC to DC
Operating ambient temperature range	-40 to 85C	Industrial temperature range
Output power	+12 dBm	GFSK, typical
Receiver sensitivity	-95 dBm	GFSK, typical, dirty Tx on
Shut-down current	1 μ A	Typical
Deep sleep current	40 μ A	Typical
Ultra-low-power scan	135 μ A	1.28-second interval
EDR full throughput	39.2 mA	Tx = 3-DH1, Rx = 3-DH5
eSCO	8.3 mA	2-EV3 64 Kbps, no retransmission

Important Notice: The products and services of Texas Instruments Incorporated and its subsidiaries described herein are sold subject to TI's standard terms and conditions of sale. Customers are advised to obtain the most current and complete information about TI products and services before placing orders. TI assumes no liability for applications assistance, customer's applications or product designs, software performance, or infringement of patents. The publication of information regarding any other company's products or services does not constitute TI's approval, warranty or endorsement thereof.

B042210

The platform bar, MSP430 and Stellaris are trademarks of Texas Instruments. The *Bluetooth* word mark and logos are owned by the *Bluetooth* SIG, Inc., and any use of such marks by Texas Instruments is under license. All other trademarks are the property of their respective owners.

IMPORTANT NOTICE

Texas Instruments Incorporated and its subsidiaries (TI) reserve the right to make corrections, modifications, enhancements, improvements, and other changes to its products and services at any time and to discontinue any product or service without notice. Customers should obtain the latest relevant information before placing orders and should verify that such information is current and complete. All products are sold subject to TI's terms and conditions of sale supplied at the time of order acknowledgment.

TI warrants performance of its hardware products to the specifications applicable at the time of sale in accordance with TI's standard warranty. Testing and other quality control techniques are used to the extent TI deems necessary to support this warranty. Except where mandated by government requirements, testing of all parameters of each product is not necessarily performed.

TI assumes no liability for applications assistance or customer product design. Customers are responsible for their products and applications using TI components. To minimize the risks associated with customer products and applications, customers should provide adequate design and operating safeguards.

TI does not warrant or represent that any license, either express or implied, is granted under any TI patent right, copyright, mask work right, or other TI intellectual property right relating to any combination, machine, or process in which TI products or services are used. Information published by TI regarding third-party products or services does not constitute a license from TI to use such products or services or a warranty or endorsement thereof. Use of such information may require a license from a third party under the patents or other intellectual property of the third party, or a license from TI under the patents or other intellectual property of TI.

Reproduction of TI information in TI data books or data sheets is permissible only if reproduction is without alteration and is accompanied by all associated warranties, conditions, limitations, and notices. Reproduction of this information with alteration is an unfair and deceptive business practice. TI is not responsible or liable for such altered documentation. Information of third parties may be subject to additional restrictions.

Resale of TI products or services with statements different from or beyond the parameters stated by TI for that product or service voids all express and any implied warranties for the associated TI product or service and is an unfair and deceptive business practice. TI is not responsible or liable for any such statements.

TI products are not authorized for use in safety-critical applications (such as life support) where a failure of the TI product would reasonably be expected to cause severe personal injury or death, unless officers of the parties have executed an agreement specifically governing such use. Buyers represent that they have all necessary expertise in the safety and regulatory ramifications of their applications, and acknowledge and agree that they are solely responsible for all legal, regulatory and safety-related requirements concerning their products and any use of TI products in such safety-critical applications, notwithstanding any applications-related information or support that may be provided by TI. Further, Buyers must fully indemnify TI and its representatives against any damages arising out of the use of TI products in such safety-critical applications.

TI products are neither designed nor intended for use in military/aerospace applications or environments unless the TI products are specifically designated by TI as military-grade or "enhanced plastic." Only products designated by TI as military-grade meet military specifications. Buyers acknowledge and agree that any such use of TI products which TI has not designated as military-grade is solely at the Buyer's risk, and that they are solely responsible for compliance with all legal and regulatory requirements in connection with such use.

TI products are neither designed nor intended for use in automotive applications or environments unless the specific TI products are designated by TI as compliant with ISO/TS 16949 requirements. Buyers acknowledge and agree that, if they use any non-designated products in automotive applications, TI will not be responsible for any failure to meet such requirements.

Following are URLs where you can obtain information on other Texas Instruments products and application solutions:

Products		Applications	
Amplifiers	amplifier.ti.com	Audio	www.ti.com/audio
Data Converters	dataconverter.ti.com	Automotive	www.ti.com/automotive
DLP® Products	www.dlp.com	Communications and Telecom	www.ti.com/communications
DSP	dsp.ti.com	Computers and Peripherals	www.ti.com/computers
Clocks and Timers	www.ti.com/clocks	Consumer Electronics	www.ti.com/consumer-apps
Interface	interface.ti.com	Energy	www.ti.com/energy
Logic	logic.ti.com	Industrial	www.ti.com/industrial
Power Mgmt	power.ti.com	Medical	www.ti.com/medical
Microcontrollers	microcontroller.ti.com	Security	www.ti.com/security
RFID	www.ti-rfid.com	Space, Avionics & Defense	www.ti.com/space-avionics-defense
RF/IF and ZigBee® Solutions	www.ti.com/lprf	Video and Imaging	www.ti.com/video
		Wireless	www.ti.com/wireless-apps

Mailing Address: Texas Instruments, Post Office Box 655303, Dallas, Texas 75265
Copyright © 2010, Texas Instruments Incorporated