



HORNET SERIES (ORG14xx)

FULLY INTEGRATED GPS MODULE

Datasheet

OriginGPS.com

INDEX

Datasheet	1
1. SCOPE	5
2. DISCLAIMER	5
3. SAFETY INFORMATION	5
4. ESD SENSITIVITY	5
5. CONTACT INFORMATION	5
6. RELATED DOCUMENTATION	5
7. REVISION HISTORY	6
8. GLOSSARY	6
9. ABOUT HORNET FAMILY	7
10. ABOUT ORIGINGPS	7
11. DESCRIPTION	8
11.1. FEATURES	8
11.2. ARCHITECTURE	9
11.3. APPLICATIONS	11
12. ELECTRICAL SPECIFICATIONS	12
12.1. ABSOLUTE MAXIMUM RATINGS	12
12.2. RECOMMENDED OPERATING CONDITIONS	12
13. PERFORMANCE	14
13.1. ACQUISITION TIMES	14
13.2. SENSITIVITY	14
13.3. RECEIVED SIGNAL STRENGTHS	15
13.4. POWER CONSUMPTION	15
13.5. ACCURACY	16
13.6. DYNAMIC CONSTRAINS	16
14. POWER MANAGEMENT	17
14.1. POWER STATES	17
14.2. POWER SAVING MODES	17
15. EXTENDED FEATURES	20
15.1. ALMANAC BASED POSITIONING (ABP™)1	20
15.2. ACTIVE JAMMER REMOVER	20
15.3. CLIENT GENERATED EXTENDED EPHEMERIS (CGEE™)	20
16. INTERFACE	21
16.1. PAD ASSIGNMENTS	21
16.2. CONNECTIVITY	21
16.2.1. POWER	21
16.2.2. HOST CONTROL INTERFACE	22
16.2.3. HOST DATA INTERFACE	23
16.2.4. SMART SENSORS DATA INTERFACE	26
16.3. TYPICAL APPLICATION CIRCUIT	27
17. PCB LAYOUT	28
17.1. FOOTPRINT	28
17.2. DESIGN RESTRICTIONS	29
17.3. PLACEMENT	29
17.4. PCB STACK UP	30
18. OPERATION	31
18.1. STARTING THE MODULE	31
18.2. VERIFYING THE MODULE HAS STARTED	32
18.3. SHUTTING DOWN THE MODULE	32
19. SOFTWARE FUNCTIONS	32
19.1. NMEA	32
19.2. OSP™	34
20. HANDLING INFORMATION	38
20.1. PRODUCT PACKAGING AND DELIVERY	38

20.2.	MOISTURE SENSITIVITY	39
20.3.	ASSEMBLY	39
20.4.	REWORK	40
20.5.	ESD SENSITIVITY	40
20.6.	COMPLIANCES	40
20.7.	SAFETY INFORMATION	40
20.8.	DISPOSAL INFORMATION	41
21.	MECHANICAL SPECIFICATIONS	41
21.1.	ORG1400	41
21.2.	ORG1415	42
21.3.	ORG1418	42
22.	ORDERING INFORMATION	43
23.	DESIGN-IN CHECKLIST	44
23.1.	MODULE SELECTION	44
23.2.	SCHEMATICS VALIDATION	44
23.3.	LAYOUT VALIDATION	45

TABLE INDEX

TABLE 1 – RELATED DOCUMENTATION	5
TABLE 2 – REVISION HISTORY	6
TABLE 3 – ABSOLUTE MAXIMUM RATING	12
TABLE 4 – STANDARD AND PREMIUM SERIES OPERATING CONDITIONS	13
TABLE 5 – BASIC SERIES OPERATING CONDITIONS	14
TABLE 6 – ACQUISITION TIMES	14
TABLE 7 – SENSITIVITY	14
TABLE 8 – RECEIVED SIGNAL STRENGTH	15
TABLE 9 – STANDARD AND PREMIUM SERIES POWER CONSUMPTION @ $V_{CC} = 2V$ (AVERAGE)	15
TABLE 10 – BASIC SERIES POWER CONSUMPTION @ $V_{CC} = 1.8V$ (AVERAGE)	15
TABLE 11 – ACCURACY	16
TABLE 12 – DYNAMIC CONSTRAINS	16
TABLE 13 – ORG14XX PIN-OUT	21
TABLE 14 – UART BAUD RATE TOLERANCE	24
TABLE 15 – SPI TIMING	25
TABLE 16 – HARDWARE OPTION	31
TABLE 17 – STARTUP TIMING	32
TABLE 18 – NMEA PROTOCOL OUTPUT MESSAGES	33
TABLE 19 – NMEA PROTOCOL INPUT MESSAGES	33
TABLE 20 – OSP BINARY OUTPUT MESSAGES	34
TABLE 21 – OSP BINARY INPUT MESSAGES	35
TABLE 22 – OSP BINARY INPUT MESSAGES	36
TABLE 23 – OSP BINARY INPUT MESSAGES	37
TABLE 24 – CARRIER DIMENSIONS [mm]	38
TABLE 25 – REEL DIMENSIONS [mm]	39
TABLE 26 – REEL QUANTITY	39
TABLE 27 – ORG1400 MECHANICAL INFORMATION	41
TABLE 28 – ORG1415 MECHANICAL INFORMATION	42
TABLE 29 – ORG1418 MECHANICAL INFORMATION	42
TABLE 30 – FIRMWARE / HARDWARE OPTIONS	43
TABLE 31 – BOOT OPTIONS	44

FIGURE INDEX

FIGURE 1 – ORG14XX ARCHITECTURE	9
FIGURE 2 – GSD4e FUNCTIONAL BLOCK DIAGRAM	10
FIGURE 3 – ATP™ TIMING	18
FIGURE 4 – PTF™ TIMING	18
FIGURE 5 – APM™ TIMING	19
FIGURE 7 – ACTIVE JAMMER DETECTION FREQUENCY PLOT	20
FIGURE 8 – RECOMMEND ON_OFF TIMING	23
FIGURE 9 – UART INTEGRITY	24
FIGURE 10 – SPI TIMING	25
FIGURE 11 – UART INTERFACE CIRCUIT	27
FIGURE 12 – SPI INTERFACE CIRCUIT	28
FIGURE 13 – FOOTPRINT	28
FIGURE 15 – TYPICAL PCB STACK UP	30
FIGURE 16 – STARTUP TIMING	31
FIGURE 17 – CARRIER	38
FIGURE 18 – MODULE POSITION	38
FIGURE 19 – RECOMMENDED SOLDERING PROFILE	40
FIGURE 20 – ORG1400 MECHANICAL DRAWING	41
FIGURE 21 – ORG1415 MECHANICAL DRAWING	42
FIGURE 22 – ORG1418 MECHANICAL DRAWING	42

1. SCOPE

This document describes the features and specifications of Hornet series ORG14XX Modules.

2. DISCLAIMER

All trademarks are properties of their respective owners.

Performance characteristics listed in this document do not constitute a warranty or guarantee of product performance. OriginGPS assumes no liability or responsibility for any claims or damages arising out of the use of this document, or from the use of integrated circuits based on this document.

OriginGPS assumes no liability or responsibility for unintentional inaccuracies or omissions in this document. OriginGPS reserves the right to make changes in its products, specifications and other information at any time without notice.

OriginGPS reserves the right to conduct, from time to time, and at its sole discretion, firmware upgrades. As long as those FW improvements have no material change on end customers, PCN may not be issued. OriginGPS navigation products are not recommended to use in life saving or life sustaining applications.

3. SAFETY INFORMATION

Improper handling and use can cause permanent damage to the product.

4. ESD SENSITIVITY

This product is ESD sensitive device and must be handled with care.



5. CONTACT INFORMATION

Support - info@origingps.com or [Online Form](#)

Marketing and sales - marketing@origingps.com

Web – www.origingps.com

6. RELATED DOCUMENTATION

No	DOCUMENT NAME
1	Micro Spider – ORG4475 Evaluation Kit Datasheet
2	Micro Spider – ORG4475 Product Change Notification
3	Spider and Hornet - Software User Manual for CSR® based receivers
4	Spider and Hornet - NMEA Protocol Reference Manual for CSR® based receivers
5	Spider and Hornet - One Socket Protocol Reference Manual for CSR® based receivers
6	Spider and Hornet - Host Interface Application Note
7	Spider and Hornet - Low Power Modes Application Note
8	Spider and Hornet - Jammer Detector and Remover Application Note
9	Spider and Hornet - Client Generated Extended Ephemeris Application Note
10	Spider and Hornet - Server Generated Extended Ephemeris Application Note
11	Spider and Hornet - Ephemeris Push Application Note

TABLE 1 – RELATED DOCUMENTATION

7. REVISION HISTORY

REVISION	DATE	CHANGE DESCRIPTION
B01	January 1, 2012	First release
2.0	January 14, 2015	Format update
3.0	June 5, 2016	Power Modes update

TABLE 2 – REVISION HISTORY

8. GLOSSARY

A-GNSS Assisted **GNSS**

BPF Band Pass Filter

CE European Community conformity mark

CGEE™ Client Generated Extended Ephemeris

CMOS Complementary Metal-Oxide Semiconductor

COMPASS PRC GNSS (same as **BDS BeiDou-2** Navigation Satellite System)

EGNOS European Geostationary Navigation Overlay Service

EMC Electro-Magnetic Compatibility

ESD Electro-Static Discharge

EVb Evaluation Board

EVK Evaluation Kit

FCC Federal Communications Commission

GALILEO EU GNSS

GLONASS Global Navigation Satellite System

GNSS Global Navigation Satellite System

GPS Global Positioning System

I²C Inter-Integrated Circuit

IC Integrated Circuit

ISO International Organization for Standardization

LDO Low Dropout regulator

LGA Land Grid Array

LNA Low Noise Amplifier

MSAS Multi-functional Satellite Augmentation System

MSL Moisture Sensitivity Level

NFZ™ Noise-Free Zones System

NMEA National Marine Electronics Association

MEMS MicroElectroMechanical Systems

PCB Printed Circuit Board

PPS Pulse Per Second

QZSS Quasi-Zenith Satellite System

REACH Registration, Evaluation, Authorisation and Restriction of Chemical substances

RF Radio Frequency

RHCP Right-Hand Circular Polarized

RoHS Restriction of Hazardous Substances directive

ROM Read-Only Memory

RTC Real-Time Clock

SAW Surface Acoustic Wave

SBAS Satellite-Based Augmentation Systems

SGEE™ Server Generated Extended Ephemeris

SIP System In Package

SMD Surface Mounted Device

SMT Surface-Mount Technology
SOC System On Chip
SPI Serial Peripheral Interface
TCXO Temperature-Compensated Crystal Oscillator
TTF Time To First Fix
TTL Transistor-Transistor Logic
UART Universal Asynchronous Receiver/Transmitter
WAAS Wide Area Augmentation System

9. ABOUT HORNET FAMILY

Hornet family is offering the industry's smallest fully-integrated, highly-sensitive GPS and GNSS modules with integrated antennas or on-board RF connectors.

Hornet family features OriginGPS' proprietary NFZ™ technology for high sensitivity and noise immunity even under marginal signal condition, commonly found in urban canyons, under dense foliage or when the receiver's position in space rapidly changes.

Hornet family enables the shortest TTM (Time-To-Market) with minimal design risks.

Just connect power supply on a single layer PCB.

10. ABOUT ORIGINGPS

OriginGPS is a world leading designer, manufacturer and supplier of miniature positioning modules, antenna modules and antenna solutions.

OriginGPS modules introduce unparalleled sensitivity and noise immunity by incorporating Noise Free Zone system (NFZ™) proprietary technology for faster position fix and navigation stability even under challenging satellite signal conditions.

Founded in 2006, OriginGPS is specializing in development of unique technologies that miniaturize RF modules, thereby addressing the market need for smaller wireless solutions.

11. DESCRIPTION

OriginGPS has researched and enhanced the performance of standard GPS receivers in real life applications. OriginGPS in-house designed Microstrip Patch antennas with highest GPS-band performance and notch filtering for out-of band signals provides high selectivity. Furthermore, combined with internal RF shield and ground plane the ORG14XX series modules reveal excellent noise immunity and exceptional sensitivity. These carefully selected key components resulted in higher sensitivity, faster position fix, navigation stability and operation robustness under rapid environmental changes creating hard-to-achieve laboratory performance in heavy-duty environment.

11.1. FEATURES

- + Stand alone operation
- + OriginGPS Noise Free Zone System (NFZ™) technology
- + Integrated proprietary microstrip patch antenna element
- + Integrated LNA, SAW Filter, DC-DC buck regulator¹, I/O Buffers¹, TCXO and RTC
- + SiRFstarIV™ GSD4e GPS processor
- + L1 (1575MHz) frequency, C/A code
- + 48 track verification channels
- + Navigation sensitivity: -160dBm
- + Tracking sensitivity: -163dBm for indoor fixes
 - < 35s under Cold Start conditions
- + Fast TTFF: < 1s under Hot Start conditions
- + Multipath mitigation and indoor tracking
- + Active jammer remover: tracks up to 8 CW interferers and removes jammers up to 80dB-Hz
- + SBAS (WAAS, EGNOS, MSAS) support²
- + Assisted GPS (A-GPS) support
- + Almanac Based Positioning (ABP™)²
- + Client Generated Extended Ephemeris (CGEE™) and Server Generated Extended Ephemeris (SGEE™) for very fast TTFFs are supported through SiRFInstantFix™ and SiRFInstantFixII™
- + Automatic and user programmable power saving scenarios: ATP™, PTF™, APM™
- + Low power consumption: <20mW during ATP™
- + ARM7 109MHz baseband CPU
- + Smart sensor I²C master interface²
- + UART host interface, SPI optionally³
- + Programmable UART protocol and messages rate
- + Selectable NMEA or OSP (SiRF Binary) communication standards
- + Single voltage supply: wide input range¹ 2V - 6V with UVLO or 1.8V
- + Ultra small footprint: 17mm x 17mm
- + Surface Mount Device (SMD)
- + Industrial operating temperature range: -40 to 85°C
- + Pb-Free RoHS compliant

Notes:

1. Not available in Basic series
2. Available in Premium series only
3. Different ordering codes for SPI

11.2. ARCHITECTURE

ORG14XX SYSTEM CONFIGURATION

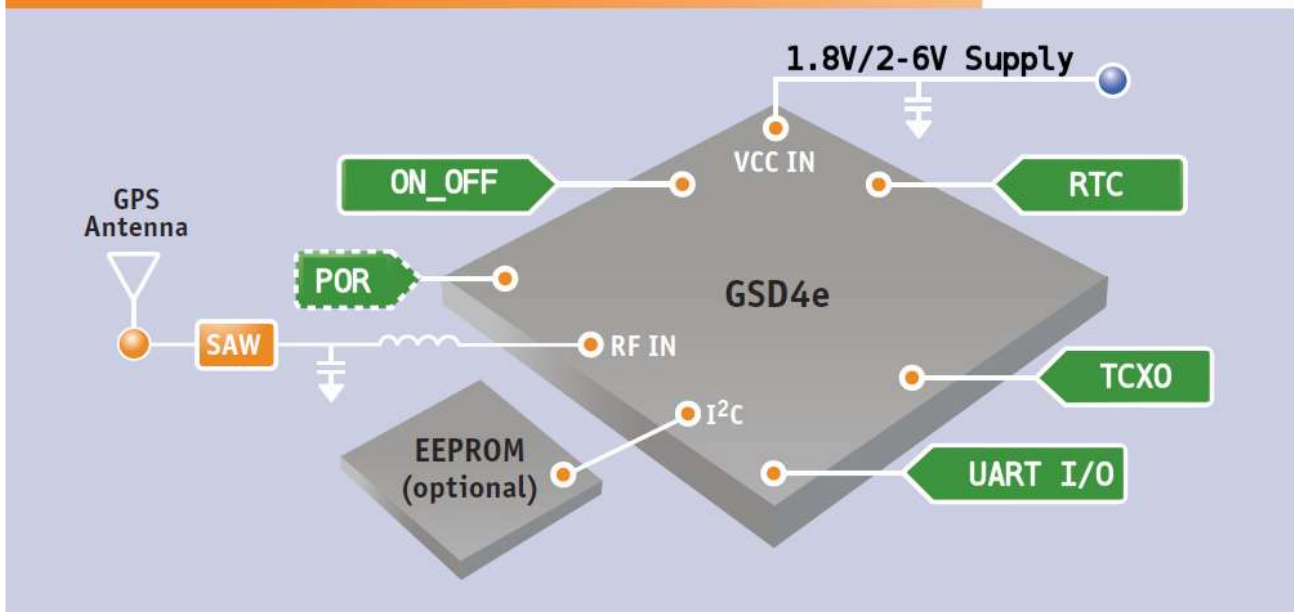

FIGURE 1 – ORG14XX ARCHITECTURE

+ Microstrip Patch Antenna

OriginGPS integrated microstrip patch antenna element collects signals at 1575 MHz from the medium and blocks out-of-GPS L1 band frequencies.

+ ESD Protection Device

ESD TVS diode provides protection for module circuitry from high voltage transients on embedded antenna.

+ Band-Pass SAW Filter

Band-pass SAW filter eliminates inter-modulated out-of-band signals that may corrupt GPS receiver performance.

+ LNA (Low Noise Amplifier)

The integrated LNA amplifies the GPS signal to meet RF down converter input threshold. Noise Figure optimized design was implemented to provide maximum sensitivity.

+ DC-DC Voltage Regulator

The high efficiency synchronous DC-DC step-down switch mode converter provides regulated voltage supply for GPS processor over wide input voltage range.

The design of this section was optimized for low ripple, low quiescent current and high PSRR.

+ TCXO (Temperature Compensated Crystal Oscillator)

This highly stable 16.369 MHz oscillator controls the down conversion process in RF block of the GPS processor. Highest characteristics of this component are important factors in sensitivity, fast TTFF and navigation stability.

+ RTC (Real Time Clock) crystal

This miniature component with very tight specifications is necessary for maintaining Hot Start and Warm Start capabilities.

+ POR (Power-On Reset) Generator

This low quiescent current supervisory circuit monitors voltage domains and provides trigger signal for module power-up.

+ EEPROM (Electrically Erasable Programmable Read-Only Memory)

The 1Mbit serial EEPROM device provides local storage for Client Generated and Server Generated Extended Ephemeris data as well as for patches for GPS processor ROM firmware.

+ RF Shield

RF enclosure avoids external interference to compromise sensitive circuitry inside the receiver. RF shield also blocks module's internal high frequency emissions from being radiated.

+ GSD4e IC

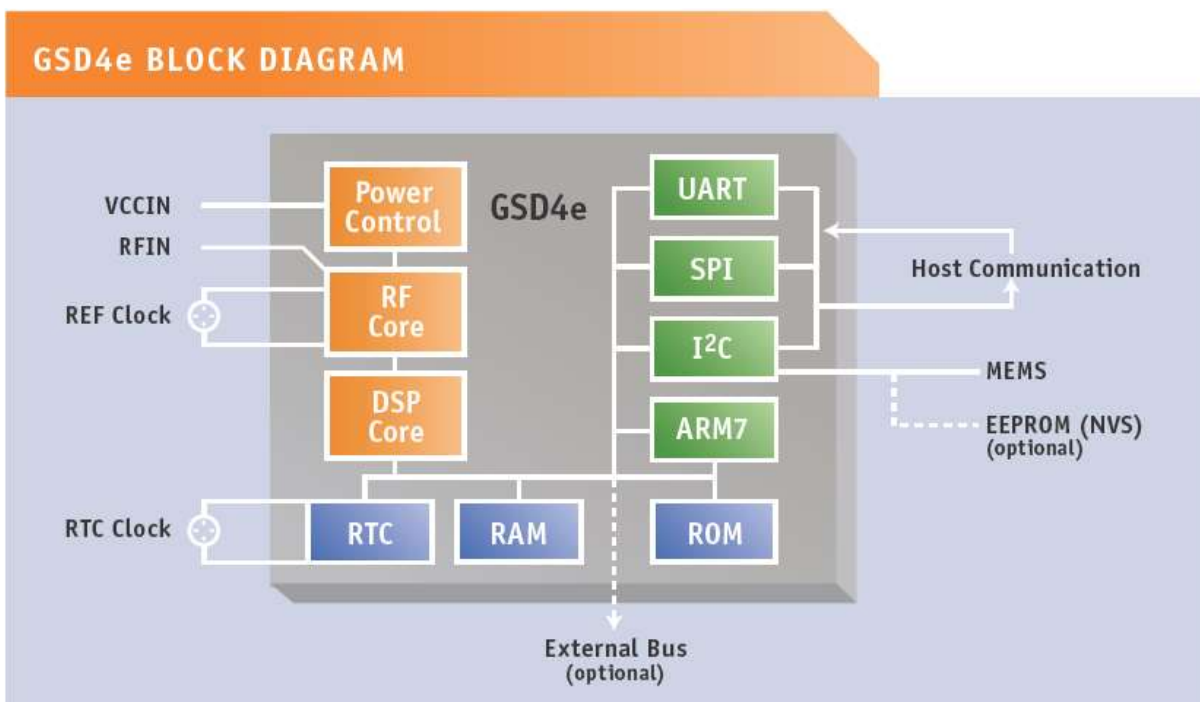

FIGURE 2 – GSD4e FUNCTIONAL BLOCK DIAGRAM

SiRFstarIV™ GSD4e is a navigation processor built on a low-power RF CMOS single-die, incorporating the baseband, integrated navigation solution software, ARM7 processor that form a complete stand alone or assisted-GPS engine.

SiRFstarIV™ GSD4e GPS processor includes the following units:

- + GPS RF core** incorporating LNA, down converter, fractional-N synthesizer and ADC block with selectable 2 and 4-bit quantization
- + GPS DSP core** incorporating more than twice the clock speed and more than double the RAM capacity relative to predecessor - market benchmarking SiRFStarIII™ GPS processor
- + ARM7 microprocessor system** incorporating 109MHz CPU and interrupt controller

- + ROM block as code storage for PVT applications
- + RAM block for data cache
- + RTC block
- + UART block
- + SPI block
- + Power control block for internal voltage domains management

11.3. APPLICATIONS

The ORG14XX series GPS antenna modules were specially designed to meet wide range of OEM configurations and applications.

ORG1400

The ORG1400 is low profile GPS antenna module.

The ORG1400 is ideal for portable electronics applications with direct satellite visibility:

- + Handheld consumer navigation and multifunction devices
- + Precise timing devices
- + Micro robots and micro UAVs
- + People and animal tracking systems

ORG1415

The ORG1415 is standard version of the ORG14XX series GPS antenna modules.

The ORG1415 is ideal for standard positioning and navigation applications including indoor tracking:

- + People and animal tracking systems
- + Sports and recreation accessories
- + Vehicle tracking and fleet management systems
- + Workforce management systems
- + Automotive navigation systems
- + Rescue and emergency systems
- + Marine navigation systems

ORG1418

The ORG1418 is enhanced sensitivity version of the ORG1415 GPS antenna module.

The ORG1418 is ideal for applications where module installation position and orientation limits satellite visibility:

- + Automotive security systems
- + Asset tracking SKU systems
- + Telemetric systems
- + Industrial navigation systems

12. ELECTRICAL SPECIFICATIONS

12.1. ABSOLUTE MAXIMUM RATINGS

Absolute Maximum Ratings are stress ratings only.

Stresses exceeding Absolute Maximum Ratings may damage the device.

Parameter		Symbol	Min	Max	Units
Power Supply Voltage	Basic series	VCC	-	2.2	V
	Standard and Premium series			6.5	V
TX Buffer Supply Voltage		VTX	-	5.5	V
TX Buffer Source/Sink Current		ITX	-10	10	mA
I/O Voltage		VIO	-0.3	3.6	V
I/O Source/Sink Current		IIO	-2	+2	mA
1.8V Source Current		I1V8		10	mA
ESD Rating		V(ESD)	-2	2	kV
Power Dissipation		PD	-	200	mW
Storage Temperature		TST	-55	+125	°C
Lead Temperature (10 sec. @ 1mm from case)		TLEAD		+260	°C

TABLE 3 – ABSOLUTE MAXIMUM RATING

12.2. RECOMMENDED OPERATING CONDITIONS

Functional operation above the Recommended Operating Conditions is not implied.

Extended exposure to stresses above the Recommended Operating Conditions may affect device reliability.

Standard and Premium Series							
Parameter	Symbo	Mode / Pad	Test Conditions	Min	Typ	Max	Units
Power Supply Voltage	VCC	VCC		2.0	3.3	6.0	V
			VCC falling		1.8	1.9	V
			VCC rising		1.9	2.0	V
Power Supply Current	ICC	Acquisition	-130dBm (Outdoor) VCC = 2V TAMB = 25°C		33	43	mA
		Tracking		7		33	mA
		CPU only1			14		mA
		Standby1			0.1		mA
		Hibernate			30	100	µA
		Shutdown			0.5	1	µA
1.8V Output Voltage	V1V8	V1V8		1.77	1.80	1.83	V
1.8V Output Current	I1V8	V1V8				20	mA
TX Buffer Supply Voltage	VTX	VTX		1.80		5	V
TX Buffer Supply Current	ITX	VTX			1	10	mA
Input Voltage Low State	VIL	UART/SPI/GPIO				0.45	V

Input Voltage Low State Input Voltage High State	VIL VIH	ON_OFF				0.3	V
		EN				0.6	V
	UART/SPI/GPIO		1.26			3.6	V
Input Voltage High State Output Voltage Low State	VIH VOL	ON_OFF		1.0		3.6	V
		EN		0.8		VCC	V
	UART	IOL = 4mA				0.4	V
Output Voltage Low State Output Voltage High State	VOL VOH	SPI / GPIO	IOL = 4mA			0.4	V
	UART		IOH = -4mA	VTX -0.4			V
Output Voltage High State Input Leakage Current	VOH IIN(leak)	SPI / GPIO	IOH = -4mA	1.35	1.71	1.8	V
		UART/SPI/GPIO T	VIN = 1.8V or 0V	-10		+10	μA
Input Leakage Current Input Capacitance	IIN(leak) CIN	ON_OFF	VIN = 1.8V or 0V	-0.2		+0.2	μA
		EN	VIN = VCC or 0V	-0.5	0.01	0.5	μA
	UART				4	10	pF
Input Capacitance Operating Temperature3	CIN TAMB	SPI / GPIO				5	pF
				-40	+25	+85	°C
Relative Humidity	RH		-40°C ≤ TAMB ≤ +85°C	5		95	%

TABLE 4 – STANDARD AND PREMIUM SERIES OPERATING CONDITIONS

Basic series								
Parameter	Symbol	Mode / Pad	Test Conditions	Min	Typ	Max	Units	
Power supply voltage	VCC	VCC		1.71	1.80	1.89	V	
Power Supply Current	ICC	Acquisition	-130dBm (Outdoor) TAMB = 25°C		33	43	mA	
		Tracking		7		33	mA	
		CPU only1			14			mA
		Standby1				0.1		mA
		Hibernate				20	30	μA
		Shutdown		Not				
1.8V Output Voltage	V1V8	V1V8					VCC	
Input Voltage Low State	VIL	UART/SPI/GPIO				0.45	V	
Input Voltage Low State Input Voltage High State	VIL VIH	ON_OFF				0.45	V	
		EN		Not				
		UART/SPI/GPIO		0.70•VCC				
Input Voltage High State Output Voltage Low State	VIH VOL	ON_OFF		0.70•VCC		3.6	V	
		EN		Not				
	UART/SPI/GPIO	IOL = 4mA						
Output Voltage High State	VOH	UART/SPI/GPIO	IOH = -4mA	0.75•VCC			V	
Input Leakage Current	IIN(leak)	All input pads	VIN = 1.8V or 0V	-10		+10	μA	
Input Capacitance	CIN	All input pads			5		pF	



Operating Temperature ³	TAMB			-40	+25	+85	°C
Relative Humidity	RH		-40°C ≤ TAMB ≤ +85°C	5		95	%

TABLE 5 – BASIC SERIES OPERATING CONDITIONS

Notes:

1. Transitional states of ATP™ low power mode
3. Operation below -20°C to -40°C and above +70°C to +85°C is accepted, but TTFF may increase

13. PERFORMANCE

13.1. ACQUISITION TIMES

TTFF (Time To First Fix) – is the period of time from GPS power-up till position estimation.

Hot Start

A hot start results from software reset after a period of continuous navigation or a return from a short idle period that was preceded by a period of continuous navigation.

In this state, all of the critical data (position, velocity, time, and satellite ephemeris) is valid to the specified accuracy and available in RAM.

Warm Start

A warm start typically results from user-supplied position and time initialization data or continuous RTC operation with an accurate last known position available in memory.

In this state, position and time data are present and valid, but ephemeris data validity has expired.

Cold Start

A cold start acquisition results when either position or time data is unknown.

Aided Start

Aiding is a method of effectively reducing the TTFF by making every start Hot or Warm.

	TTFF	Test Condition	Signal Level
Hot Start	< 1s	Outdoor, Static	-130 dBm
Aided Start ¹	< 10s		
Warm Start	< 32s		
Cold Start	< 35s		
Signal Reacquisition	< 1s		

TABLE 6 – ACQUISITION TIMES

13.2. SENSITIVITY

Test Condition	Signal Level
Tracking	-163 dBm
Navigation	-161 dBm (Deep Indoor)
Aided ¹	-156 dBm
Cold Start	-148 dBm

TABLE 7 – SENSITIVITY



13.3. RECEIVED SIGNAL STRENGTHS

	ORG1400	ORG1415	ORG1418
Average C/N02	40 dB-Hz	45 dB-Hz	48 dB-Hz

TABLE 8 – RECEIVED SIGNAL STRENGTH

Notes:

1. Host-assisted device by SGEE™ or self-assisted by CGEE™ or Ephemeris Push
2. Averaging of 5 SV's with highest C/N0 @ -130dBm, HDOP <1.5

13.4. POWER CONSUMPTION

Standard and Premium series	
Operation Mode	Power Consumption
Acquisition	80mW
Tracking	20-75mW
Hibernate	80μW

TABLE 9 – STANDARD AND PREMIUM SERIES POWER CONSUMPTION @ Vcc = 2V (AVERAGE)

Basic series	
Operation Mode	Power Consumption
Acquisition	100mW
Tracking	10-70mW
Hibernate	40μW

TABLE 10 – BASIC SERIES POWER CONSUMPTION @ Vcc = 1.8V (AVERAGE)



13.5. ACCURACY

		Method	Accuracy	Units	Test Conditions
Position	Horizontal	CEP (50%)	< 2.5	m	-130 dBm (Outdoor), Static
			< 2	m	-130 dBm (Outdoor), SBAS, Static
		2dRMS (95%)	< 5	m	-130 dBm (Outdoor), Static
			< 4	m	-130 dBm (Outdoor), SBAS, Static
	Vertical	VEP (50%)	< 4	m	-130 dBm (Outdoor), Static
			< 3	m	-130 dBm (Outdoor), SBAS, Static
		2dRMS (95%)	<7.5	m	-130 dBm (Outdoor), Static
			< 6	m	-130 dBm (Outdoor), SBAS, Static
Velocity	Horizontal	50%	< 0.01	m/s	-130 dBm (Outdoor), 30 m/s
Heading		50%	< 0.01	0	-130 dBm (Outdoor), 30 m/s
Time		1 PPS	< 1	µs	-130 dBm (Outdoor)

TABLE 11 – ACCURACY

13.6. DYNAMIC CONSTRAINS

Velocity <	515 m/s	1,000 knots
Acceleration <	4g	
Altitude <	18,288 m	60,000 ft.

TABLE 12 – DYNAMIC CONSTRAINS

Note: 1. Standard dynamic constrains according to regulatory limitations

14. POWER MANAGEMENT

14.1. POWER STATES

Full Power state (Acquisition/Tracking)

The module stays in full power until a position solution is made and estimated to be reliable.

During the acquisition, processing is more intense than during tracking, thus consuming more power.

CPU Only state

This is the state when the RF and DSP sections are partially powered off.

The state is entered when the satellites measurements have been acquired but the navigation solution still needs to be computed.

Standby state

This is the state when the RF and DSP sections are completely powered off and baseband clock is stopped.

Hibernate state

In this state the RF, DSP and baseband sections are completely powered off leaving only the RTC and Battery-Backed RAM running.

The module will perform Hot Start if held in Hibernate state less than 2 hours after valid position solution was acquired.

Shutdown state

In this state the ORG14XX series module is inhibited by driving EN input low.

The module will perform Cold Start after Shutdown state.

14.2. POWER SAVING MODES

The ORG14XX series module has three power management modes available in modules with Basic firmware – ATP™, APM™ and PTF™, which are controlled by internal state machine. These modes provide different levels of power saving with different degradation level of position accuracy.

Adaptive Trickle Power (ATP™)

Adaptive Trickle Power (ATP™) is best suited for applications that require navigation solutions at a fixed rate as well as low power consumption and an ability to track weak signals.

This power saving mode provides the most accurate position.

In ATP™ mode the ORG14XX module is intelligently cycled between Full Power, CPU Only and Standby states to optimize low power operation.

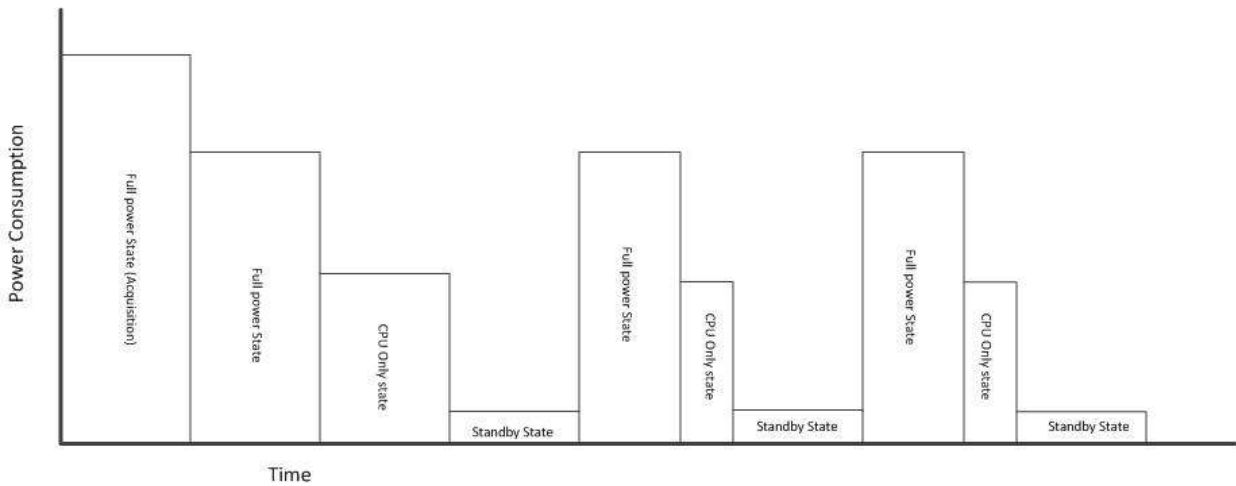

FIGURE 3 – ATP™ TIMING

Push-to-Fix (PTF™)

Push-to-Fix (PTF™) is best suited for applications that require infrequent navigation solutions, optimizing battery life time.

In PTF™ mode the ORG14XX module is mostly in Hibernate state, waked up for Ephemeris and Almanac refresh in fixed periods of time.

The PTF™ period is 30 minutes by default but can be anywhere between 10 seconds and 2 hours.

When the PTF mode is enabled the receiver will stay in Full Power state until the good navigation solution is computed.

When the application needs a position report it can toggle the ON_OFF pad to wake up the module. In this case, a new PTF™ cycle with default settings begins.

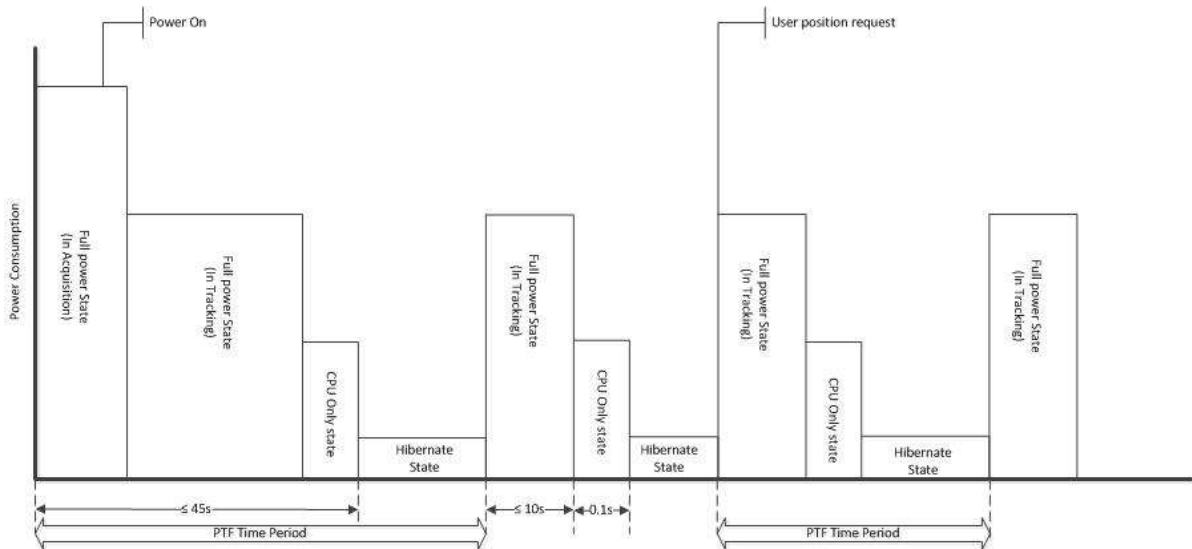

FIGURE 4 – PTF™ TIMING

Advanced Power Management (APM™)

Advanced Power Management (APM™) is designed for aided GPS applications.

Advanced Power Management (APM™) is designed to give the user more options to configure the power management. The APM™ mode allows power savings while ensuring that the Quality of the Solution (QoS) is maintained when signals level drop.

In addition to setting the position report interval, a QoS specification is available that sets allowable error estimates and selects priorities between position report interval and more power saving. The user may select between Duty Cycle Priority for more power saving and TBF (Time Between Fixes) Priority with defined or undefined maximum horizontal error.

TBF range is from 10 to 180 sec. between fixes, Power Duty Cycle range is between 5 to 100%.

Maximum position error is configurable between 1 to 160m.

The number of APM™ fixes is configurable up to 255 or set to continuous.

In APM™ mode the module is intelligently cycled between Full Power and Hibernate states.

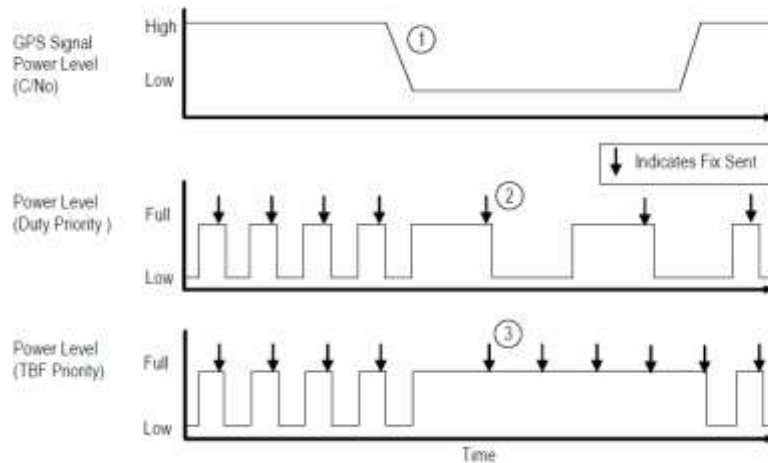

FIGURE 5 – APM™ TIMING

1. GPS signal level drops (e.g. user walks indoors)
2. Lower signal results in longer ON time. To maintain Duty Cycle, OFF time is increased.
3. Lower signal means missed fix. To maintain future TBFs, the module goes into Full Power state until signal levels improve.

15. EXTENDED FEATURES

15.1. ALMANAC BASED POSITIONING (ABP™)1

With ABP™ mode enabled, the user can get shorter Cold Start TTFF as a tradeoff with the position error.

When no sufficient Ephemeris data is available to calculate an accurate solution, a coarse solution will be provided where the position is calculated based on one or more of the SVs having their states derived from Almanac data.

Almanac data for ABP™ purposes may be stored factory set, broadcasted or pushed.

15.2. ACTIVE JAMMER REMOVER

Jamming Remover is an embedded DSP block that detects, tracks and removes up to 8 Continuous Wave (CW) type signals of up to 80dB-Hz each.

Jamming Remover is effective only against continuous narrow band interference signals and covers GPS L1 1575Mhz frequency ± 4 MHz.

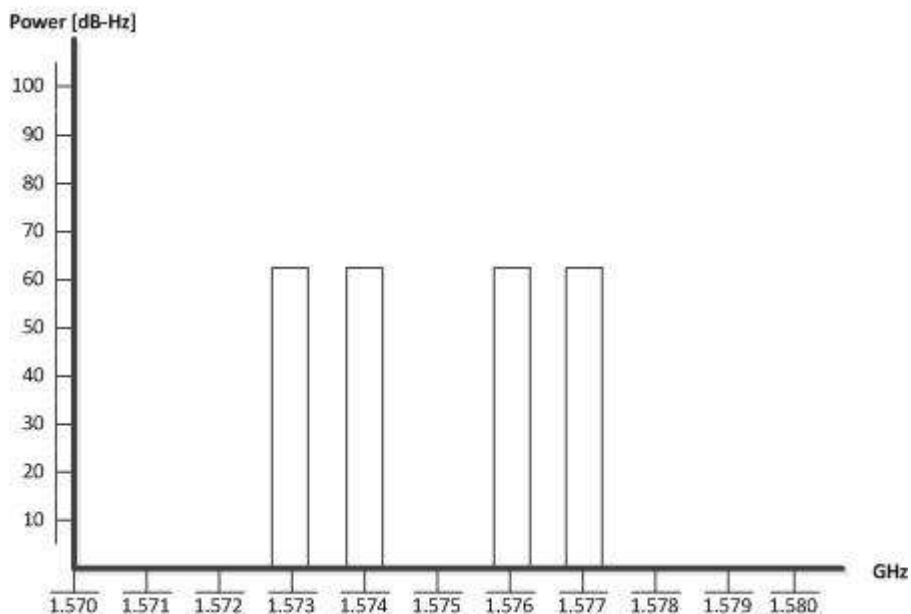

FIGURE 6 – ACTIVE JAMMER DETECTION FREQUENCY PLOT

15.3. CLIENT GENERATED EXTENDED EPHEMERIS (CGEE™)

The CGEE™ feature allows shorter TTFF by providing predicted (synthetic) ephemeris files created within a lost host system from previously received broadcast Ephemeris.

The prediction process requires good receipt of broadcast Ephemeris data for all satellites.

EE files created this way are good for up to 3 days and then expire.

The CGEE™ feature requires avoidance of power supply removal.

CGEE™ data files are stored on internal or external EEPROM or Serial Flash and managed by the receiver or storage and management is done by host.

Note:

1. Not available in modules with Standard firmware

16. INTERFACE

16.1. PAD ASSIGNMENTS

TABLE 13 – ORG14XX PIN-OUT

Pad Number	Pad Name	Pad Description	Direction	Default	Notes
1	RX	UART Receive	Input	High	1.8 – 3.6V
2	TX	UART Transmit	Output	High	High state voltage level is set by VTX
3	VTX	TX Buffer Power	Power		1.8 – 5.0V
4	SCK	SPI Clock	Input	Low	1.8 – 3.6V
5	nSE	SPI Chip Select	Input	High	
6	SDO	SPI Data Out	Output	High	
7	EN	Module Enable	Input	High	Drive low to inhibit the module
8	VCC	System Power	Power		2 - 6V
9	V1V8	1.8V Source	Power		Voltage source. Do not power this pad.
10	GND	System Ground	Power		
11	GND	System Ground	Power		
12	GND	System Ground	Power		
13	GND	System Ground	Power		
14	GND	System Ground	Power		
15	WAKEUP	Power Status	Output	Low	1.8V compatible
16	nRESET	Asynchronous Reset	Input	High	Do not drive
17	ON_OFF	Power State Control	Input	Low	1.8 – 3.6V
18	DR_SDA	Master I ² C SDA	Bi-dir	High	1.8V compatible
19	DR_SCL	Master I ² C SCL	Output	High	
20	EIT	External Interrupt	Input	High	1.8 – 3.6V
21	1PPS	UTC Time Mark	Output	Low	1.8V compatible
22	SDI	SPI Data In	Input	High	1.8 – 3.6V

16.2. CONNECTIVITY

16.2.1. POWER

The ORG14XX series module requires only one power supply VCC, which can be supplied directly from a battery since the module has internal regulators.

Power supply current consumption varies according to the processor load and satellite acquisition.

It is recommended to keep the power supply on all the time in order to maintain the non-volatile RTC and RAM active for fastest possible TTFF. When the VCC is powered off settings are reset to factory default and the receiver performs Cold Start on next power up.

Power supply – Basic series

In Basic series the VCC is 1.8V DC.

Typical ICC current is 37mA during acquisition. Peak ICC current is 60mA.

Typical ICC current in Hibernate state is 20µA.

Voltage ripple below 50mVPP allowed for frequency between 100KHz to 1MHz.
Voltage ripple below 15mVPP allowed for frequency above 1MHz.
Higher voltage ripple may compromise the ORG14XX series module performance.

Power supply – Standard and Premium series

In Standard and Premium series VCC range is 2 to 6V DC.
Typical ICC current is 23mA during acquisition. Peak ICC current is 50mA.
Typical ICC current in Hibernate state is 50 μ A.
Voltage ripple below 30mVPP allowed for frequency above 1MHz.
Higher voltage ripple may compromise the ORG14XX series module performance.
In Standard and Premium series the under voltage lockout (UVLO) circuit prevents the device from misoperation at low input voltages.
The UVLO circuit prevents the integrated DC-DC switch-mode regulator from turning on the switch or rectifier MOSFET under undefined conditions. It has a UVLO threshold set to 1.8V. Fully functional operation is permitted for input voltage down to the falling UVLO threshold level. The converter starts operation again once the input voltage trips the rising UVLO threshold level.

TX power

VTX power input is for integrated data output level shifter between 1.8V GPS processor domain and host.
VTX power supply range is 1.8 to 3.6V DC according to required TX output voltage swing.
Typical ITX current is 1mA and varies with input load of host.
VTX may be externally connected to VCC, while module and host I/O are in same voltage domain.
VTX may be externally connected to V1V8, while host I/O is in 1.8V voltage domain.
Data output level shifter is internally controlled by GPS processor and automatically turned off during low power states.

1.8V power source

V1V8 power supply provides regulated 1.8V voltage source for peripheral components, like MEMS sensors connected to DR I²C bus.
Maximum I1V8 continuous output current is 20mA.

Ground

Single Ground pad should be connected to host PCB Ground with shortest possible trace or via.

16.2.2. HOST CONTROL INTERFACE

ON OFF input

The ON_OFF control input is used to switch the receiver between different power states.

- +** If the system is in Hibernate state, an ON_OFF pulse will move to Full Power mode
 - +** If the system is in ATP™ mode, an ON_OFF pulse will move it to Full Power mode.
 - +** If the system is in PTF™ mode, an ON_OFF pulse will initiate one PTF™ cycle.
 - +** If the system is already in Full Power mode, an ON_OFF pulse will initiate orderly shutdown.
- ON_OFF pulse requires a rising edge and high level that persists for at least 100 μ s in order to be detected. Resetting the ON_OFF detector requires that ON_OFF go to logic low at least 100 μ s.
Recommended low-high-low pulse length is 100ms.
ON_OFF interrupts with less than 1 sec intervals are not recommended.
Multiple switch bounce pulses are recommended to be filtered out.

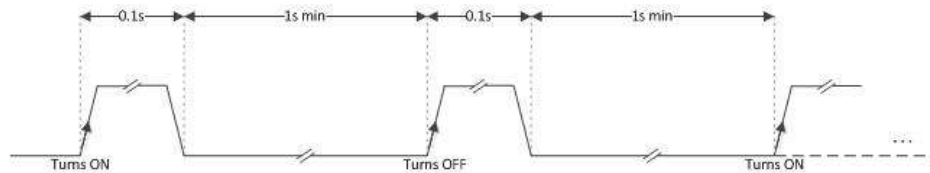

FIGURE 7 – RECOMMEND ON_OFF TIMING

ON_OFF input has internal pull-down resistor of 100kΩ.
ON_OFF pulse high state is 1.2 to 6V. Do not drive high permanently or pull-up this input.
Must be connected to host.

WAKEUP output

The WAKEUP pad is an output from the ORG14XX series module, used to flag for power state. A logic low on this output indicates that the module is in one of its low-power states - Hibernate or Standby. A logic high on this output indicates that the module is in Full Power state. In addition WAKEUP output can be used to control enable of auxiliary devices. Wakeup output is LVCMOS 1.8V compatible. Do not connect if not in use.

Enable input

The Enable control input can be used to fully inhibit the ORG14XX module. Enable signal is active low and has internal 100kΩ pull-up resistor. Do not connect to this input if the feature is not in use.

nRESET input

The Power-on-Reset (POR) is generated internally in the ORG14XX series module. Additionally, manual reset option is available through nRESET pad. Resetting the module clears the RTC block and configuration settings become default. nRESET signal should be applied for at least 1μs. nRESET input is active low and has internal pull-up resistor of 86kΩ. Do not drive this input high. Do not connect if not in use.

1PPS output

The pulse-per-second (PPS) output provides a pulse signal for timing purposes. Pulse length (high state) is 200ms about 1μs synchronized to full UTC second. The UTC time message is generated and put into output FIFO 300ms after PPS. The exact time between the PPS and UTC time message delivery depends on message rate, message queue and communication baud rate. 1PPS output is LVCMOS 1.8V compatible. Do not connect if not in use.

16.2.3. HOST DATA INTERFACE

The ORG14XX series module has 2 types of interface ports to connect to host: UART and SPI. The ORG14XX series module is factory set to support UART or SPI by internal configuration straps.

UART

The module has a 4-wire UART port:

- + TX used for GPS data reports. Output logic high voltage level is set by VTX.
- + RX used for receiver control. Input logic high voltage level is 1.45 to 3.6V.
- + nCTS is optionally used for hardware flow control.
- + High when host allows TX from the module. Input logic high voltage level is 1.45 to 3.6V.
- + nRTS is optionally used for hardware flow control.
- + High when module is ready to TX. Output logic high voltage level is 1.8V.

Operation:

The UART performs bit-by-bit transmitting and receiving in 8-bit octets when module is active. On the transmit side 1 start bit, 8 data bits and 2 stop bits followed by next character or idle line.

Designers should treat computations of maximum message output capacity from ORG14XX with 11-bits per transmitted character.

On the receive side 1 start bit, 8 data bits, 1 stop bit or longer is accepted.

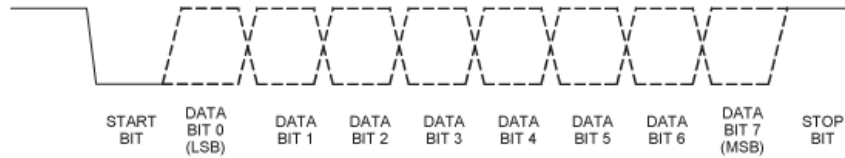

FIGURE 8 – UART INTEGRITY

Because UART transmission is asynchronous and sampled by the receiver, both sides require closely match bit-rate clocks, and that data bit waveform and timing distortion at the receiver should be limited.

The default protocol is NMEA@4,800bps.

The configuration for baud rates and respective protocols can be changed by commands via NMEA or OSP™ protocols.

Baud Rate (bps)	Error (%)	Baud Rate (bps)	Error (%)
4800	0.06	115200	0.24
9600	0.00	230400	1.04
19200	0.00	460800	0.60
38400	0.07	921600	2.40

TABLE 14 – UART BAUD RATE TOLERANCE

Maximum allowed clock rate difference between ORG14XX and host is 2.0% overall.

Maximum bit-edge distortion ≤ 5% bit length. Maximum bit jitter ≤ 5% bit length.

SPI

The SPI (Serial to Peripheral Interface) is a master/slave synchronous serial bus that consists of 4 signals:

- + Serial Clock (SCK) from master to slave.
- + Serial Data Out (also called Master Out Slave In or MOSI) from master.
- + Serial Data In (also called Master In Slave Out or MISO) from slave.
- + Chip Select (CS) from master.

The host interface SPI of the ORG14XX series module is a slave mode SPI.

The four SPI pads are RX (MOSI), TX (MISO), nRTS(nCS) and nCTS(SCK).

Output logic high voltage level is set by VTX. Inputs are 3.6V tolerant.

The host interface SPI features are:

- + TX and RX each have independent 1024 byte FIFO buffers.
- + RX and TX have independent, software specified two byte idle patterns of '0xA7 0xB4'.
- + TX FIFO is disabled when empty and transmits its idle pattern until re-enabled.
- + RX FIFO detects a software specified number of idle pattern repeats and then disables FIFO input until the idle pattern is broken.
- + FIFO buffers can generate an interrupt at any fill level.
- + SPI detects synchronization errors and can be reset by software.
- + Supports a maximum clock of 6.8MHz.
- + Default GPS data output format is NMEA standard.

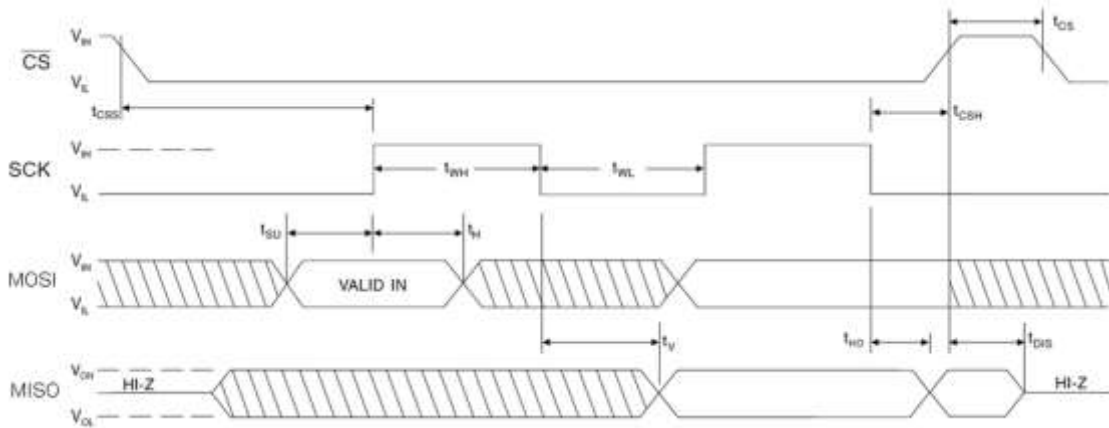

FIGURE 9 – SPI TIMING

Symbol	Parameter	Min	Max	Units
tCLK	SCK Time Period	140		ns
tCSS	nCS Setup Time	0.5	1	tCLK
tCS	nCS High Time	1		tCLK
tWH	SCK High Time	0.5		tCLK
tWL	SCK Low Time	0.5		tCLK
tCSH	nCS Hold Time	0.5	1	tCLK
tSU	Data In Setup Time	0.5		tCLK
tH	Data In Hold Time	0.5		tCLK
tV	Output Valid	0.5		tCLK
tHO	Output Hold Time	0.5		tCLK
tDIS	Output Disable Time		0.5	tCLK

TABLE 15 – SPI TIMING

Operation:

The SPI performs bit-by-bit transmitting and receiving at the same time whenever nCS is asserted and SCK is active. In order to communicate properly with SPI device, the protocol must be agreed – specifically- SPI mode and an idle byte pattern.

Among 4 SPI modes of the clock polarity (CPOL) and clock phase (CPHA) only SPI Mode 1 <CPOL="0", CPHA="1"> is currently supported:

- + At CPOL="0" the base value of the clock is zero.
- + For CPHA="1", data are read on the clock's falling edge and data are changed on a rising edge.

On power up, the first message to come out of the module is the "OK_TO_SEND" message. It takes about 20ms from power up for the module SPI drivers to get initialized.

The slave has no way of forcing data to the master to indicate it is ready for transmission - the master must poll the client periodically.

Since the specified idle 2-byte pattern for both receive and transmit is '0xA7 0xB4', the master can transmit this idle pattern into the slave repeatedly. If the master receives idle patterns back from the slave, it indicates that the slave currently has nothing to transmit but is ready to communicate.

On the module receive side, the host is expected to transmit idle pattern when it is querying the module's transmit buffer. In this way, the volume of discarded bytes is kept nearly as low as in the UART implementation because the module hardware does not place most idle pattern bytes in its RX FIFO. Most messaging can be serviced with polling. The FIFO thresholds are placed to detect large messages requiring interrupt-driven servicing.

On the module transmit side the intent is to fill the FIFO only when it is disabled and empty. In this condition, the module's SPI driver software loads as many queued messages as can completely fit in the FIFO. Then the FIFO is enabled.

The host is required to poll messages until idle pattern bytes are detected.

At this point the module's FIFO is empty and disabled, allowing the module's SPI driver to again respond to an empty FIFO interrupt and load the FIFO with any messages in queue.

Notes:

For SPI communication, read and write operations both require data being sent to the Slave SPI (idle bytes for reads and message data for writes). Any time data is sent to the module via the SPI bus, the Slave SPI of the module will send an equal amount of data back to the host.

These bytes must be buffered either in hardware or software, and it is up to the host to determine if the bytes received may be safely discarded (idle bytes), or should be passed on to the application handling GPS communication. Failure to properly handle data received from the SPI slave can result in corrupted GPS messages.

The external SPI master may send idle bytes and complete messages in a single transmission, provided that idle bytes shall not be inserted inside of a message.

The idle byte pattern and repeat count prevents the problem of messages lost due to normal occurrence of idle byte patterns within message data with high probability.

The external SPI master shall not send partial messages.

All transmissions from the SPI master shall be in multiples of 8 bits.

The external SPI master shall transmit the idle byte pattern when reading the SPI slave's transmit buffer when the master has no message data to transmit.

The SPI slave shall be serviced at a rate that will keep the TX FIFO empty.

16.2.4. SMART SENSORS DATA INTERFACE

The ORG14XX module master mode I²C interface provides optional support for Dead Reckoning (DR) and optional code patch upload.

This bus has 2 lines, DR_SCL and DR_SDA, both are pseudo open-drain and require external pull-up resistors. Discrete EIT input is optionally used to wake up the module from Hibernate state.

Dead Reckoning (DR) I²C Interface

The DR I²C interface supports required sensor instruments for dead reckoning applications such as gyros, accelerometers, compasses or other sensors that can operate with an I²C bus.

The ORG14XX module acts as the I²C Master and the sensor devices function in Slave mode.

This provides a very low latency data pipe for the critical sensor data so that it can be used in the Navigation Library and Kalman filter to enhance navigation performance.

The MEMS algorithms perform a sensor data fusion with the GPS signal measurements.

GPS measurements can be used to calibrate the MEMS sensors during periods of GPS navigation. The MEMS sensors can augment GPS measurements, and can be more accurate than GPS under degraded GPS signal conditions and certain dynamics.

DR I²C interface supports:

- + Common sensor formats
- + Typical data lengths (command + in/data out) of several bytes
- + Standard I²C bus maximum data rate 400kbps
- + Minimum data rate 100kbps

In current Premium firmware implementation, MEMS sensors integration provides a pseudo "position pinning" feature to prevent position wander and heading instability.

EIT input

The EIT (External Interrupt) input is optionally used by external sensors to provide a discrete interrupt to the module when a change of state is detected.

The input is either a level triggered or an edge triggered programmable for high/ low level or rising/falling edge. The input is disabled during initial power-up or reset.

EIT interrupt input logic high state is 1.8 to 3.6V.
Do not connect to this input if the feature is not in use.

Data Storage Support

The DR I²C interface is available at boot-up for uploading data from a serial EEPROM. Firmware updates may be provided from time to time to address ROM firmware issues as a method of performance improvement.

The DR I²C interface also supports serial flash devices used to store ARM7TDMI patch loads, including optional:

- + FIFO support
- + ARM7TDMI dedication to I²C interface during serial flash read or write

16.3. TYPICAL APPLICATION CIRCUIT

UART Host Interface – ordering codes R01, R02

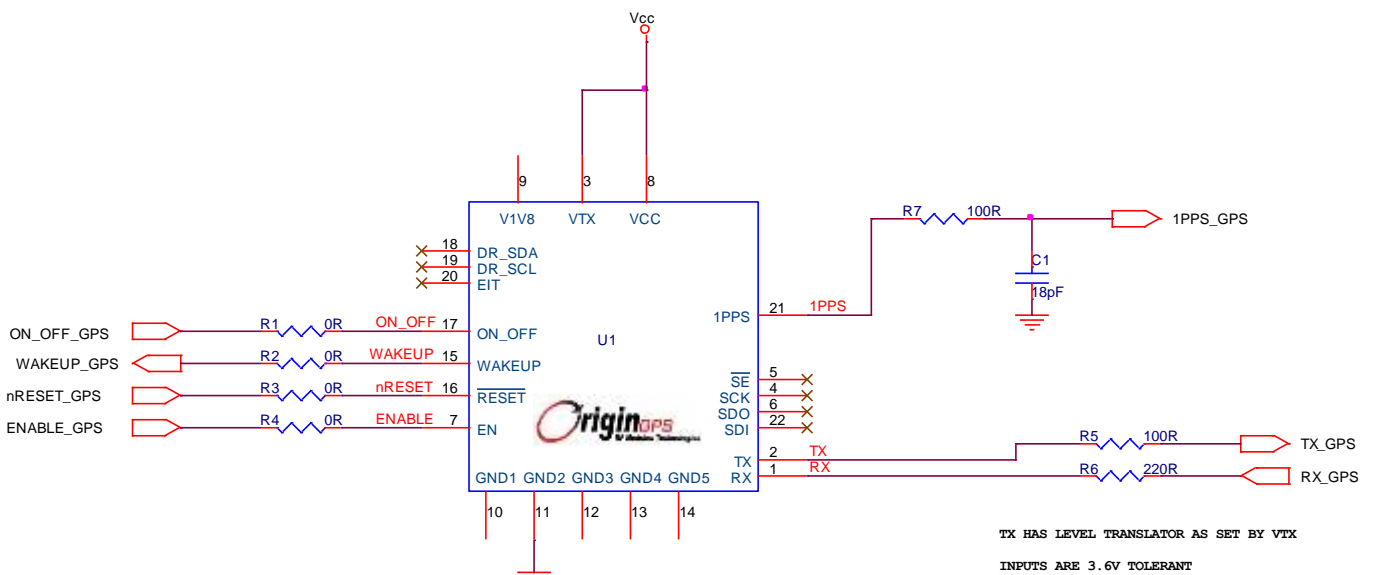

FIGURE 10 – UART INTERFACE CIRCUIT

SPI Host Interface – ordering code R03

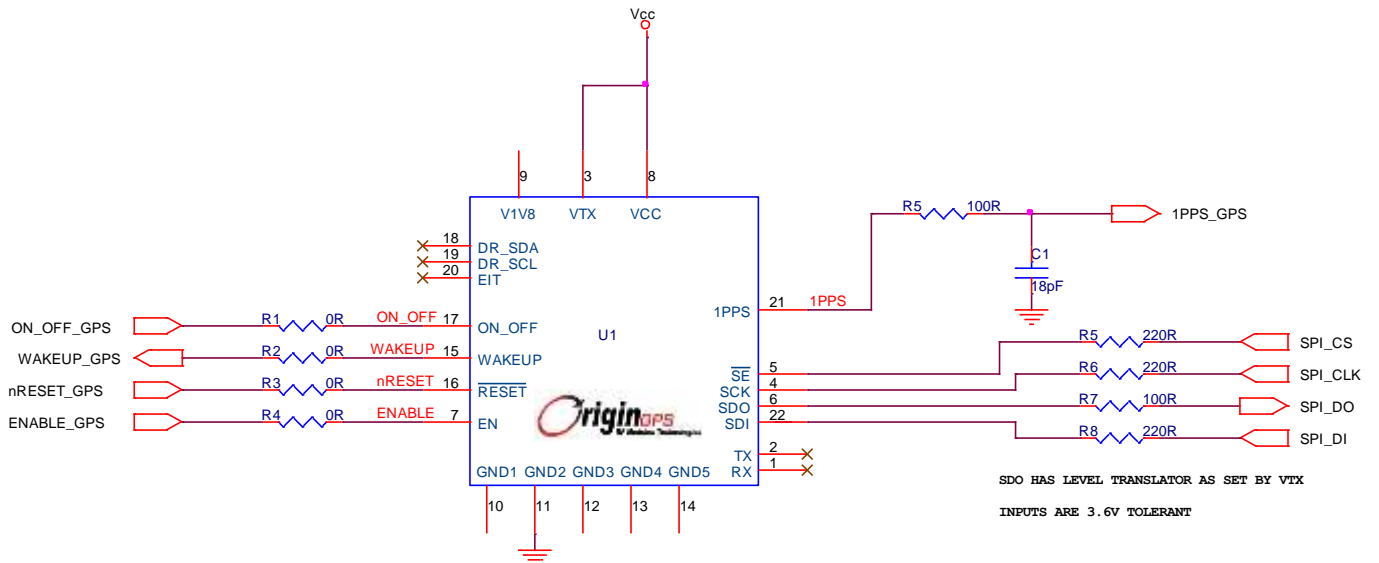

FIGURE 11 – SPI INTERFACE CIRCUIT

17. PCB LAYOUT

17.1. FOOTPRINT

TOP VIEW

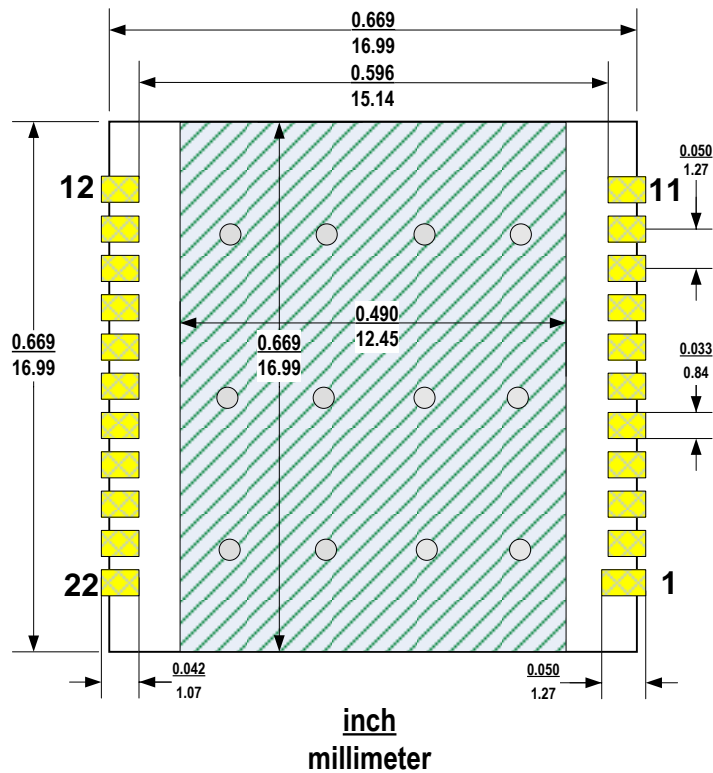

FIGURE 12 – FOOTPRINT



Ground pad at the middle should be connected to main Ground plane by multiple vias.

Ground pad at the middle should be solder masked.

Silk print of module's outline is highly recommended.

17.2. DESIGN RESTRICTIONS

Avoid current loops by connecting single Ground pad to main Ground.

Route the selected Ground pad to main Ground with shortest possible trace or via.

Avoid copper pour on the module side, keeping out the module minimum 6mm from the copper planes, metals planes or enclosures, connectors or LCD screens (Fig. 8-2).

Keep out of minimum 1.6mm from the copper planes under the ORG14XX GPS module (Fig. 8-3).

Keep out of signal or switching power traces and vias under the ORG14XX GPS module.

Signal traces to/from ORG14XX GPS module should have minimum length.

In case of adjacent high speed components, like CPU or memory, high frequency components, like transmitters, clock resonators or oscillators, metal planes, like LCD or battery enclosures, please contact OriginGPS for more precise, application specific recommendations.

17.3. PLACEMENT

Special attention should be paid during GPS module placement and position on host PCB.

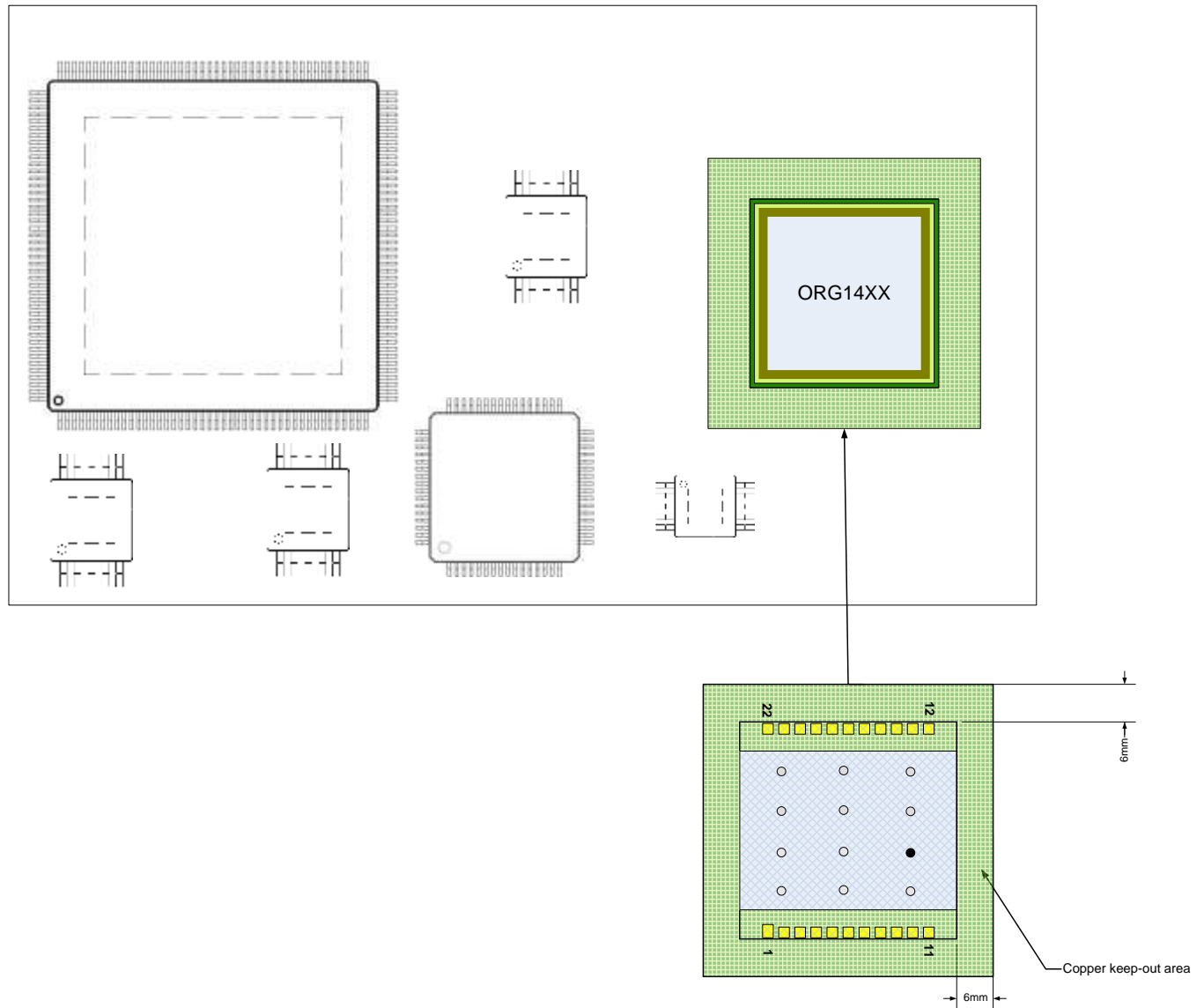

FIGURE 13 – ORG14XX MODULE PLACEMENT

For board specific module position contact OriginGPS.

17.4. PCB STACK UP

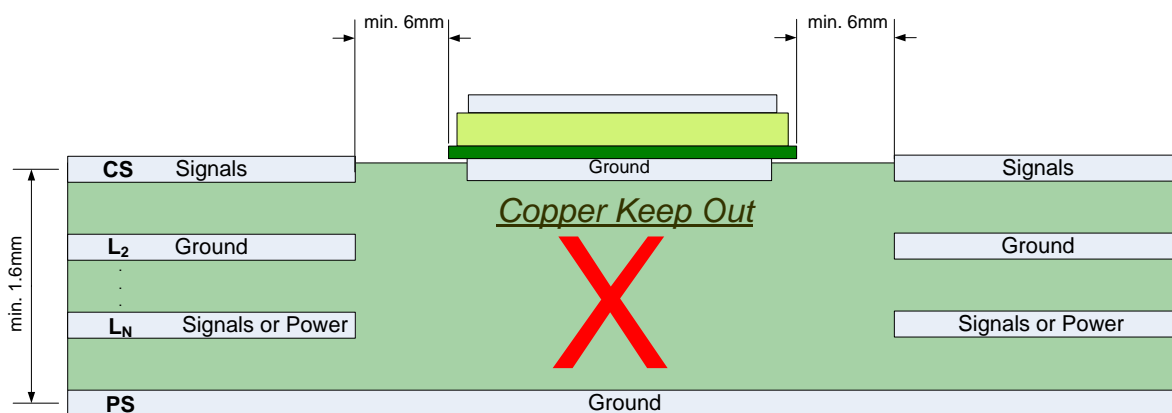

FIGURE 14 – TYPICAL PCB STACK UP

18. OPERATION

When power is first applied, the ORG14XX series module goes into a Hibernate state while integrated RTC starts and internal FSM sequences through to “Ready-to-Start” state.

While in “Ready-to-Start” state, the module awaits a pulse to the ON_OFF input.

The host is not required to control external master nRESET since module’s internal reset circuitry handles detection of application of power.

18.1. STARTING THE MODULE

Module start-up procedure depends upon the chosen ordering option.

	Boot Option 01	Boot Option 02	Boot Option 03
Ordering code	ORG14XX-xx01	ORG14XX-xx02	ORG14XX-xx03
Power On State	Full Power	Hibernate	Hibernate
Host Interface	UART	UART	SPI
Interface settings on power	4,800 bps 8-N-1	4,800 bps 8-N-1	Slave
Data format on power	NMEA	NMEA	NMEA

TABLE 16 – HARDWARE OPTION

01 ordering code:

- ✚ The module has integrated power-up circuit that automatically asserts ON_OFF pulse 1 sec. after FSM indicates “Ready-to-Start” condition.

02 and 03 ordering codes:

- ✚ A pulse on the ON_OFF input will command the module to start.
- ✚ Since integrated RTC startup times are variable, detection of when the module is ready to accept an ON_OFF pulse requires the host to either wait for a fixed interval of 1 sec., or to monitor a pulse on module WAKEUP output that indicates FSM “Ready-to-Start”.
- ✚ Optionally, a pulse on the ON_OFF input can be asserted every second until the module starts by indicating logic high level on WAKEUP output.

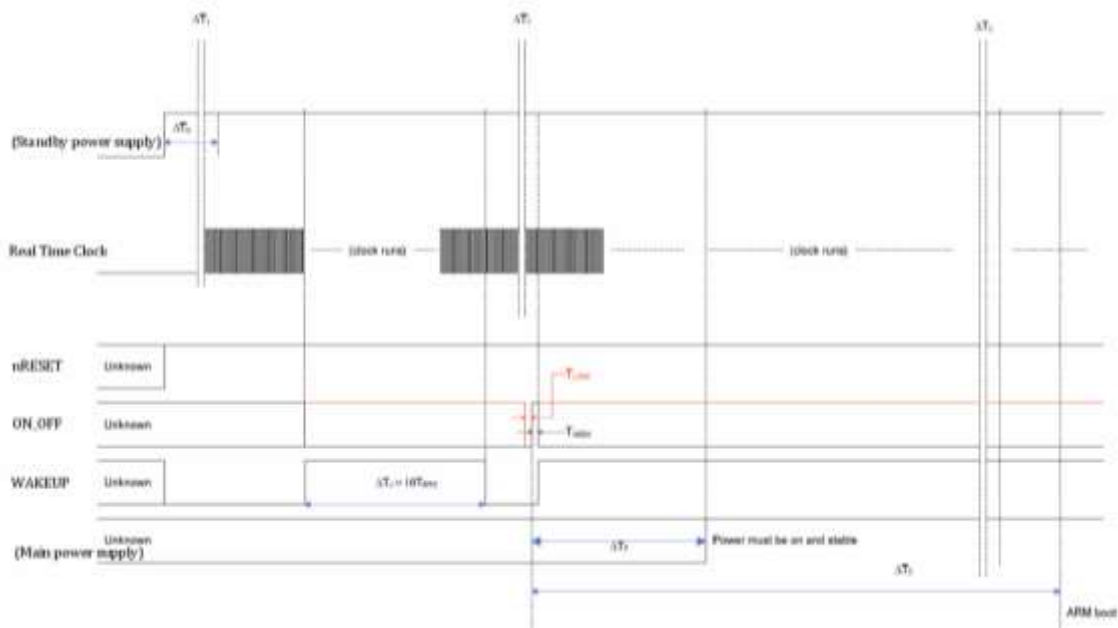

FIGURE 15 – STARTUP TIMING



Symbol	Parameter	Condition	Min	Typ	Max	Units
fRTC	RTC frequency	25°C	-20 ppm	32768	+20 ppm	Hz
tRTC	RTC tick	25°C		30.5176		µs
ΔT1	RTC startup time			300		ms
ΔT0	Power stabilization		6·tRTC+ΔT1	7·tRTC+ΔT1	8·tRTC+ΔT1	µs
ΔT6	WAKEUP pulse	RTC running		10		tRTC
ΔTLOW	ON_OFF low		3			tRTC
ΔTHIGH	ON_OFF high		3			tRTC
ΔT3	Startup sequencing	After ON_OFF		1024		tRTC
-	ON_OFF to WAKEUP high	After ON_OFF		6		tRTC
ΔT5	ON_OFF to ARM start	After ON_OFF		2130		tRTC
ΔT7	Main power source start1	WAKEUP high	0	30	300	tRTC

TABLE 17 – STARTUP TIMING

Note:

1. When power provided through dual supply. Low quiescent current power source (LDO) for Hibernate state, and high efficiency source (DC-DC) for Full Power state. The main power supply should be able to provide current for Full Power state within 1ms after WAKEUP is high.

18.2. VERIFYING THE MODULE HAS STARTED

The ORG14XX module WAKEUP output will go logic high indicating the GPS processor has started. System activity indication depends upon the chosen ordering option.

01 and 02 ordering codes:

- + When active, the module will output NMEA messages at the 4800bps.
- + First NMEA message after power-up is '\$PSRF150,1*3E'.

03 ordering code:

- + Since the module is SPI slave, there is no possible indication of system “ready” through SPI data interface.
- + The host must initiate SPI connection approximately 1 sec. after WAKEUP output goes high.

18.3. SHUTTING DOWN THE MODULE

Transferring the ORG14XX series module into Hibernate state can be initiated in two ways:

- + By a pulse on the ON_OFF input when the ORG14XX module in Full Power state.
- + By serial message MID205 (OSP™) or \$PSRF117 (NMEA).
- + Last message before Hibernate state is '\$PSRF150,1*3F'.

The orderly shutdown may take anywhere from 10ms to 900ms to complete, depending upon operation in progress and messages pending, and hence is dependent upon serial interface speed and controls.

19. SOFTWARE FUNCTIONS

The module supports NMEA-0183 protocol and One Socket Protocol (OSP™).

19.1. NMEA

NMEA is generic ASCII protocol used by general purpose GNSS receivers.

NMEA Output Messages

Message	Description
\$GPGGA	Time, position and fix type data
\$GPGLL1	Latitude, longitude, UTC time of position fix and status
\$GPGSA	GPS receiver operating mode, satellites used in the position solution and DOP values
\$GPGSV	The number of GPS satellites in view, satellite ID, elevation, azimuth and SNR values
\$GPRMC	Time, date, position, course and speed data
\$GPVTG1	Course and speed information relative to the ground
\$GPZDA1	1PPS timing message
\$PSRF150	OK to send data to the module
\$PSRF155	Extended Ephemeris Proprietary Message
\$PSRF156,0x20	ECLM ACK/NACK
\$PSRF156,0x21	ECLM EE Get Age response
\$PSRF156,0x22	ECLM Get SGEE Age response
\$PSRF156,0x23	ECLM Download Initiate Request
\$PSRF156,0x24	ECLM Erase Storage File
\$PSRF156,0x25	ECLM Update File Content
\$PSRF156,0x26	ECLM Request File Content

TABLE 18 – NMEA PROTOCOL OUTPUT MESSAGES

Note:

1. Not transmitted by default, can be enabled by \$PSRF103 command

NMEA Input Messages

Message ID	Message	Description
\$PSRF100	Set Serial Port	Set UART parameters and protocol
\$PSRF101	Navigation Initialization	Parameters required for start using X/Y/Z
\$PSRF103	Query/Rate Control	Query standard NMEA message and/or set output rate
\$PSRF104	LLA Navigation Initialization	Parameters required for start using Lat/Lon/Alt
\$PSRF105	Development Data On/Off	Development Data messages On/Off
\$PSRF106	Select Datum	Selection of an alternative map datum
\$PSRF107	Extended ephemeris proprietary message	
\$PSRF108	Extended ephemeris proprietary message	
\$PSRF110	Extended ephemeris debug	
\$PSRF114,0x16	ECLM start download	
\$PSRF114,0x17	ECLM file size	
\$PSRF114,0x18	ECLM packet data	
\$PSRF114,0x19	ECLM Get EE Age	
\$PSRF114,0x1A	ECLM Get SGEE Age	
\$PSRF114,0x1B	ECLM Host File Content	
\$PSRF114,0x1C	ECLM Host ACK/NACK	
\$PSRF117	System Turn Off	
\$PSRF120	Storage Configuration Setting	

TABLE 19 – NMEA PROTOCOL INPUT MESSAGES



19.2. OSP™

OSP™ is a proprietary extension to SiRF Binary Standard protocol used by SiRF GPS processors.

OSP Binary Output Messages

MID (hex)	MID (dec)	Definition	Sub ID (hex)	Sub ID (dec)	Definition
0 x 02	2	Measured Navigation Data			
0 x 03	3	True Tracker Data			
0 x 04	4	Measured Tracking Data			
0 x 06	6	SW Version			
0 x 07	7	Clock Status			
0 x 08	8	50 BPS Subframe Data			
0 x 09	9	Throughput			
0 x 0A	10	Error ID			
0 x 0B	11	Command Acknowledgement			
0 x 0C	12	Command No Acknowledgement			
0 x 0D	13	Visible List			
0 x 0E	14	Almanac Data			
0 x 0F	15	Ephemeris Data			
0 x 10	16	Test Mode 1			
0 x 12	18	Ok To Send			
0 x 13	19	Navigation Parameters			
0 x 14	20	Test Mode 2			
0 x 1B	27	DGPS Status			
0 x 1C	28	Nav. Lib. Measurement Data			
0 x 1E	30	Nav. Lib. SV State Data			
0 x 1F	31	Nav. Lib. Initialization Data			
0 x FF	255	Development Data			

TABLE 20 – OSP BINARY OUTPUT MESSAGES

OSP Binary Input Messages

MID (hex)	MID (dec)	Definition	Sub ID (hex)	Sub ID (dec)	Definition
0 x 35	53	Advanced Power Management			
0 x 80	128	Initialize Data Source			
0 x 81	129	Switch to NMEA Protocol			
0 x 82	130	Set Almanac (upload)			
0 x 84	132	Software Version (Poll)			
0 x 86	134	Set Main Serial Port			
0 x 87	135	Switch Protocol			
0 x 88	136	Mode Control			
0 x 89	137	DOP Mask			
0 x 8A	138	MID_SET_DGPS_MODE			

0 x 8B	139	Elevation Mask			
0 x 8C	140	Power Mask			
0 x 8D	141	Editing Residual			
0 x 8E	142	Steady-State Detection			
0 x 8F	143	Static Navigation			
0 x 90	144	Poll Clock Status			
0 x 92	146	Poll Almanac			
0 x 93	147	Poll Ephemeris			
0 x 95	149	Set Ephemeris (upload)			
0 x 96	150	Switch Operating Mode			
0 x 97	151	Set Trickle Power Parameters			
0 x 98	152	Poll Navigation Parameters			
0 x A5	165	Set UART Configuration			
0 x A6	166	Set Message Rate			
0 x A7	167	Low Power Acquisition Parameters			
0 x A8	168	MID_POLL_CMD_PARAM			
0 x A9	169	Set Datum			
0 x AA	170	Set SBAS Parameters			
0 x AC	172	MID_DrIn	0 x 01	1	Set DrNavInit
			0 x 02	2	Set DrNavMode
			0 x 03	3	Set GyrFactCal
			0 x 04	4	Set DrSensParam
			0 x 05	5	Poll DrValid
			0 x 06	6	Poll GyrFactCal
			0 x 07	7	Poll DrSensParam
			0 x 13	19	DR Debug Information
0 x AF	175	Send Command String			
0 x B2	178	SIRF_MSG_SSB_TRACKER_IC	0 x 14	20	Patch Storage Control
			0 x 22	34	Patch Memory Load Request
			0 x 26	38	Patch Memory Exit Request
			0 x 28	40	Patch Memory Start Request
			0 x 90	144	Patch Manager Prompt
			0 x 91	145	Patch Manager Ack.
0 x CD	205	Set Generic Software Control	0 x 10	16	Software Commanded OFF
0 x D1	209	MID_QUERY_REQ			
0 x D2	210	MID_POS_REQ			

TABLE 21 – OSP BINARY INPUT MESSAGES

MID (hex)	MID (dec)	Definition	Sub ID (hex)	Sub ID (dec)	Definition
0 x D3	211	MID_SET_AIDING	0 x 01	1	SET_IONO
			0 x 02	2	SET_EPH_CLOCK

			0 x 03	3	SET_ALM
			0 x 04	4	SET_ACQ_ASSIST
			0 x 05	5	SET_RT_INTEG
			0 x 06	6	SET_UTC_MODEL
			0 x 07	7	SET_GPS_TOW_ASSIST
			0 x 08	8	SET_AUX_NAV
			0 x 09	9	SET_AIDING_AVAIL
0 x D4	212	MID_STATUS_REQ	0 x 01	1	EPH_REQ
			0 x 02	2	ALM_REQ
			0 x 03	3	B_EPH_REQ
			0 x 04	4	TIME_FREQ_APPROX_POS_REQ
			0 x 05	5	CH_LOAD_REQ
			0 x 06	6	CLIENT_STATUS_REQ
			0 x 07	7	OSP_REV_REQ
			0 x 08	8	SERIAL_SETTINGS_REQ
0 x D5	213	MID_SESSION_CONTROL_REQ	0 x 01	1	SESSION_OPEN_REQ
			0 x 02	2	SESSION_CLOSE_REQ
0 x D6	214	MID_HW_CONFIG_RESP			
0xD7	215	MID_AIDING_RESP	0 x 01	1	APPROX_MS_POS_RESP
			0 x 02	2	TIME_TX_RESP
			0 x 03	3	FREQ_TX_RESP
			0 x 04	4	SET_NBA_SF1_2_3
			0 x 05	5	SET_NBA_SF4_5
0xD8	216	MID_MSG_ACK_IN	0 x 01	1	ACK_NACK_ERROR
			0 x 02	2	REJECT
0xD9	217		0 x 01	1	SENSOR_ON_OFF
0xDA	218	MID_PWR_MODE_REQ	0 x 00	0	FP_MODE_REQ
			0 x 01	1	APM_REQ
			0 x 03	3	TP_REQ
			0 x 04	4	PTF_REQ
0xDB	219	MID_HW_CTRL_IN	0 x 01	1	VCTCXO
			0 x 02	2	ON_OFF_SIG_CONFIG
0xDC	220	MID_CW_CONTROLLER_REQ	0 x 01	1	CONFIG
			0 x 02	2	EVENT_REG
			0 x 03	3	COMMAND_SCAN
			0 x 04	4	CUSTOM_MON_CONFIG
			0 x 05	5	FFT_NOTCH_SETUP
0xE1	225	MID_SiRFOOutput	0 x 06	6	STATISTICS
			0 x 07	7	Statistics with Aiding

TABLE 22 – OSP BINARY INPUT MESSAGES

MID (hex)	MID (dec)	Definition	Sub ID (hex)	Sub ID (dec)	Definition
0xE8	232	MID_EE_INPUT	0 x 01	1	SSB_EE_SEA_PROVIDE_EPH
			0 x 02	2	SSB_EE_POLL_STATE
			0 x 10	16	SSB_EE_FILE_DOWNLOAD
			0 x 11	17	SSB_EE_QUERY_AGE
			0 x 12	18	SSB_EE_FILE_PART
			0 x 13	19	SSB_EE_DOWNLOAD_TCP
			0 x 14	20	SSB_EE_SET_EPHEMERIS
			0 x 15	21	SSB_EE_FILE_STATUS
			0 x 16	22	ECLM Start Download
			0 x 17	23	ECLM File Size
			0 x 18	24	ECLM Packet Data
			0 x 19	25	Get EE Age
			0 x 1A	26	Get SGEE Age
			0 x 1B	27	ECLM Host File Content
			0 x 1C	28	ECLM Host ACK/NACK
			0 x 1D	29	ECLM Get NVM Header
0 x FD	253	EE_STORAGE_CONTROL			
0 x FE	254	SSB_EE_DISABLE_EE_SECS			

TABLE 23 – OSP BINARY INPUT MESSAGES

20. HANDLING INFORMATION

20.1. PRODUCT PACKAGING AND DELIVERY

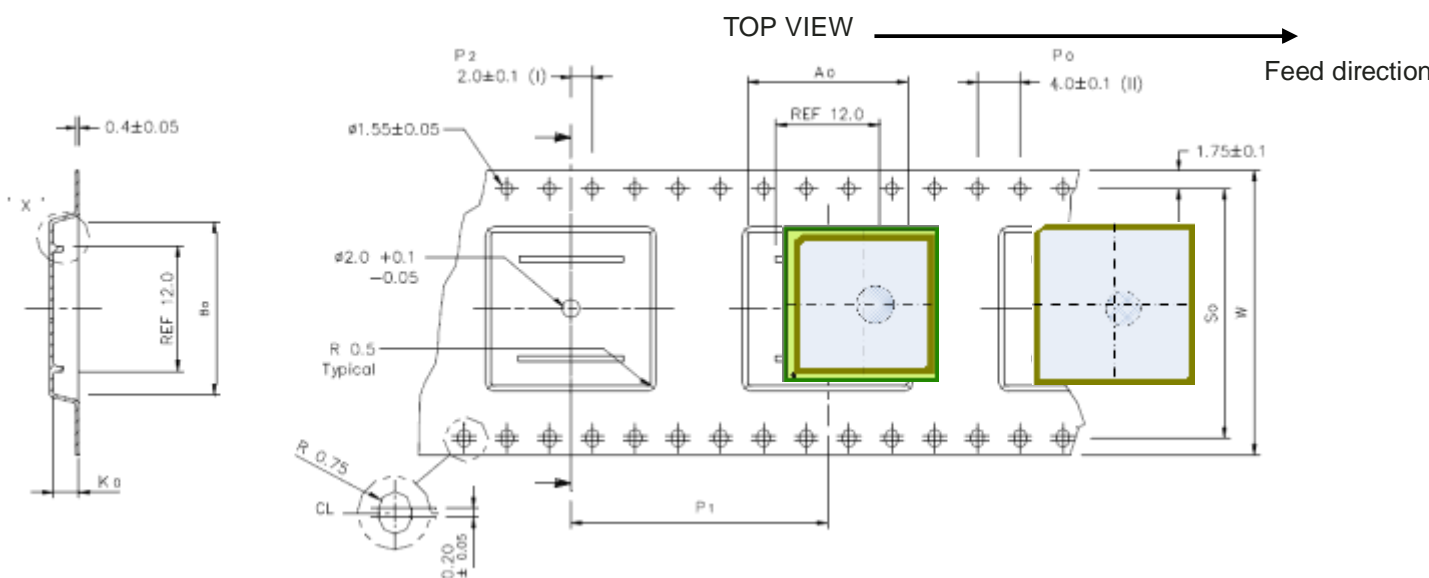
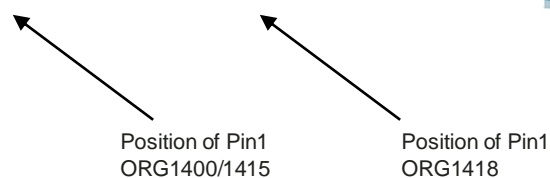

FIGURE 16 – CARRIER

	ORG1400/1415	ORG1418
A0	18.00 ± 0.1	20.50 ± 0.1
B0	18.00 ± 0.1	20.50 ± 0.1
K0	05.70 ± 0.1	05.30 ± 0.1
F	14.20 ± 0.1	14.20 ± 0.1
P1	24.00 ± 0.1	24.00 ± 0.1
S0	28.40 ± 0.1	28.40 ± 0.1
W	32.00 ± 0.3	32.00 ± 0.3

TABLE 24 – CARRIER DIMENSIONS [mm]

Carrier material: Conductive Polystyrene

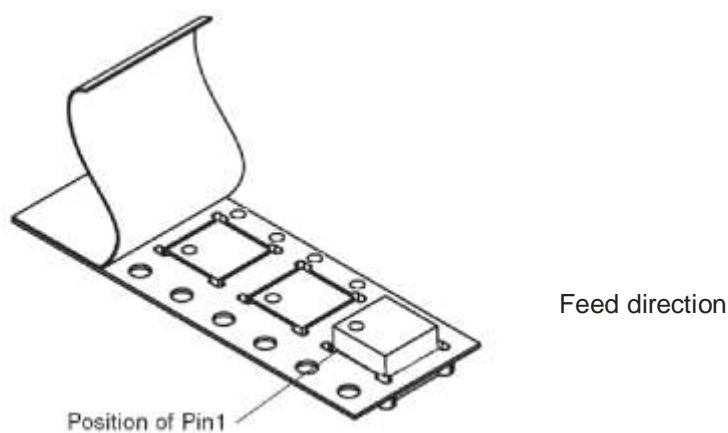

FIGURE 17 – MODULE POSITION

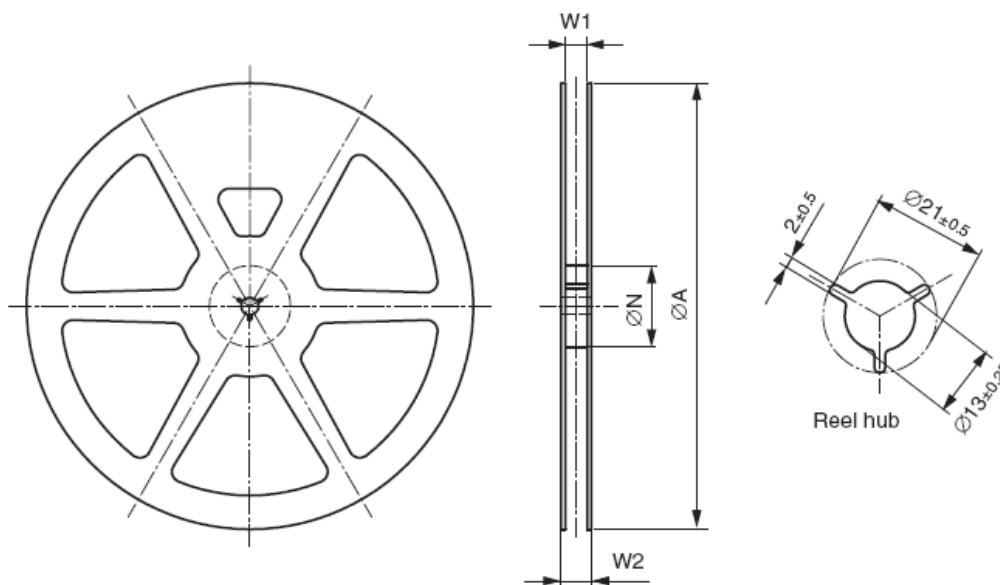

Figure 10-3: Reel

ØA	330.00 ± 0.85
ØN	60.00 ± 0.5
W1	33.00 ± 0.5
W2	39.00 ± 0.5

TABLE 25 – REEL DIMENSIONS [mm]

Reel material: Antistatic Plastic

Units per reel	ORG1400/1415	ORG1418
Minimum	250	200
Maximum	500	400

TABLE 26 – REEL QUANTITY

20.2. MOISTURE SENSITIVITY

The devices are moisture sensitive at MSL 3 according to standard IPC/JEDEC J-STD-033B. The recommended drying process for samples and bulk components is to be done at 125°C for 48 hours.

20.3. ASSEMBLY

The ORG14XX series modules support automatic assembly and reflow soldering processes. Reflow soldering of the ORG14XX series modules on the component side of the motherboard PCB according to standard IPC/JEDEC J-STD-020D for LGA SMD. Suggested solder paste stencil is 5 mil to ensure sufficient solder volume.

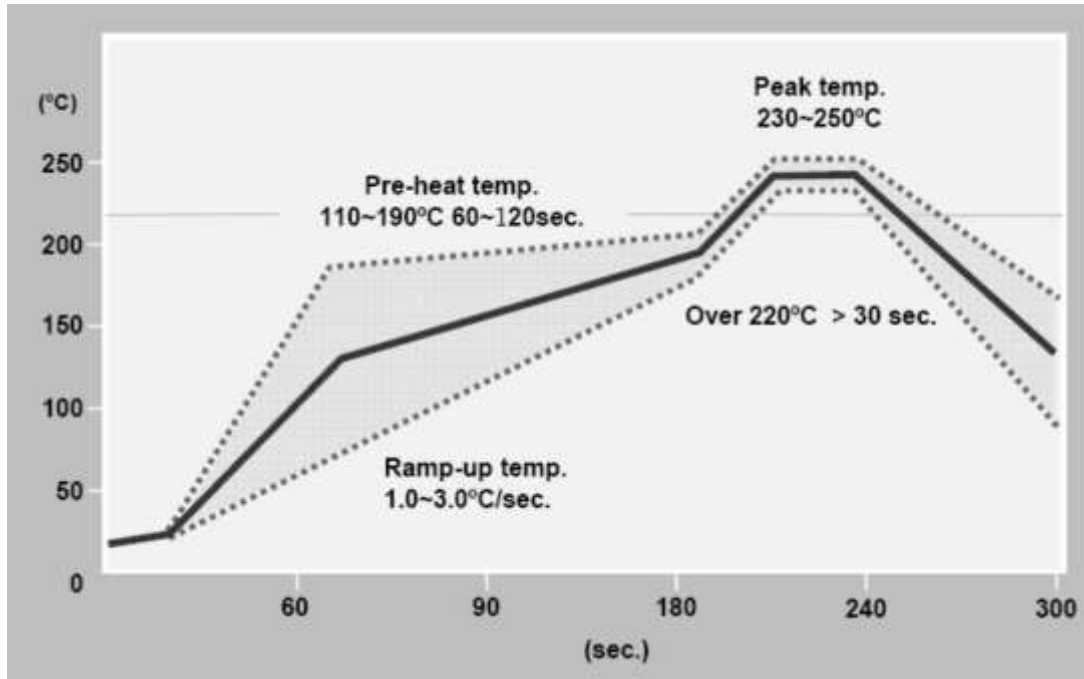

FIGURE 18 – RECOMMENDED SOLDERING PROFILE

Suggested peak reflow temperature is 250°C for 10 sec. for Pb-Free solder paste.
Absolute Maximum reflow temperature is 260°C for 10 sec.

20.4. REWORK

If localized heating is required to rework or repair the ORG14XX series module, precautionary methods are required to avoid exposure to solder reflow temperatures that can result in permanent damage to the device.

20.5. ESD SENSITIVITY

The ORG14XX series module is ESD sensitive device and should be handled with care.

20.6. COMPLIANCES

The following standards are applied on the ORG14XX series modules production:

- + IPC-6011/6012 Class2 for PCB manufacturing
- + IPC-A-600 Class2 for PCB inspection
- + IPC-A-610D Class2 for SMT acceptability

The ORG14XX series modules are being manufactured ISO 9001:2000 accredited facilities.

The ORG14XX series modules are designed and being manufactured and handled to comply with and according with Pb-Free/RoHS Directive 2002/95/EC on the restriction of the use of certain hazardous substances in electrical and electronic equipment.

The ORG14XX series modules comply with the following EMC standards:

- + EU CE EN55022:06+A1(07), Class B
- + US FCC 47CFR Part 15:09, Subpart B, Class B



20.7. SAFETY INFORMATION

Improper handling and use can cause permanent damage to the device.

There is also the possible risk of personal injury from mechanical trauma or shocking hazard.

20.8. DISPOSAL INFORMATION

The product should not be treated as household waste.

For more detailed information about recycling electronic components, please contact your local waste management authority.



21. MECHANICAL SPECIFICATIONS

- + The ORG14XX series modules have advanced miniature packaging and a LGA footprint.
- + The ORG14XX series modules PCB footprint size is 17mm x 17mm.
- + The ORG14XX series modules are surface mount devices packaged on a miniature printed circuit board with a metallic RF enclosure on one side and Microstrip Patch Antenna on top of the shield.
- + There are 22 surface mount connection pads with a base metal of copper and an Electroless Nickel / Immersion Gold (ENIG) finish.
- + The ORG14XX series modules have been designed for automated pick and place assembly and reflow soldering processes.

21.1. ORG1400

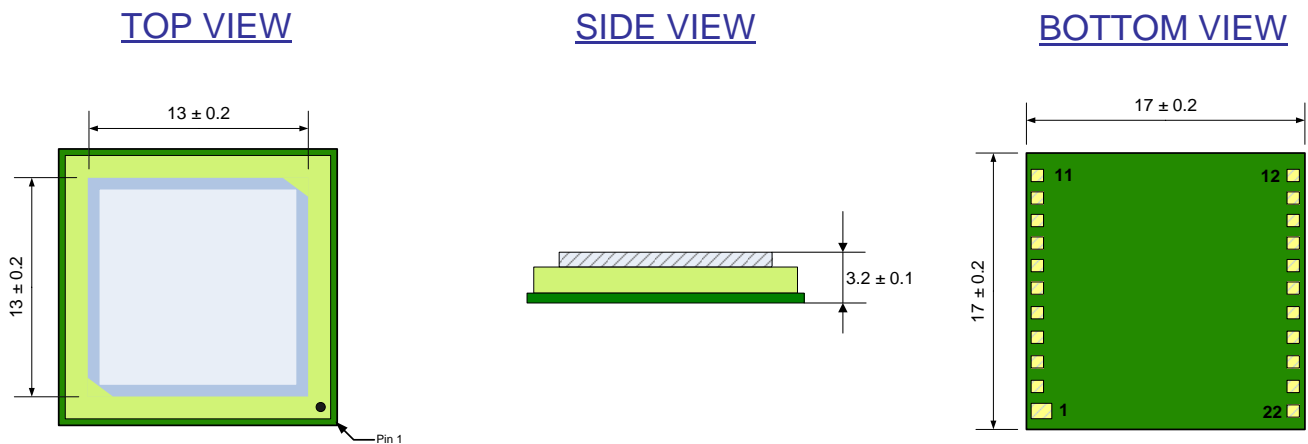

All dimensions are in millimeters

FIGURE 19 – ORG1400 MECHANICAL DRAWING

Dimensions	Length	Width	Height
mm	17.0 ± 0.2	17.0 ± 0.2	3.2 ± 0.1
inch	0.669 ± 0.008	0.669 ± 0.008	0.125 ± 0.004

Weight	
gr	2.2
oz	0.1

TABLE 27 – ORG1400 MECHANICAL INFORMATION

21.2. ORG1415

TOP VIEW

SIDE VIEW

BOTTOM VIEW

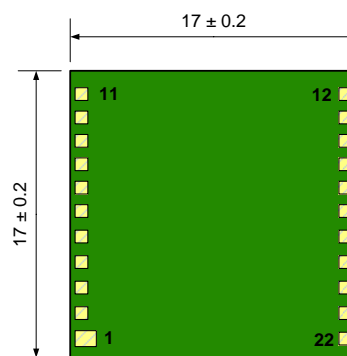
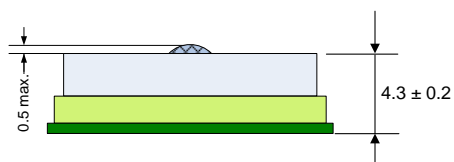
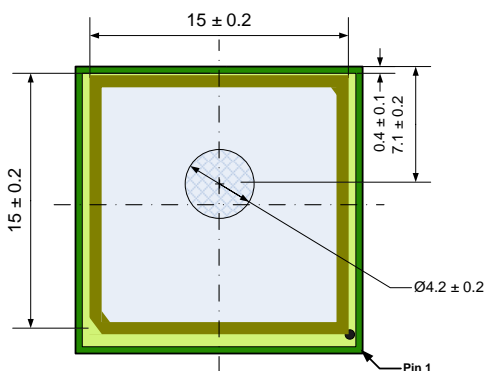

All dimensions are in millimeters

FIGURE 20 – ORG1415 MECHANICAL DRAWING

Dimensions	Length	Width	Height
mm	17.0 ± 0.2	17.0 ± 0.2	4.8 ± 0.2
inch	0.669 ± 0.008	0.669 ± 0.008	0.189 ± 0.008

Weight	
gr	3.5
oz	0.12

TABLE 28 – ORG1415 MECHANICAL INFORMATION

21.3. ORG1418

TOP VIEW

SIDE VIEW

BOTTOM VIEW

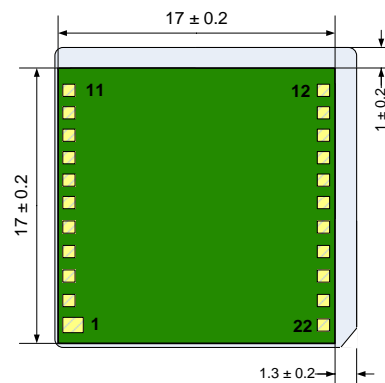
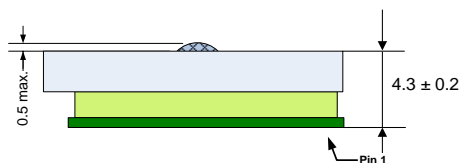
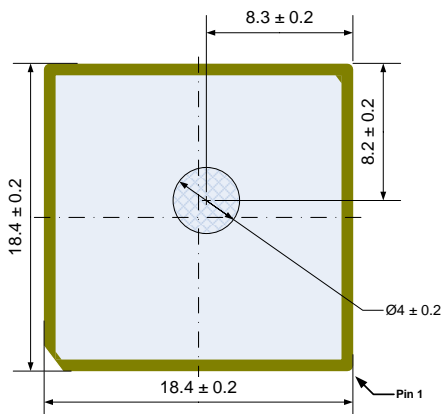

All dimensions are in millimeters

FIGURE 21 – ORG1418 MECHANICAL DRAWING

Dimensions	Length	Width	Height
mm	18.4 ± 0.2	18.4 ± 0.2	4.8 ± 0.2
inch	0.724 ± 0.008	0.724 ± 0.008	0.189 ± 0.008

Weight	
gr	4.75
oz	0.17

TABLE 29 – ORG1418 MECHANICAL INFORMATION

22. ORDERING INFORMATION

ORG 1418 – R 01 – TR

14xx xx xx xxx

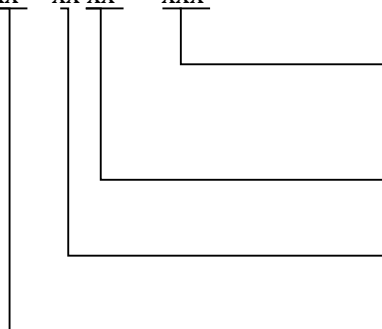

Packaging option {	TR = Tape & Reel
	UAR = Demo Board
	Boot option (Table 12-3)
	Firmware / Hardware option (Table 12-2)
Antenna option (Table 12-1)	

		ORG1400	ORG1415	ORG1418
Ordering code		ORG1400-xxxx	ORG1415-xxxx	ORG1418-xxxx
Average C/N0		40 dB-Hz	45 dB-Hz	48 dB-Hz
PCB outline		17mm x 17mm	17mm x 17mm	17mm x 17mm
Dimensions (typ.)	Length	17 mm	17 mm	18.4 mm
	Width	17 mm	17 mm	18.4 mm
	Thickness	3.2 mm	4.8 mm	4.8 mm

Table 12- 1: Antenna options

		Basic Series	Standard Series	Premium Series
Ordering code		ORG14xx-BCxx	ORG14XX-Rxx	ORG14xx-PMxx
VCC Range		1.8 V	2V – 6V	
TX Output Voltage Max		1.8 V	1.8V – 5V	
Firmware Features	Jammer Remover	✓	✓	✓
	CGEE™ and SGEE™	✓	✓	✓
	ATP™, PTF™, APM™	✓	✓	✓
	SBAS (WAAS/EGNOS)			✓
	MEMS sensors support			✓
	ABP™ support			✓
Boot Option Variants	02	01, 02, 03	01, 02, 03	✓

TABLE 30 – FIRMWARE / HARDWARE OPTIONS

	Boot Option 01	Boot Option 02	Boot Option 03
Ordering code	ORG14xx-xx01	ORG14xx-xx02	ORG14xx-xx03
Power On State	Full Power	Hibernate	Hibernate
Host Interface	UART	UART	SPI
Interface settings on power	4,800 bps	4,800 bps	Slave
Data format on power	NMEA	NMEA	NMEA

23. DESIGN-IN CHECKLIST

Following the Design-In Checklist when developing applications with the ORG14XX series GPS antenna modules it is highly recommended to reduce design risks.

23.1. MODULE SELECTION

ORG14XX series modules have been intentionally designed to allow GPS functionality to be optimally tailored to application specific environment.

Changing between the different modules is easy, due to the same footprint and pin-out.

Does the application demand for ultra low profile GPS antenna module?

Is the GPS module placed in line of sight with GPS satellites?

- Select ORG1400 for ultra-low profile solution.*

Does the application demand for standard positioning and navigation, including indoor tracking?

- Select ORG1415 for high-sensitivity solution.*

Does the application demand for module installation position with limited GPS satellite visibility?

- Select ORG1418 for ultra-sensitivity solution.*

23.2. SCHEMATICS VALIDATION

Check Power Supply Requirements

Is the main power supply voltage (V_{CC}) within the specified range?

- Verify 2.0V to 6.0V. Raw battery voltage source is accepted.*
- ① *The module will shut down when voltage trip below 1.8V.*
- ① *nRESET pad will be internally held in low state.*

Single supply operation required?

- Connect VTX to VCC.*

Is the UART/SPI output buffer power supply voltage (VTX) within the specified range?

- Verify VTX from 1.8V to 5V.*

Is the power source ripple not exceeding maximum allowed?

- ① *Voltage ripple below 50mVpp allowed for frequency between 100KHz and 1MHz.*
- ① *Voltage ripple below 15mVpp allowed for frequency above 1MHz.*

Does the power source capable to handle current consumption requirements?

- ① *Maximum current consumption during acquisition is 45mA.*
- ① *Inrush current during module power up may exceed 60mA.*

Is only single GND pad connected to the main Ground?

Check Communication Interface

Is the UART interface used?

- Connect series ceramic resistor of 100-200Ω and shunt ceramic capacitor of 12-22pF to form low pass filter on GPS TX (pad 2) and GPS RX (pad 1) lines.*
- ① *For SPI host interface options use module with ordering option R03..*

Is the UART/SPI output high logic level voltage VCC tolerant?

- Connect VTX (pad 3) to VCC (pad 8).
- UART voltage level is externally defined by VTX pad.

Check GPIO

Is the Hot or Warm starts needed?

- Connect host output to ON OFF input (pad 17).
- Main VCC is permanently applied. GPS module is hibernated by ON OFF toggle.
- ON OFF input is 1.8-3.6V compatible.

Is module power state indicator required?

- Connect WAKEUP (pad 15) to host input.
- WAKEUP output is LVCMOS 1.8V compatible.
- In Full Power state the WAKEUP is in high state.
- In Hibernate or Standby state the logic level is low.
- Don't drive nRESET input high.
- Don't connect Pull-up to ON_OFF input.
- Don't Pull-up or Pull-down on any of the inputs or outputs if not in use.

23.3. LAYOUT VALIDATION

Is the GPS antenna module placed according to the recommendations?

- Follow the link for module's pin 1 position in OriginGPS provided spreadsheet.

Has the copper keep-out on module's layer been followed?

- Keep out the module minimum 6mm from the metals planes.
- Reduce copper planes on module's side as much as possible.
- For more information refer to Fig. 14.

Has the copper planes keep-out under the module been followed?

- Keep out of minimum 1.6mm from the copper planes under the module.
- For more information refer to Fig. 13.

Is ground paddle under the module connected to main ground plane by multiple vias?

Is ground paddle under the module solder masked?

- Ground paddle under the module is important for EMI immunity of the GPS receiver.
- For more information refer to Figure 13.

Does the silk print of module's footprint outline appear on host PCB?

- Silk print of the module's footprint outline is important for automatic pick and place assembly process and inspection.