



GlobalTop Technology Inc.

EV-Kit User Manual (MT3333 series)

Revision: A02



This document is the exclusive property of GlobalTop Tech Inc. and should not be distributed, reproduced, into any other format without prior permission of GlobalTop Tech Inc. Specifications subject to change without prior notice.

Copyright © 2012 GlobalTop Technology Inc. All Rights Reserved.

No.16 Nan-ke 9th Rd, Science-Based Industrial Park, Tainan, 741, Taiwan, R.O.C.

Tel: +886-6-5051268 / Fax: +886-6-5053381 / Email: sales@gtop-tech.com / Web: www.gtop-tech.com



Version History

Title:	EV-Kit User Manual(MT3333 series)		
Subtitle:	GNSS Module		
Doc Type:	Datasheet		
Revision	Date	Author	Description
A00	2013-03-19	Allen	Preliminary
A01	2013-09-02	Dylan	Add Gms-g6 、Gms-b6
A02	2014-01-13	Delano	Modify web-side link for software tool of GPS viewer



Table of Contents

Version History	2
Table of Contents	3
Caution	4
Packing Contents	5
1. Introduction	6
2. Function Description	7
2.1 Hardware overview:.....	7
3. Operating Instruction	11
3.1 Function Testing	11
3.2 Application for the various RF reception	12
4. Software Usage	13
4.1 System requirement	13
4.2 USB Driver and GPS viewer	13
4.3 Install the USB Driver and Microsoft Framework	14
4.4 GPS Viewer Software usage.....	14
5. RTCM Usage	19
5.1 RTCM hardware setting	19
5.2 RTCM software setting.....	20
6. Trouble-shooting	22
6.1 Problem with Setup	22
6.2 Concerning Poor GNSS Signal	23

Caution

- Global navigation satellite system (GNSS) include GPS+GLONASS and BeiDou GPS+ Beidou-2(COMPASS).
 - ↗ GPS is the property of American Ministry of National Defense.
 - ↗ GLONASS is operated for the Russian government by the Russian Aerospace Defence Forces.
 - ↗ Beidou-2 system, also known as “Compass” has been commercially operational since the end of 2012, and is currently a constellation of 16 satellites ultimately 35 providing worldwide positioning, navigation and timing services to the Asia-Pacific region.

They are fully responsible for the preciseness and maintenance of the system. Any changes they have implemented to the system in the future may enhance or deteriorate the effectiveness and performance of the received GNSS data.
- The GNSS signal might be cut-off or become seriously weakened if you operate EV-kit inside any infrastructures such as buildings, tunnels, or nearby any huge objects and/or obstruction. The kit has not malfunctioned and will operate properly again once it receives clear GNSS signals (works best under open sky).

Packing Contents

- User Manual / Software Application Program
 - CP210X USB Bridge VCP driver
 - GPS Viewer tool with user manual
 - EV-Kit user manual

Note: This information will be delivered by E-mail. Please contact with your dealer.

- USB Cable
- EV-Kit with Main Board 、 GNSS Module Board
- External Antenna (**module : Gmm-g3**)

1. Introduction

The main purpose of this EV-Kit is to simplify the evaluation process to GNSS modules and to help testers operate our products with convenience and ease.

This device can communicate with computer devices via USB, and must be used in conjunction with GPS Viewer software application if you wish to record the all GNSS module data such as satellites' status, time-to-first-fix (TTFF), date and time.

If you would to evaluate RTCM function, it will show you how to connect GNSS simulator with the e EV-kit via RS232 (DB-9 Connector).

The EV-Kit was dividing to 4 series base on the various modules listed below:

With External Antenna (series 1):
Gmm-g3



Built-in Patch Antenna (series 2):
Gms-g9



Built-in chip antenna (series 3):
Gms-g6a



Built-in chip antenna (series 4):
Gms-g6、Gms-b6(Common board)

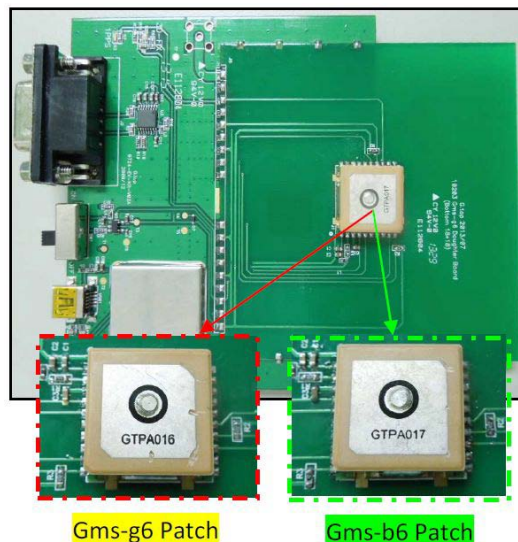

2. Function Description

2.1 Hardware overview:

The EV-Kit device description as the figure show as below.

Compatible Models: (Series 1) Gmm-g3

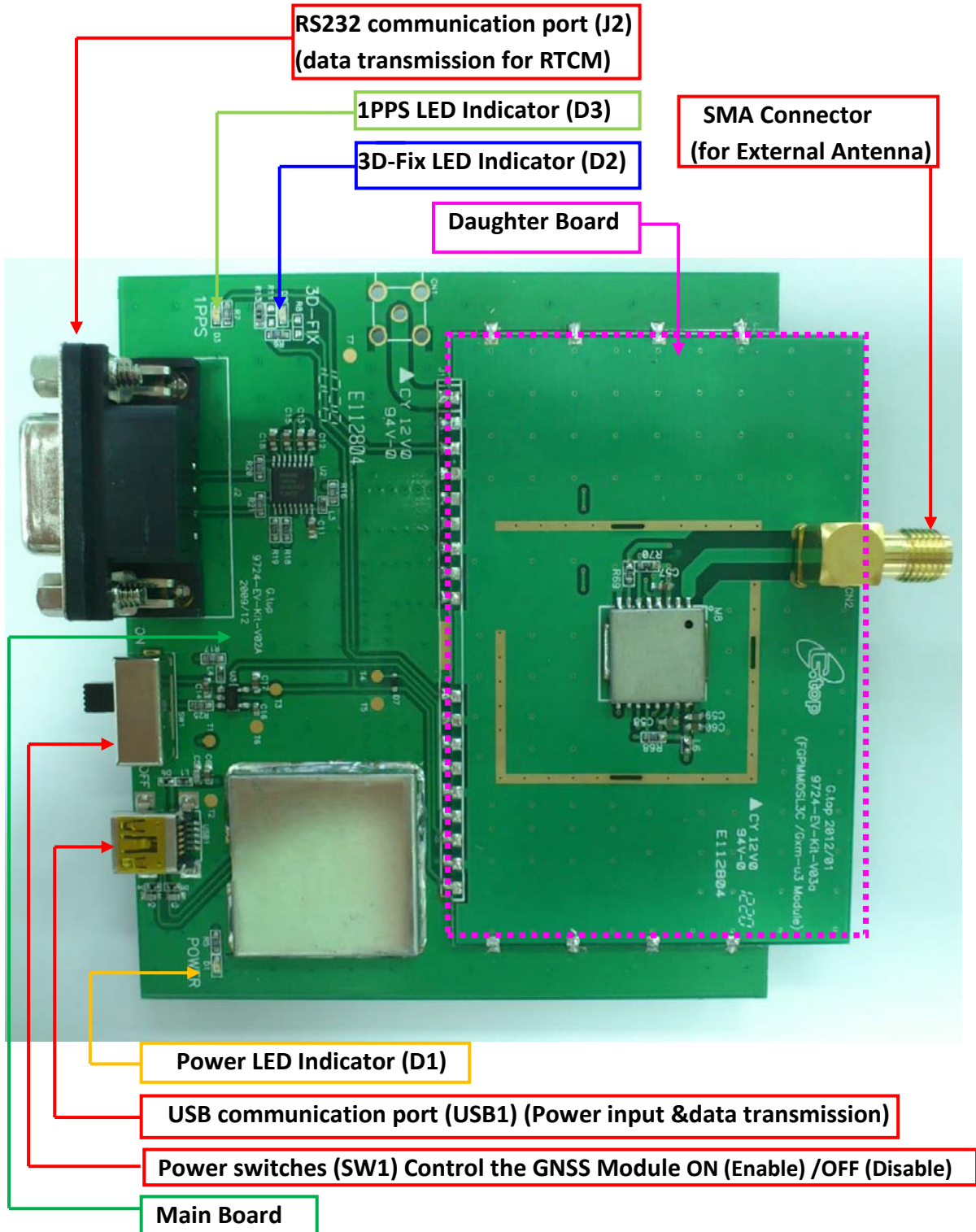

Compatible Model: (Series 2) Gms-g9

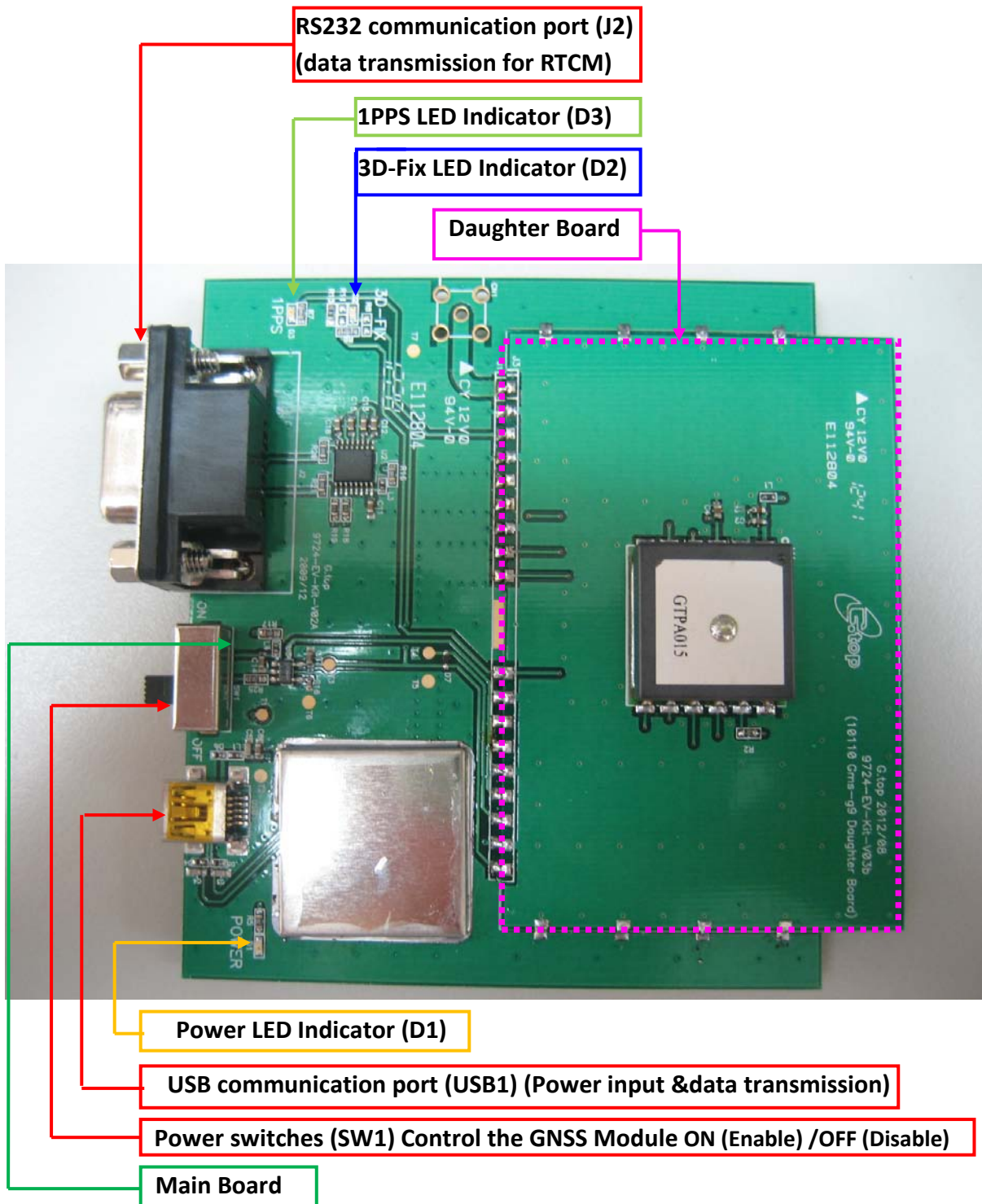

Compatible Model: (series 3) Gms-g6a

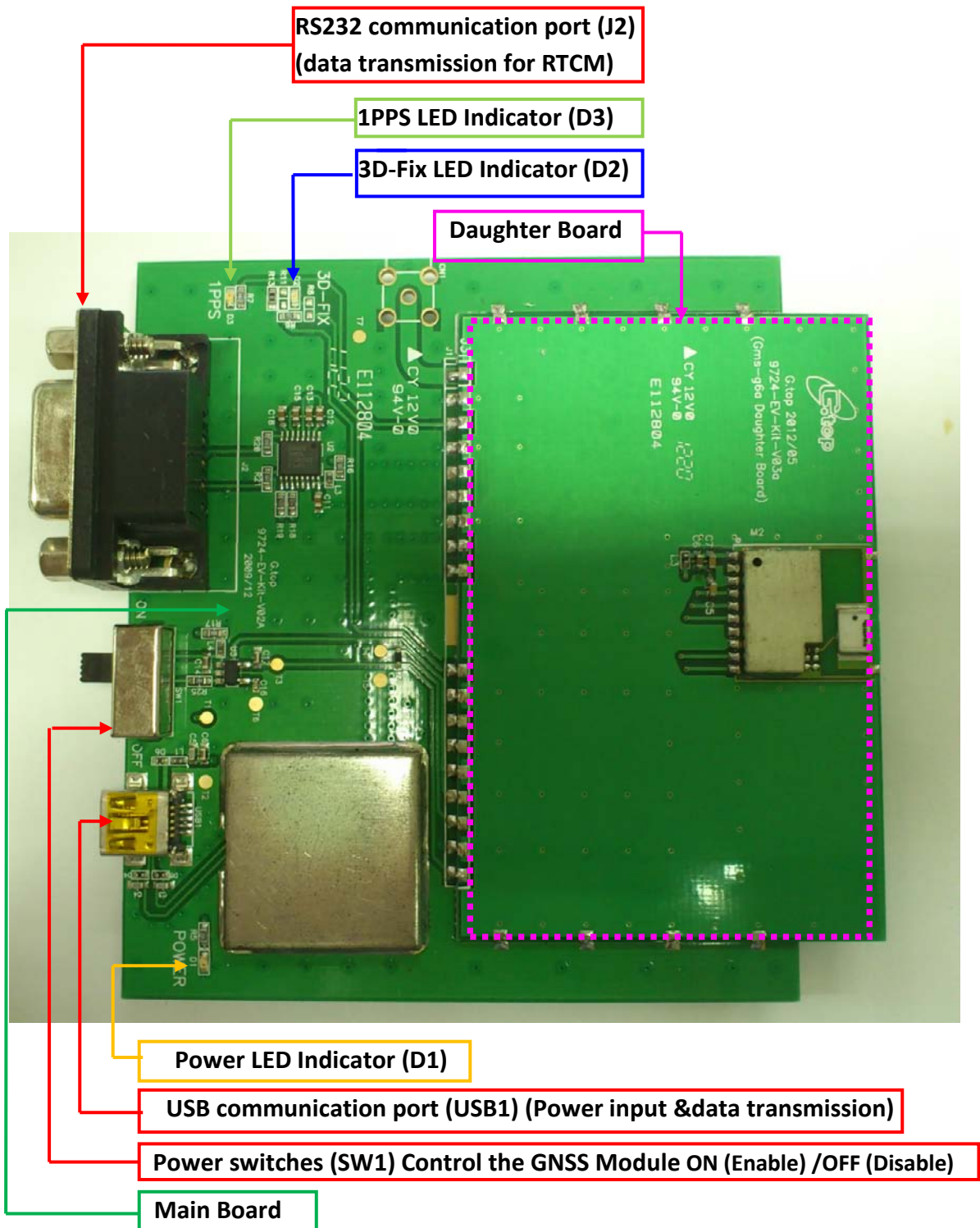

Compatible Model: (series 4)→Gms-g6 、 Gms-b6(Common board)

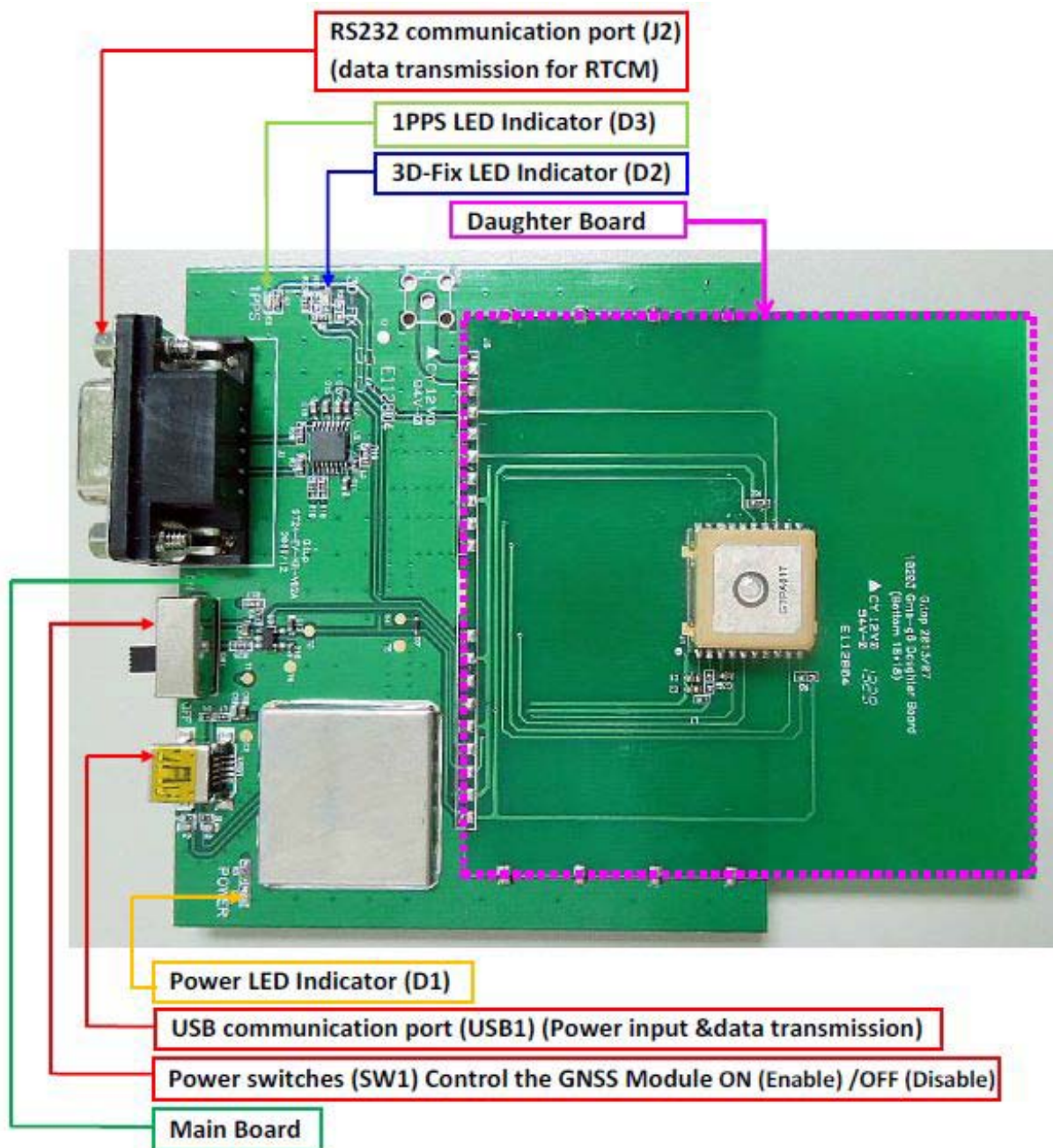

3. Operating Instruction

3.1 Function Testing

➤ Preparation for the power and data communication

Compatible Model: All series

Step 1, connect USB port with PC :

- Connect the USB cable between PC and EV-Kit. The USB cable is used to power the EV-Kit and to transfer communication data with PC. Make sure Power LED Indicator (D1) light is lighted on.

Step 2, Turn on the power for GNSS module :

- The Switch turns on the enable of the LDO to supply the power for GNSS Module. Please refer to figure shown in below.

(1.) Once Power LED Indicator(D1) lights on and main board enable switch(SW1) on, you can find the initial state→
3D Fix LED Indicator (D2) blue is blinking.
1PPS LED Indicator (D3) green is off.

(2.) Once the module getting FIX the stage→
3D Fix LED Indicator (D2) blue is off.
1PPS LED Indicator (D3) green is blinking.

- Both 3D fix and 1PPS status can be re-defined, please contact GlobalTop customization service.

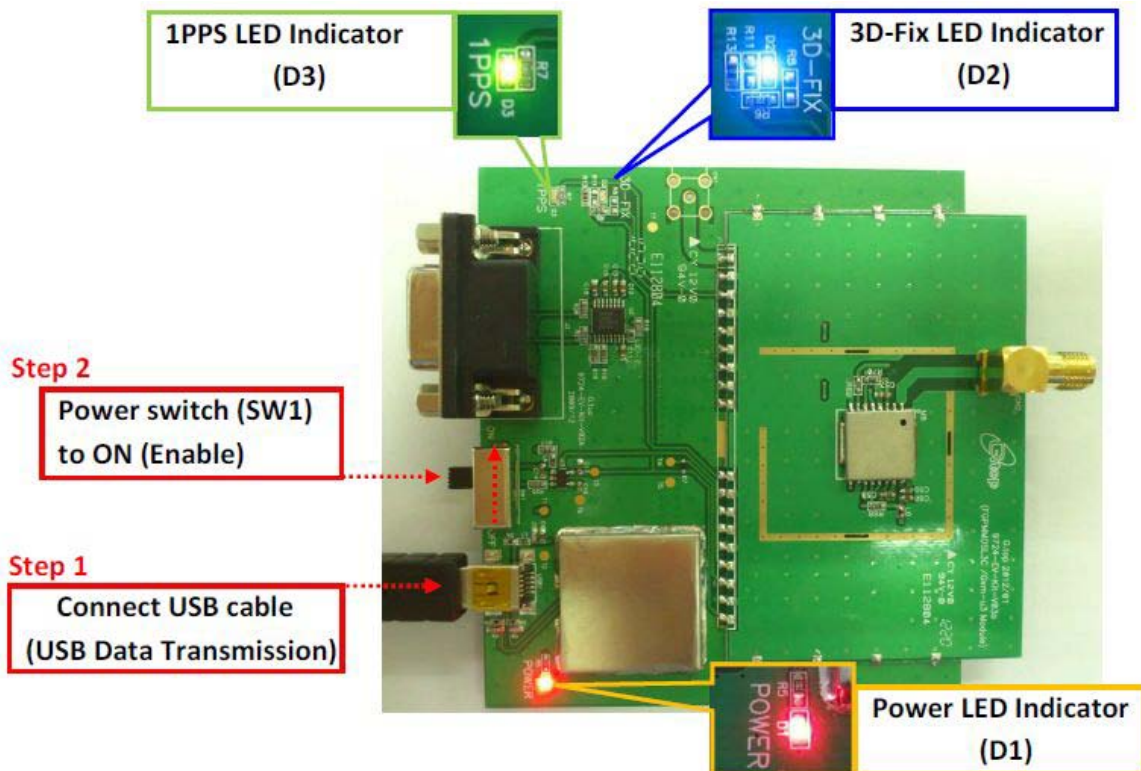

3.2 Application for the various RF reception

a. Using External Antenna with GNSS Module as model below

Compatible Model: (series1) Gmm-g3

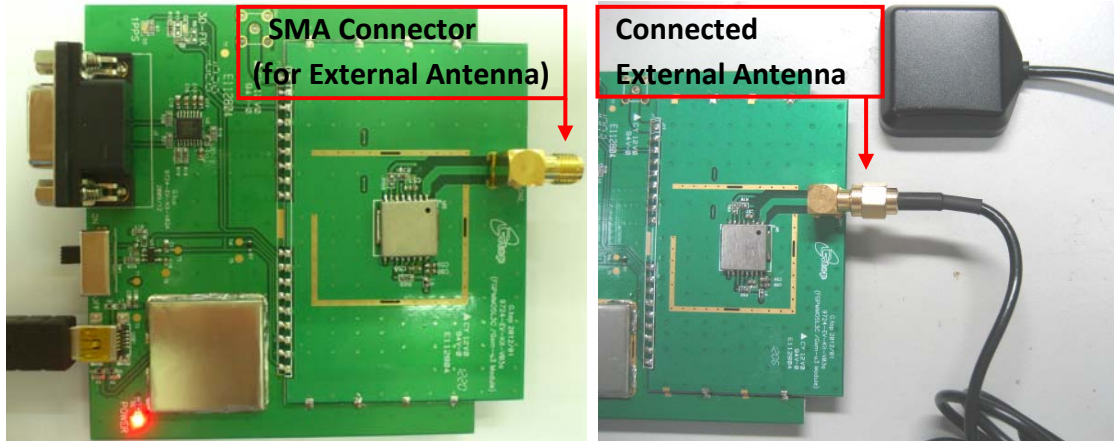

b. Patch Antenna Module below.

Compatible Model: (Series 2) Gms-g9

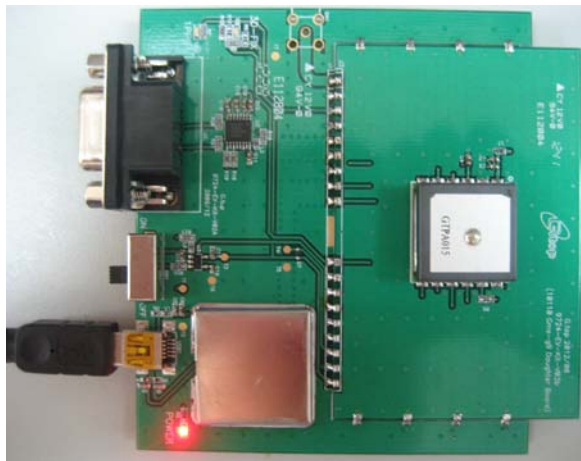

c. Chip Antenna model below.

Compatible Model: (Series 3) Gms-g6a



d. Patch Antenna Module below.

Compatible Model: (Series 4)_Gms-g6、Gms-b6(Common board)

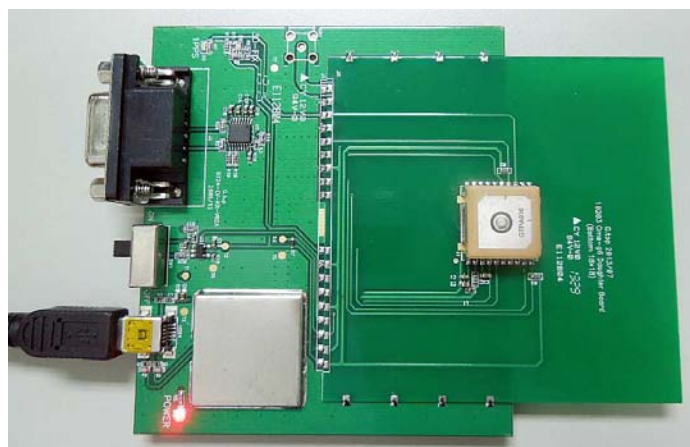

4. Software Usage

4.1 System requirement

PC : IBM, Pentium or above or compatible PC ◦

Operation system : Windows 7/XP/2003/Vista

USB driver: CP210xVCPInstaller.zip

GPS viewer: GPS viewer.exe

4.2 USB Driver and GPS viewer



Please check whether you have the correct USB driver before you proceed to the next step. If incorrect driver is installed, your EV-Kit will not function!

- If you have purchased the EV-Kit for use with GPS Module, please make sure you have **[CP210xVCPInstaller.zip]** installation file in the package, and proceed to the next section: **[4.3 Install the USB Driver]**.

- EV-kit USB Driver Download

From Silicon Labs Web-side (CP210x USB to UART Bridge VCP Drivers)

<http://www.silabs.com/products/mcu/Pages/USBtoUARTBridgeVCPDrivers.aspx>

or From Gtop connect to Silicon Labs Web-side

http://www.gtop-tech.com/en/product/GNSS-EVB-Standalone-Module/GPS_Evaluation_Kit_23.html

- GPS viewer.exe Download

For standalone module evaluation kit:

http://www.gtop-tech.com/en/product/GNSS-EVB-Standalone-Module/GPS_Evaluation_Kit_23.html

For antenna module evaluation kit:

http://www.gtop-tech.com/en/product/GNSS-EVB-Patch-Module/GPS_Evaluation_Kit_22.html

Files Download

- » EV-Kit_User-Manual-A00-(MT3333 series and MT3339 series)
- » Guide to Changing Baud Rate & Update Rate
- » [GlobalTop_GPS_Viewer_v1.8](#)
- » Mini GPS Tool Ver 1.7.1 (for Windows)

4.3 Install the USB Driver and Microsoft Framework

- Please extract the file [CP210xVCPInstaller.zip] and double click [CP210xVCPInstaller.exe] to begin driver installation as the figure show in below.

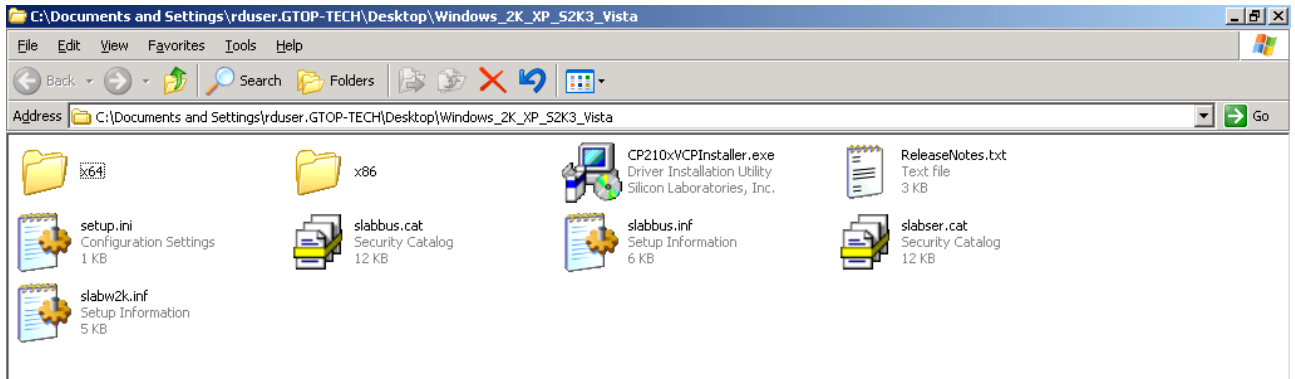

- Click [Install] as the figure show in below.

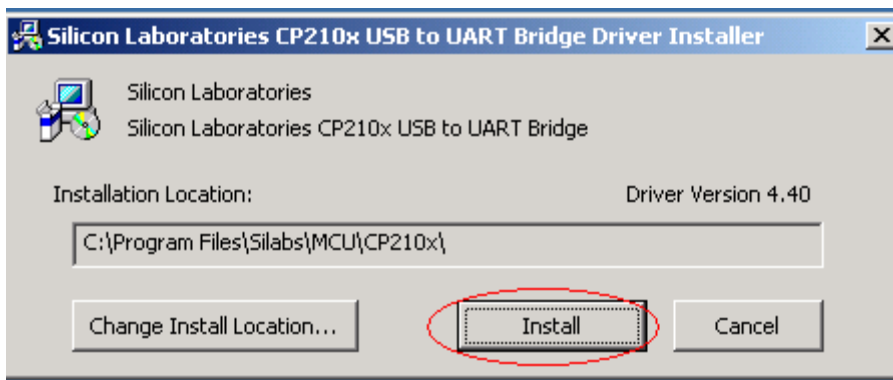

- After the installation is complete, you may need to restart your computer, please follow the instructions on screen to restart your computer.

After the power is on, right click <My Computer>, and select <Manage>, please refer to figure shown in below.

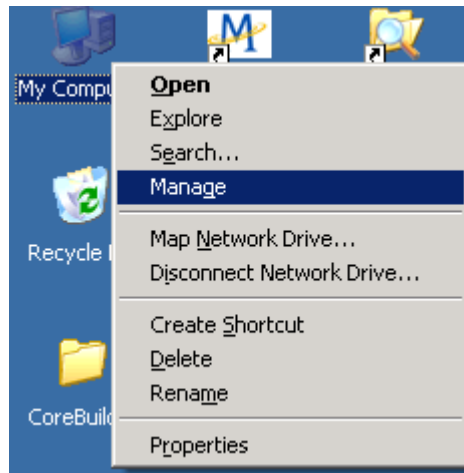

- Left click **<Device Manager>**, and select **<Ports (COM & LPT)>**. Check to see if a device named **<Silicon Labs CP210x USB to UART Bridge (COM#)>** is present. If yes, then EV-Kit is now setup and ready for use, please refer to the figure show in below.

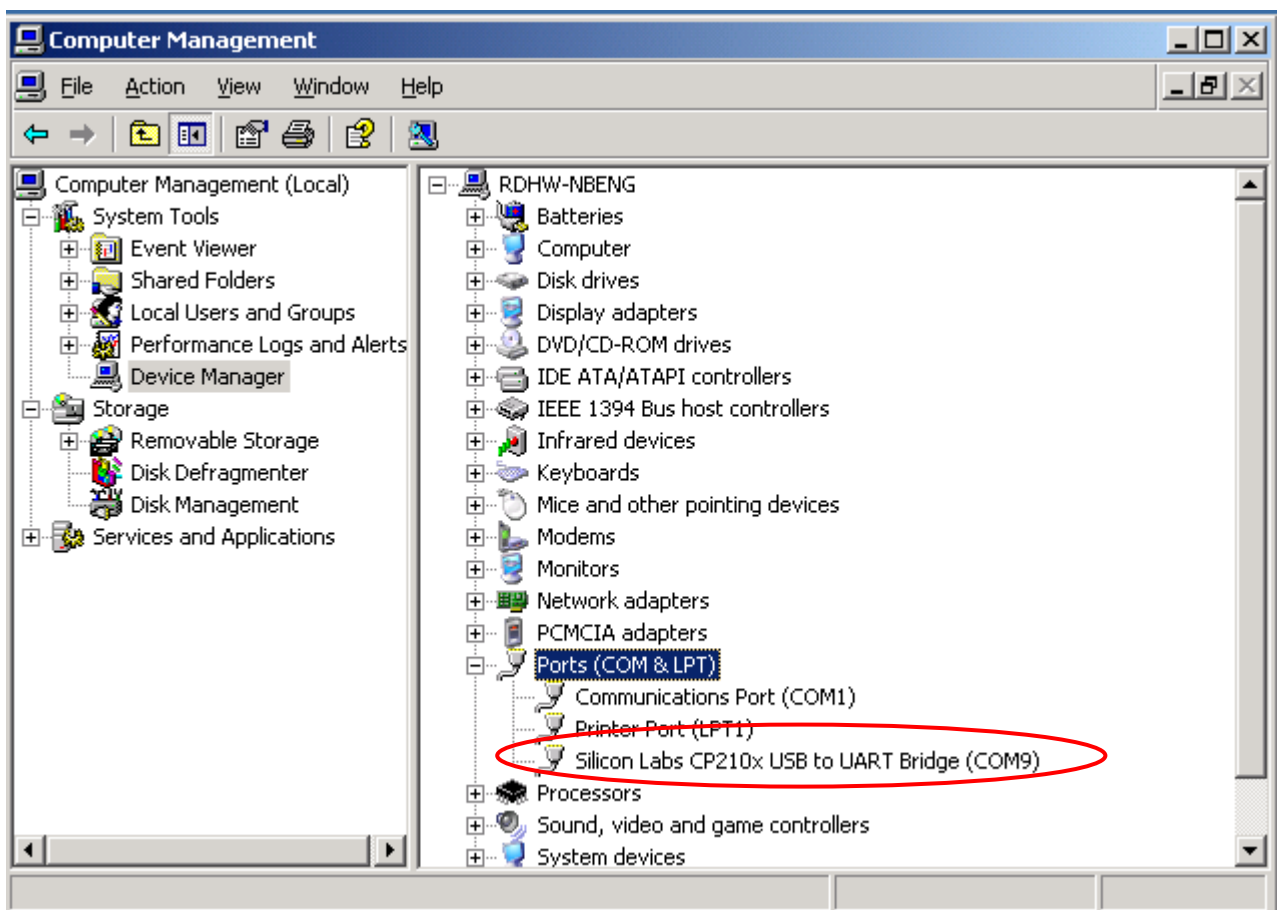

#"represents the virtual COM Port number generated for the USB connection to EV-Kit. This generated COM Port value must match the COM Port value in the program setting for the application to establish proper communication with EV-Kit.



After complete installation, please go forward to [4.4 GPS Viewer Software usage] .

And need to install Microsoft Framework 3.5 version or latest version.

4.4 GPS Viewer Software usage

- **Open GPS viewer software before PC need to install Microsoft Framework 3.5 version or latest version.**
- Double click < **GPS Viewer.exe**> to start the application, the main screen of the program shown in below.
- Select the appropriate <**COM Port**> <**Baud Rate**> and <**Chip**> value. Please refer to figure shown in below.

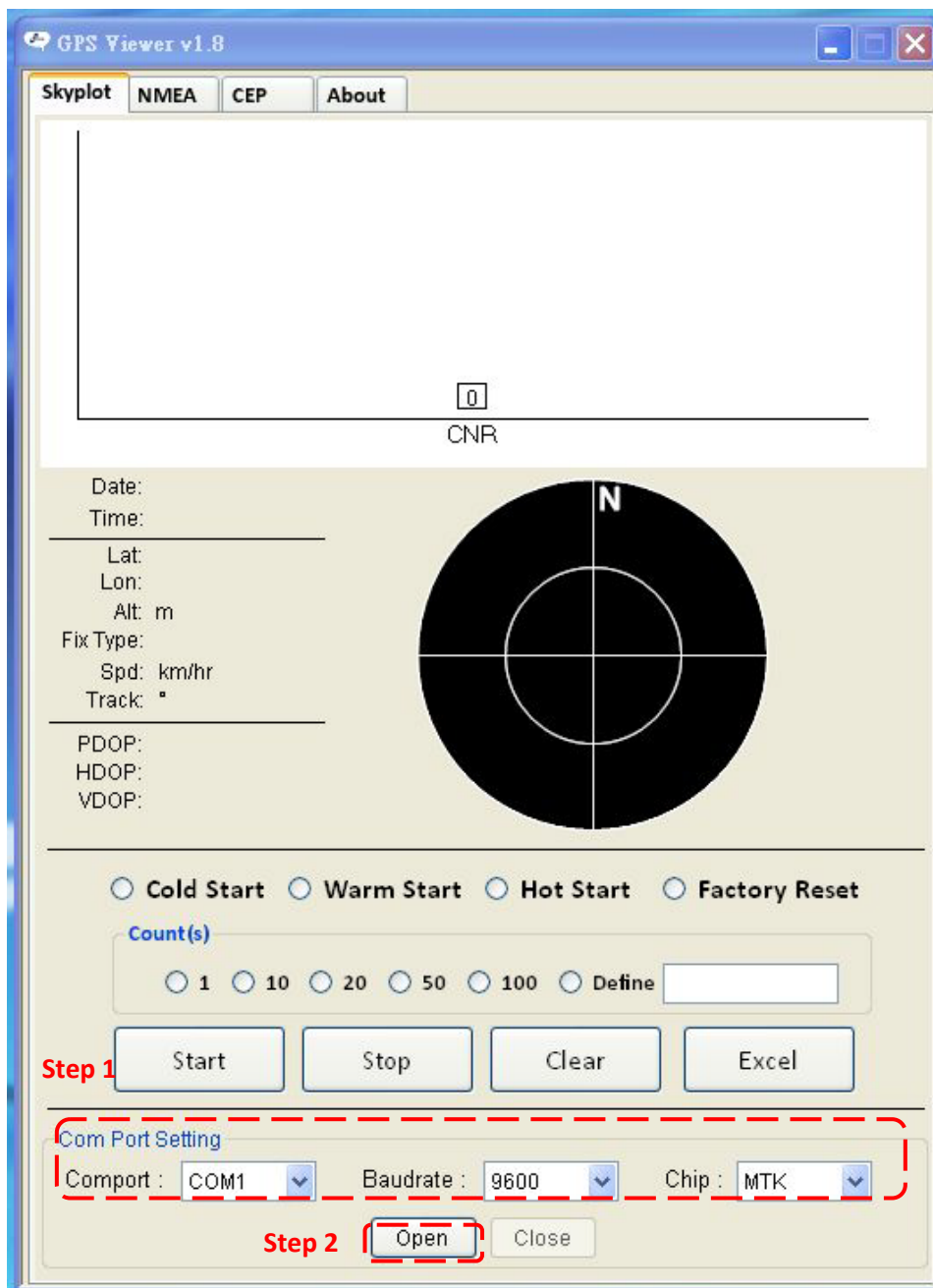

- Finally click <**Open**>. Please refer to figure shown in below.

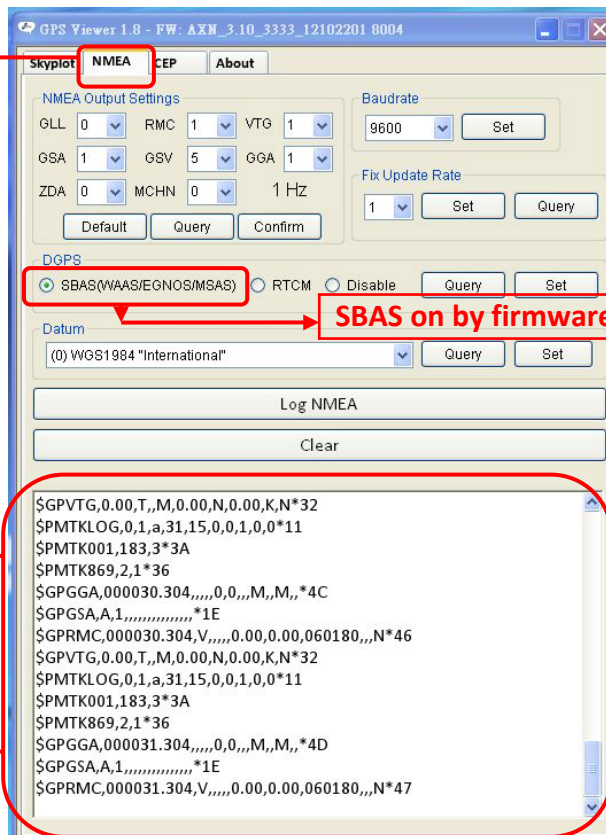
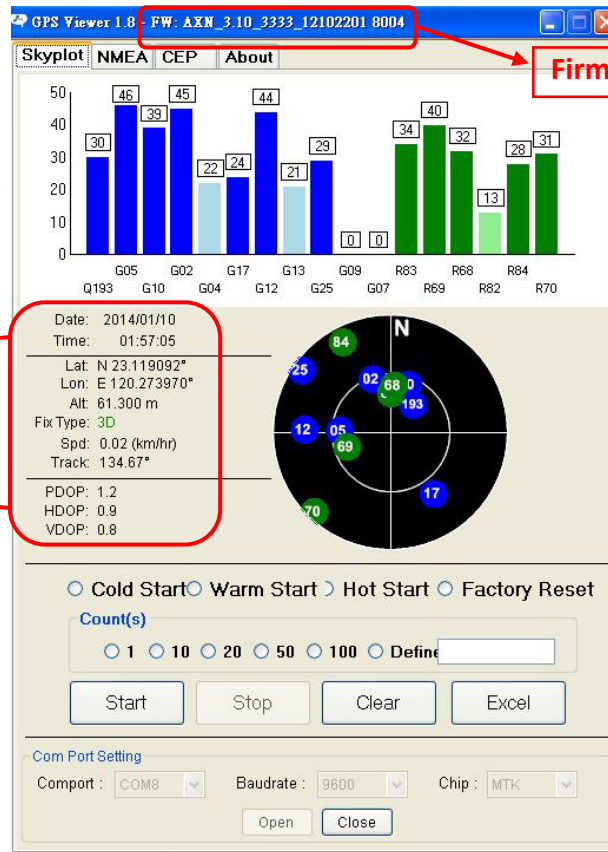

5. RTCM Usage

5.1 RTCM hardware setting

Compatible Model: Gmm-g3、Gms-g9、Gms-g6、Gms-b6

➤ Getting the RTCM data via RS232port :

- Connect the RS232 cable between GNSS simulator and EV-Kit. The RS232 cable is used to the EV-Kit RS232 port (J2) and to GNSS simulator or other RTCM serve as the figure show in below.

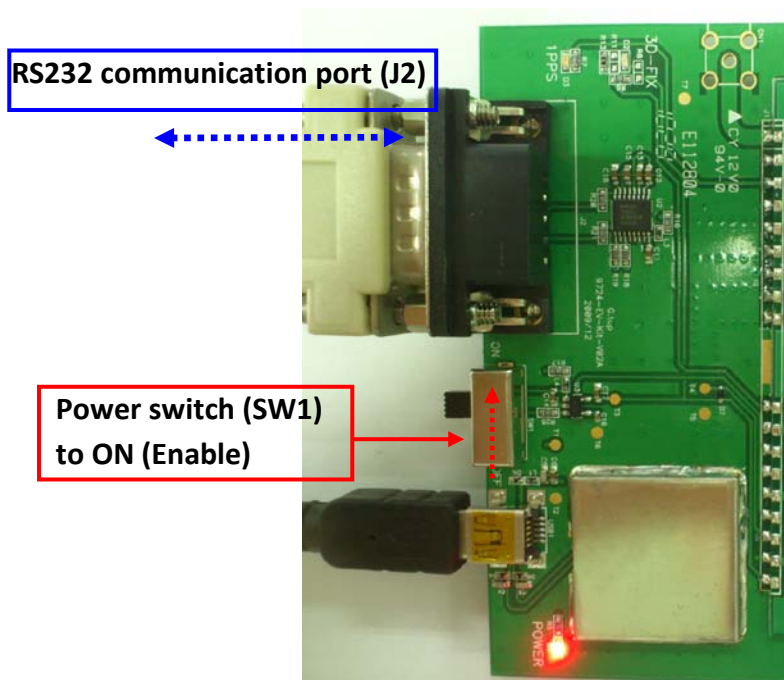

GNSS Simulator Hardware set up as below:

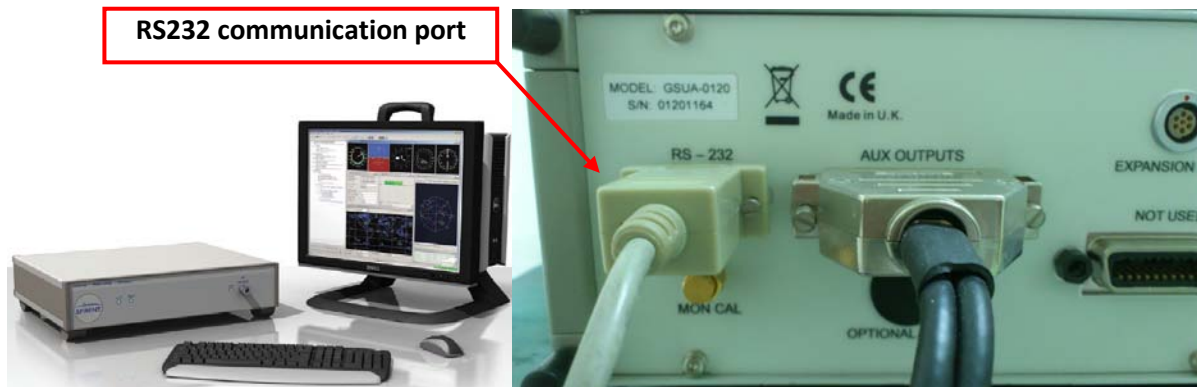

5.2 RTCM software setting

GNSS Simulator software set up as below:

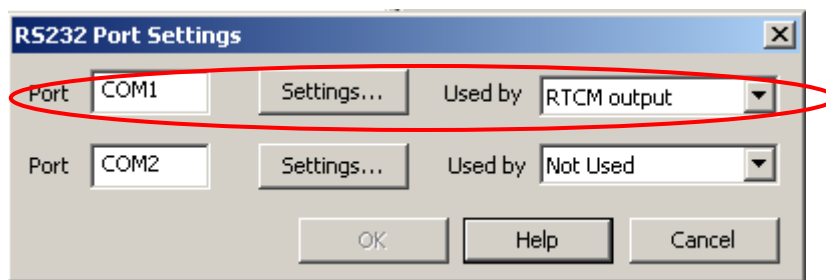
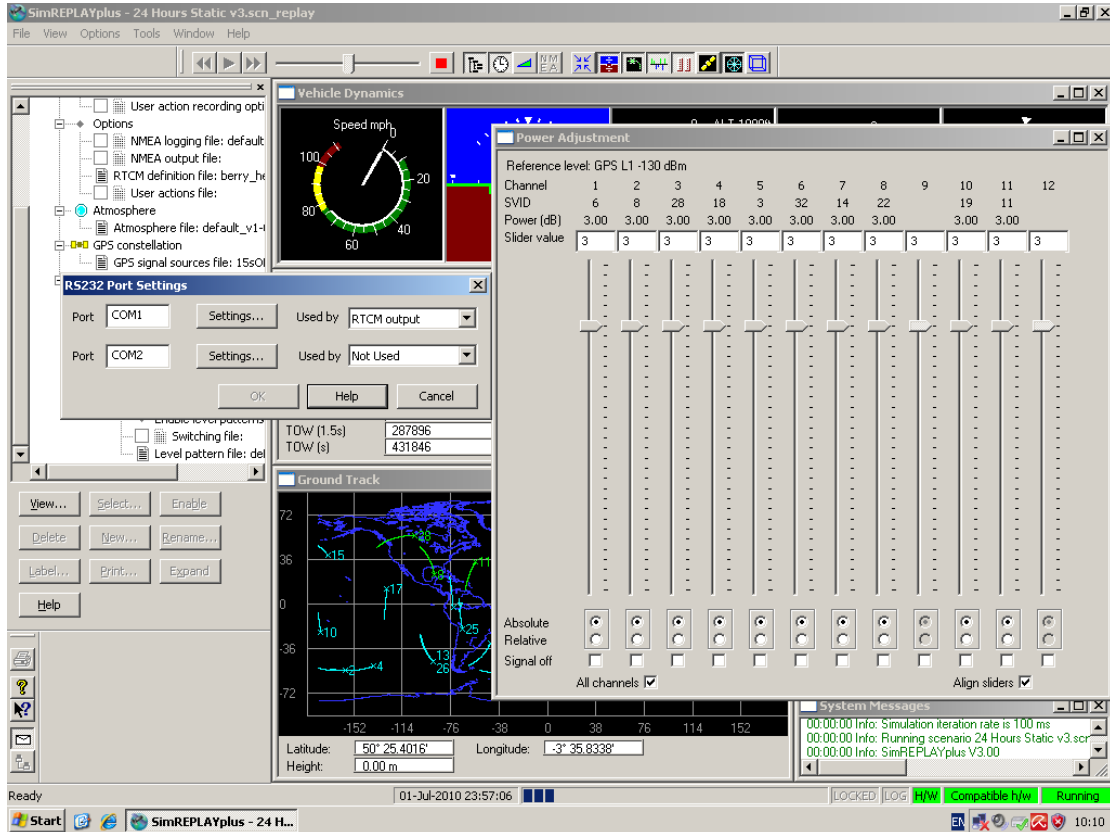

(If customer gets RTCM data from third party, please contact the third party for more details.)

- Please execute GPS viewer Software to check RTCM function of GNSS Module if enable.
- GlobalTop GNSS module has default setting RTCM disable If RTCM enable need, please check firmware feasibility or contact GlobalTop.

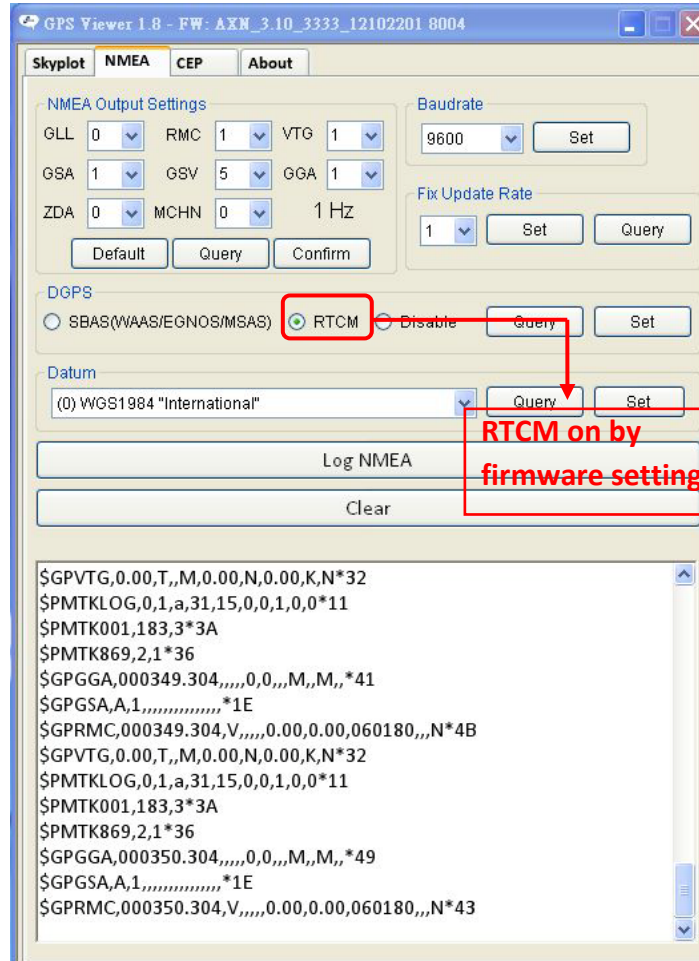

- Please check RTCM function enable by NMEA output sentences as below.

\$GPRMC,064951.000,A,2307.1256,N,12016.4438,E,0.03,165.48,260406,3.05,W,D*2C

\$GPVTG,165.48,T,,M,0.03,N,0.06,K,D*37

D = Differential mode(DGPS)

6. Trouble-shooting

6.1 Problem with Setup

Problem	Possible Cause	Trouble shooting
Cannot find GNSS device	USB was not setup properly.	Check to see if EV-Kit was setup properly, and make sure that the device is receiving enough power through the USB cable (Red LED should light up continuously).
No NMEA data or GNSS signals	(1) USB was not setup properly. (2) COM Port or Baud rate value is incorrect.	(1) Check to see if the USB connector to PC or EV-Kit is tightly connected. (2) Double check to see if the proper COM Port and Baud rate value was selected.
Poor GNSS Signal Reception	(1) If it is used inside a vehicle, the anti-sunscreen film on the windshield may interfere and weaken the GNSS signal reception. (2) When the vehicle is traveling through an area with dense overhead canopy: such as forest, buildings, open tunnels etc.	For both problems, please connect the external antenna to the EV-Kit, and place the antenna on the roof top to improve signal reception.

Note: If the above troubleshooting advice does not solve your problems, please send it back to us for testing and repair.

6.2 Concerning Poor GNSS Signal

It is possible to have GNSS signal reception difficulties under the following situations:

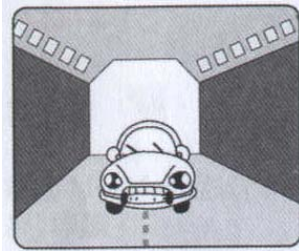

Inside a tunnel, where GNSS signal is blocked.

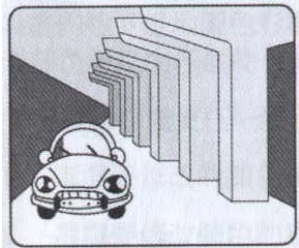

Underneath an infrastructure (like beneath a bridge), where GNSS signal is blocked.

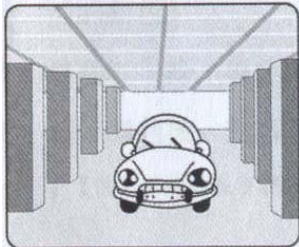

Inside a building, where GNSS signal is blocked.

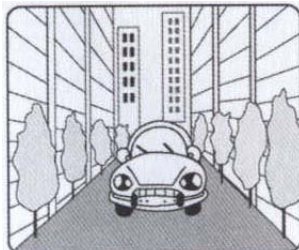

Next to tall buildings, where GNSS signal is weakened.

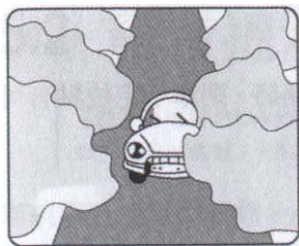

Underneath forests or any other kinds of canopy where GNSS signal is weakened.

- If you use EV-Kit inside a car with anti-sunlight windshield film, the GPS signal will be severely degraded, and may result in no GPS reception.
- GNSS satellite is a property of United States Army. Sometimes they will tune-down the accuracy for unknown reasons. In such cases, the GNSS position may not be as accurate.