

# Cree LED Module LMR4 with EasyWhite™ Technology

**A fast, proven way to realize the promise of LED Lighting**

## Data Sheet

Cree LED Modules provide a simple solution for lighting designers and manufacturers to adopt best-in-class LED lighting from Cree. The LMR series continues Cree's history of innovation in LEDs for lighting applications and provides a comprehensive solution for LED light sources.

This versatile LED lighting module allows design flexibility with a fully integrated, small form factor design that is also drop-in compatible with the LMR4 Cree TrueWhite® Technology version that provides higher color quality. The Cree LED Module LMR4 EasyWhite is the ideal choice for general indoor and outdoor lighting applications that require an LED solution with excellent color consistency. The compact module form factor is a benefit to lighting manufacturers seeking a simple solution to adopt LED lighting or cost-effectively expand their existing LED-lighting product portfolio.

## FEATURES

- Comprehensive solution with driver electronics, optics and core thermals
- 700 lm @ 2700, 3000, 3500 and 4000 K CCT
- Supports dimming to 5%
- Designed to last at least 35,000 hours at L70
- Versatile form factor
- Cree IES LM-80 data in support of U. S. DOE ENERGY STAR® qualification
- The LMR4 (120 V) is UL-recognized and California Title 24-compliant, and the LMR4 (230 V) complies with multiple international standards



## Characteristics

The following table provides several base order codes for the Cree LED module LMR4, as well as a description of the order-code nomenclature.

Color	CCT*	Nominal Luminous Flux (lm)	CRI	Input Power	Input Voltage/Freq	Power Factor	Order Code
Neutral White	4000 K	700	80	12 W	120 V/60 Hz	>.80	LMR040-0700-40F8-10100EW
					230 V/50 Hz	>.90	LMR040-0700-40F8-20100EW
Warm White	3500 K	700	80	12 W	120 V/60 Hz	>.80	LMR040-0700-35F8-10100EW
					230 V/50 Hz	>.90	LMR040-0700-35F8-20100EW
Warm White	3000 K	700	80	12 W	120 V/60 Hz	>.80	LMR040-0700-30F8-10100EW
					230 V/50 Hz	>.90	LMR040-0700-30F8-20100EW
Warm White	2700 K	700	80	12 W	120 V/60 Hz	>.80	LMR040-0700-27F8-10100EW
					230 V/50 Hz	>.90	LMR040-0700-27F8-20100EW

\* Refer to section below on chromaticity for more details

Note: Cree maintains a tolerance of +/- 7% on flux and power measurements

## Form Factor

The Cree LED module LMR4 is constructed with a durable machined aluminum housing and comes complete with an integrated thermal management system. This system conducts heat away from LEDs and transfers it to the mounting plate junction, providing luminaire designers with the flexibility to further optimize their thermal design.

Form factor and measurements are shown below and additional details are also available by downloading the STEP file from [www.cree.com/modules](http://www.cree.com/modules). The standard product configuration consists of the module with the mounting plate attached. A custom fit heat sink is also available and can be ordered separately in units of 10 (part number LMR040-HS00-0000-0000010).

The weight of the module with mounting plate is approximately 250 grams and 150 grams for the heat sink.

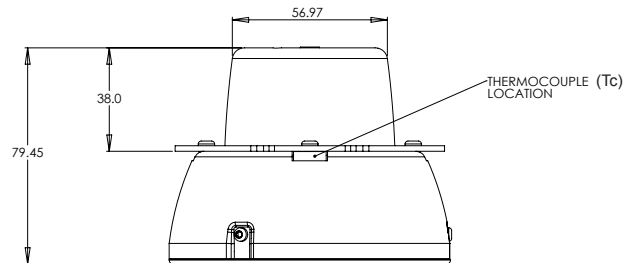
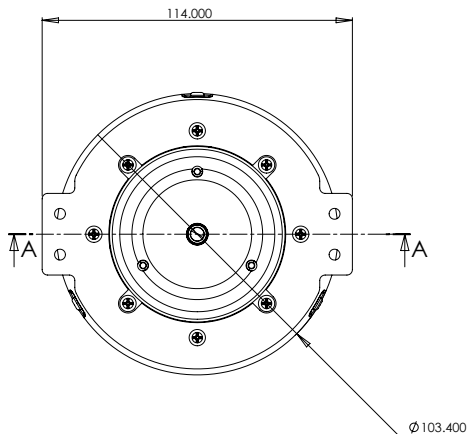



Operating temperature of the Cree LED Module LMR4 is between 0 °C and 50 °C. The lifetime and performance estimates described in this document apply only if the product's Thermal Management Guidelines (below) are adhered to and no modifications are made except as described in this document.

The LED module is flexible; use of the detachable mounting plate or optional heat sink depends on the design requirements. Secondary optics may be added to the module diffuser and lens but will likely reduce light output and could also alter the color characteristics of the final luminaire design.

## Thermal Management Guidelines

The Cree LED module LMR4 is designed to perform in a variety of environments; however, the LED module lifetime is highly dependent upon the operating temperature. To achieve lifetime and performance estimates, and maintain the warranty, the final design cannot exceed 70 degrees Celsius at thermal equilibrium, based on the thermocouple (Tc) location shown in the Form Factor section above.

## Photometry

The following photometry results are based on independent testing.

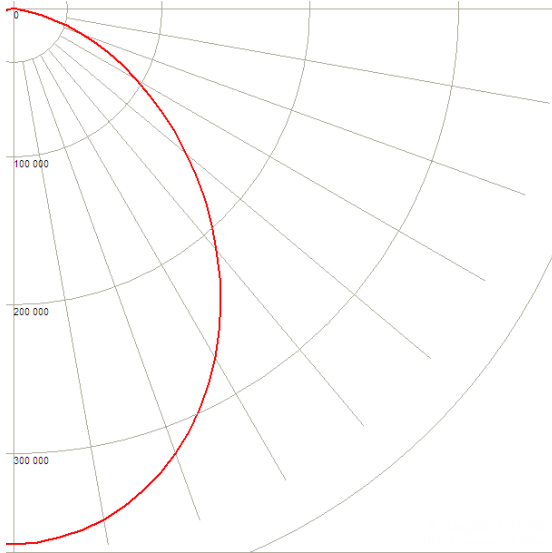

**Intensity (Candlepower)  
Summary**

Angle	Mean CP
0	365.33
5	362.08
15	340.77
25	300.22
35	245.59
45	184.32
55	124.33
65	71.01
75	37.00
85	27.62
90	0.10

**Zonal Lumens Summary**

Zone	Lumens	%Lamp	%Fixt
0-30	242.9	35%	35%
0-40	381.5	55%	55%
0-60	607.6	87%	87%
0-90	700	100%	100%

## Chromaticity

The Cree LED Module LMR4 provides high color consistency around the specified color temperature. Individual LEDs are tested and matched in order to meet the designed chromaticity specification, defined by the following bounding coordinates.

EasyWhite Color Temperatures - 4-Step			
Code	CCT	x	y
40F	4000 K	0.3744	0.3685
		0.3782	0.3837
		0.3912	0.3917
		0.3863	0.3758
35F	3500 K	0.3981	0.3800
		0.4040	0.3966
		0.4186	0.4037
		0.4116	0.3865
30F	3000 K	0.4242	0.3919
		0.4322	0.4096
		0.4449	0.4141
		0.4359	0.3960
27F	2700 K	0.4586	0.4203
		0.4684	0.4164
		0.4569	0.4000
		0.4473	0.4037

## Cree EasyWhite Color Temperatures Plotted on the 1931 CIE Curve

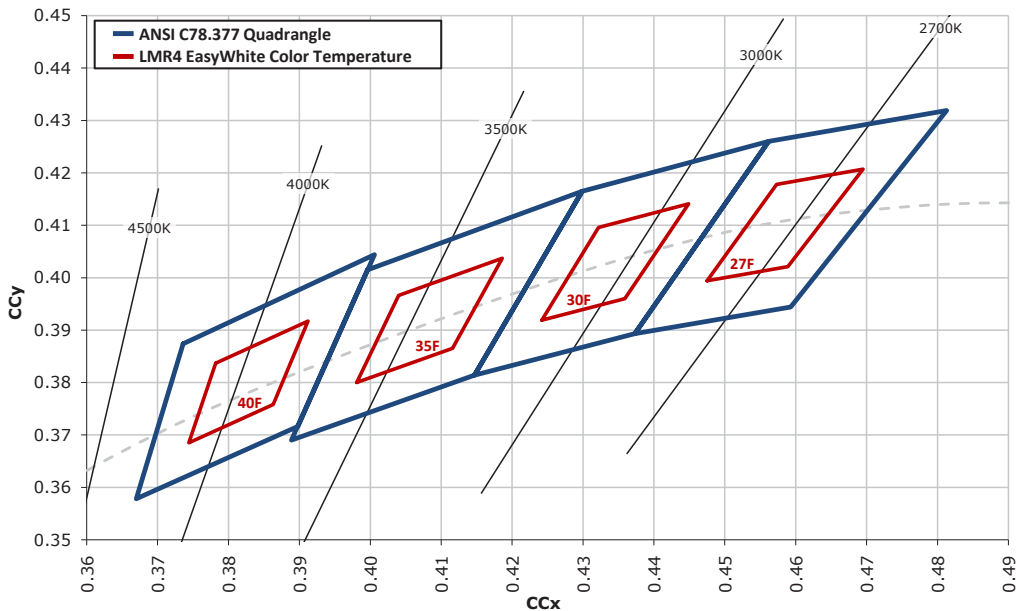



## Order Codes

---

