

CUSTOMER :

DATE : 2012.08.06

Application Note

PRODUCT NAME : 9W AC Direct Module(230V)

MODEL NAME : LLBMLW4-09D701A

CUSTOMER P/N :

APPROVAL	REMARK

APPENDIX

Designed	Checked	Approved	LG Innotek Co., Ltd.	
			DOCUMENT No.	
KT JOO	TY CHOI	SH LEE	PAGE	1 / 12

REG. DATE : 2012. 07. 30

Application Note

REV.NO : 0.3

REV. DATE : 2012. 08. 30

MODEL NAME LLBMLW4-09D701A

PAGE : 3 / 15

CONTENTS

1. Driver IC Configurations

1-1 Description	-----	4/15
1-2 Outline	-----	5/15
1-3 Pin Description	-----	5/15
1-4 Absolute Maximum Ratings	-----	5/15

2. LG Innotek IC Module Circuit configurations

2-1 Outline of module	-----	6/15
2-2 Optical characteristics	-----	6/15
2-3 Electrical characteristics	-----	7/15
2-4 Circuit configuration – 9W Module	-----	7/15
2-5 Functional Description of LG Innotek AC module_230V 9W Module	-----	8/15
2-6 Surge Protection Circuit	-----	9/15
2-7 Withstanding voltage	-----	9/15
2-8 Fixture Guide for Withstanding voltage	-----	10/15
2-9. EMI Reduction Circuit	-----	11,12/15
2-10 Dimming Performance(TRIAC Dimmer)		
2-11 Thermal compensating circuit		

1. Driver IC Configurations

1.1 Description

The Driver IC is a high-performance which uses AC direct input to allow efficient operation of LEDs. AC-Direct scheme of this device eliminates external electrolytic capacitors and coils in LED lighting applications, providing longer lifetime, smaller form factor as well as lower bill-of-material.

Due to the patent-pending Current Wave-form-Tailored (CWT) technique, the device can automatically adjust current waveform to achieve low harmonics, high Power Factor, and high power efficiency with self-compensated OVP/OCP and temperature variation.

The Driver IC operates from 200VAC to 270VAC with frequency of 50/60 Hz and supplied in 20pin 5mm x 5mm QFN package

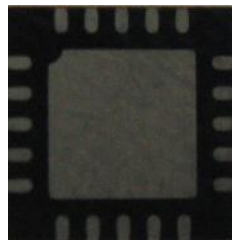

Figure 1. Driver IC PKG(20pin QFN)

▪ Features

- The smallest size: 5x5mm², 20pin QFN
- AC direct (No AC-DC conversion required)
- Coil-free and transformer-free application
- Wide input voltage: 190~280VAC
- High PF and High power efficiency
- The lowest BOM
- Very low EMI
- ESD Robustness(HBM > 2kV)

▪ Specification

- High efficiency (90%)
- High power factor (93% PF and 20% THD typical)
- Universal input VAC operation (190VAC ~ 280VAC) *Not free voltage
- 50/60 Hz operation
- Automatic over current/voltage protection
- 20LD 5mm x 5mm QFN

1. Driver IC Configurations

1.2 Outline

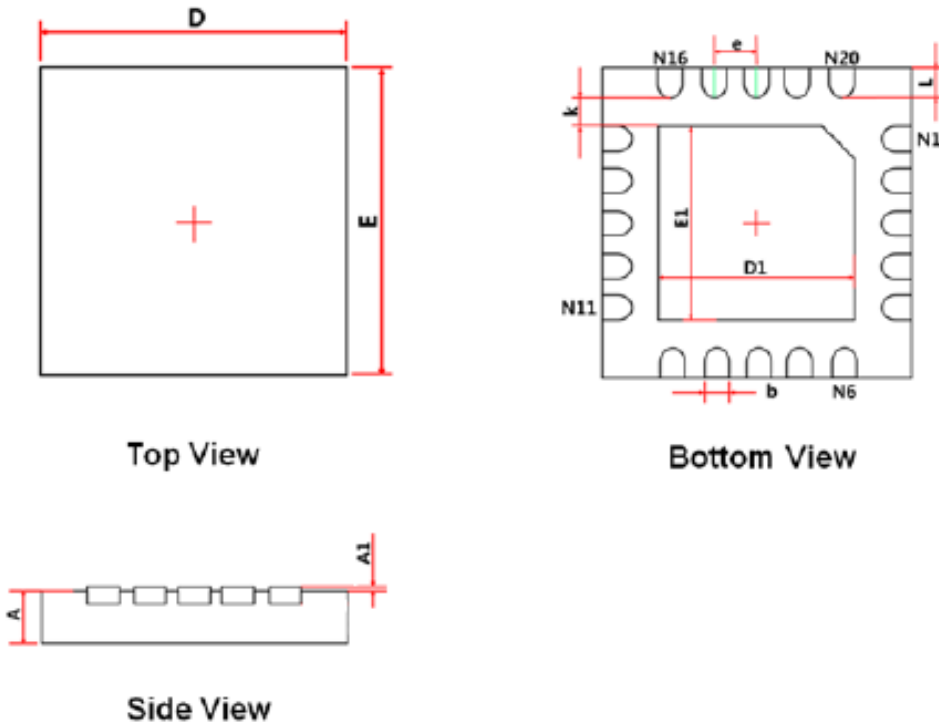

Symbol	Min.	Typ.	Max.
A	0.70	0.75	0.80
A1	0.00	0.02	0.05
D	-	5.00	-
E	-	5.00	-
D1	3.0	3.15	3.25
E1	3.0	3.15	3.25
k	0.20	-	-
b	0.25	0.30	0.35
e	-	0.65	-
L	0.45	0.55	0.65

Figure 2. Package Dimensions

REG. DATE : 2012. 07. 30

Application Note

REV.NO : 0.3

REV. DATE : 2012. 08. 30

MODEL NAME LLBMLW4-09D701A

PAGE : 6 / 15

1. Driver IC Configurations

1.3 Pin Description

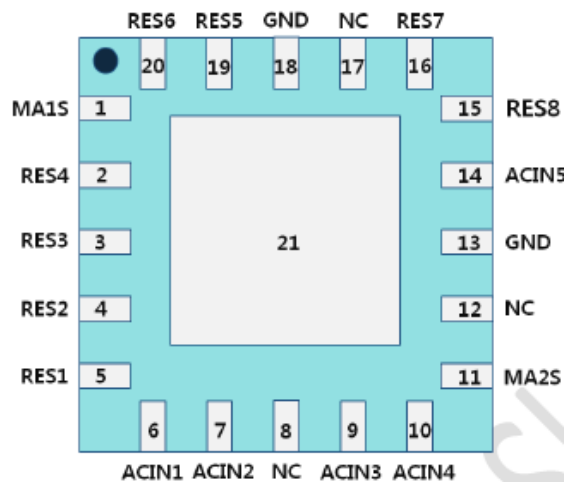

Pin No	Name	I/O	Description
1	MA1S	I/O	Current Sense Resistor1
2	RES4	I/O	Tuning Resistor 4
3	RES3	I/O	Tuning Resistor 3
4	RES2	I/O	Tuning Resistor 2
5	RES1	I/O	Tuning Resistor 1
6	ACIN1	I	AC input
7	ACIN2	I	AC input
8	NC	-	NC
9	ACIN3	I	AC input
10	ACIN4	I	AC input
11	MA2S	I/O	Current Sense Resistor 2
12	NC	-	NC
13	GND	G	Ground
14	ACIN5	I	AC input
15	RES8	I/O	Tuning Resistor 8
16	RES7	I/O	Tuning Resistor 7
17	NC	-	NC
18	GND	G	Ground
19	RES5	I/O	Tuning Resistor 5
20	RES6	I/O	Tuning Resistor 6
21	PAD	G	Ground

Figure 3. Pin Description

REG. DATE : 2012. 07. 30

Application Note

REV.NO : 0.3

REV. DATE : 2012. 08. 30

MODEL NAME LLBMLW4-09D701A

PAGE : 7 / 15

1. Driver IC Configurations

1.4 Absolute Maximum Ratings

Parameter	Symbol	Min.	Typ.	Max	Unit
Maximum Operating voltage	V _{max}	190		280	V _{rms}
Operating Temperature	T _{op}	-40		+85	°C
Storage Temperature	T _{st}	-55		+125	°C
ESD Susceptibility-HBM	V _{HBM}	2k			V
ESD Susceptibility-MM	V _{MM}	200			V
Maximum Junction Temperature	T _j			+125	°C
Lead Temperature(soldering, 10sec)	T _l			260	°C

Table 1. Absolute Maximum Ratings

Note:

1. The above table represents stress ratings only. Stresses beyond those listed in this table may cause permanent damage to the device. Functional operation of the device at these or any other conditions beyond those indicated in the specifications is not implied. Exposure to absolute maximum rating conditions for extended periods may affect device reliability.
2. HBM (Human Body Model) standard is "MIL-STD-883 Method 3015.7".
3. MM (Machine Model) standard is "EIAJ ED-4701 Method C-111"

REG. DATE : 2012. 07. 30

Application Note

REV.NO : 0.3

REV. DATE : 2012. 08. 30

MODEL NAME LLBMLW4-09D701A

PAGE : 8 / 15

2. LG Innotek Module Circuit configurations

2.1 Outline of Module

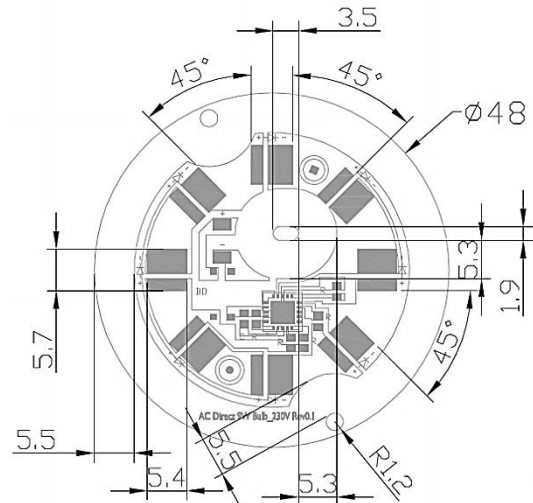
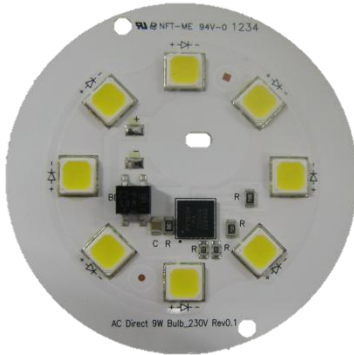

Figure 4. 230V_9W Module Dimensions

2.2 Optical characteristics

	Item	Spec.			Remarks
		Min	Typ	Max	
2700K	Flux(lm)	616	700	84	Vin=230V, 50Hz Ta=25°C
	Efficiency(lm/W)	68	78	87.1	
	CCT(K)	2,580K	2,700K	2,870K	
	CRI(ra)	80			
	View Angle	-	120°	-	
5700K	Flux(lm)	630	770	860	
	Efficiency(lm/W)	75	85	95	
	CCT(K)	5,310	5,700K	6,020K	
	CRI(ra)	75			
	View Angle	-	120°	-	

Table 2. Optical characteristics(5700K)

 Note: Measurement Tolerance : Flux \pm 5%, CIE x,y \pm 5%

2.3 Electrical characteristics

Item	Min.	Spec.		Remark
		Typ.	Max.	
Operating Voltage	220V/230V/240V			@230V, 50Hz
Power Consumption	8.1W	9W	9.9W	
Efficiency	83%	86%	-	
Power Factor ◇CTQ◇	0.9			
THD ◇CTQ◇			30%	

Table 3. Electrical characteristics

2. LG Innotek Module Circuit configurations

2.4 Circuit configuration – 9W Module

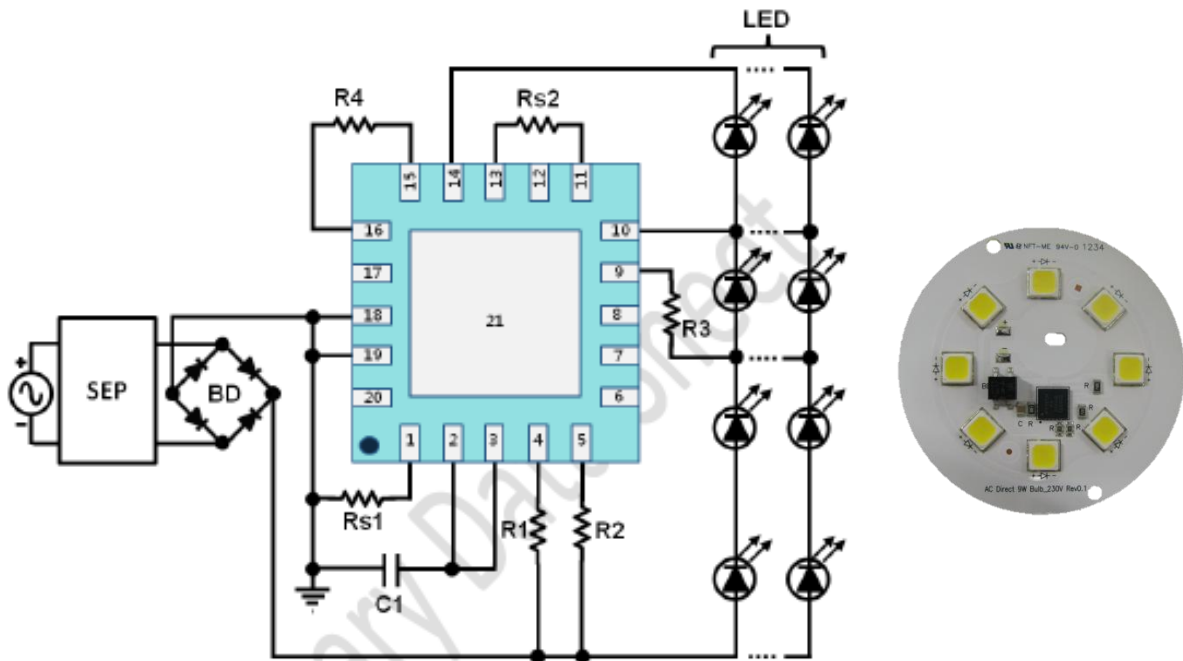

Part Name	Size/Spec.	Description
Driver IC	5X5mm ² , 20LD	LED Driver IC
LED	V _f =67V	HV LED
SEP	Surge/EMI Protection Circuit	
BD	600V	Bridge diode
R1	1005, ±1%	Resistor
R2	1005, ±1%	Resistor
R3	3216	Resistor
R4	3216	Resistor
C1	1608	Capacitor
Rs1	3216	Resistor
Rs2	3216	Resistor

Figure 5. 230V Circuit configurations

2. LG Innotek Module Circuit configurations

2.5 Functional Description of LG Innotek AC module_230V 9W Module

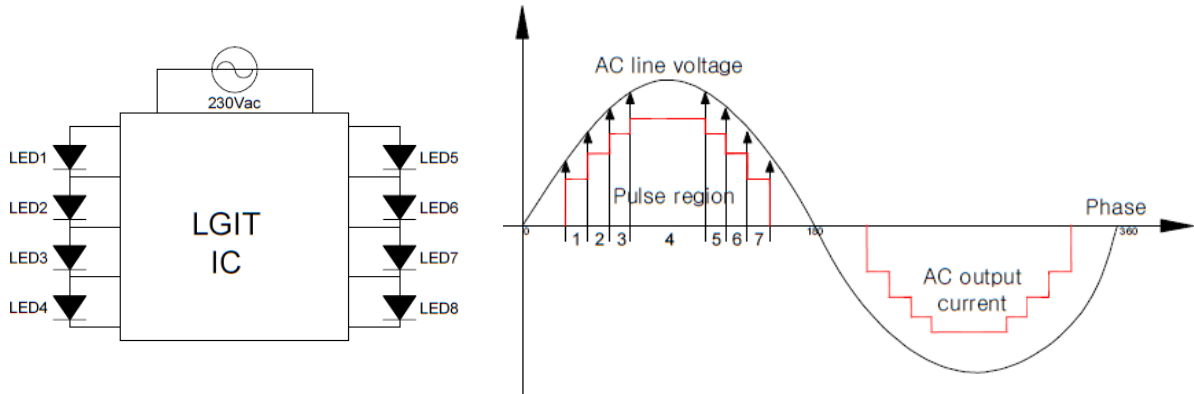

Figure 6. 230V Circuit configurations(left) / AC output current(right)

Pulse region	1	2	3	4	5	6	7
LED 1, 5	○	○	○	○	○	○	○
LED 2, 6		○	○	○	○	○	
LED 3, 7			○	○	○		
LED 4, 8				○			

Table 4. Operation of 8 LED Channels(phase 0~180°)

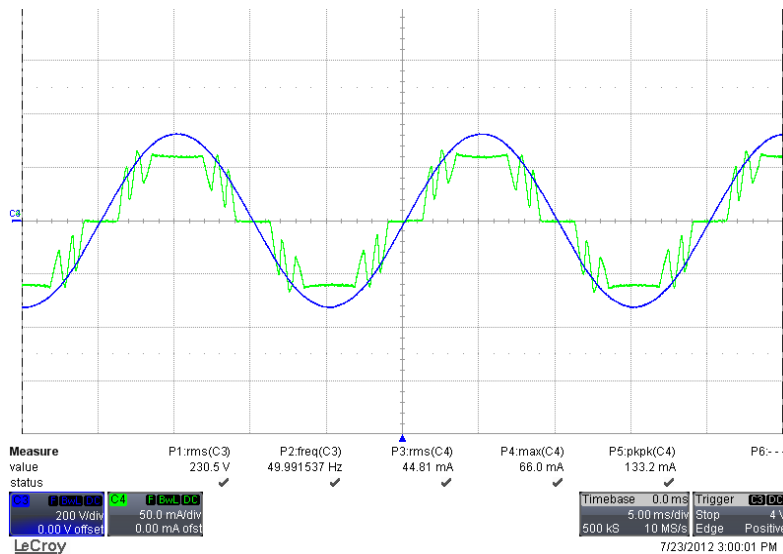

Figure 7. AC output current waveform

2. LG Innotek Module Circuit configurations

2.6 Surge Protection Circuit

A metal oxide varistor (MOV) is often used to protect lighting systems from electrical surges and ring-wave effects, and help manufacturers meet safety and performance standards. The MOV prevents short-duration voltage impulse.

Lightning tests (IEC 61000-4-5) and ring-wave Tests (IEEE C.62.41) can be used for these real-life threat simulation in the lab.

A surge protection circuit (SPC) consists of two components (MOV & fusible resistor) and it is not necessary for normal operation of the module.

Driver IC

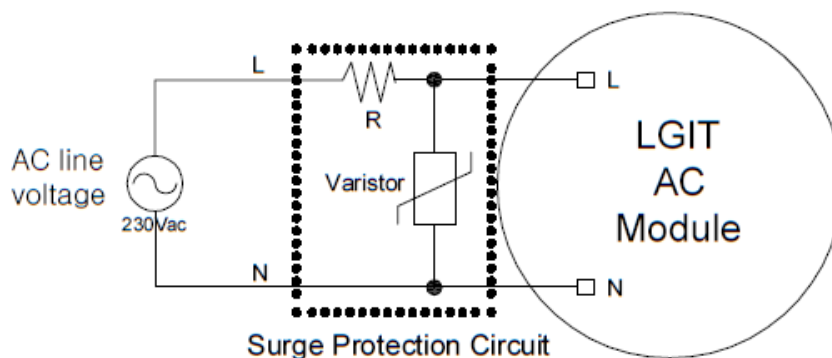

Figure 8. Surge Protection Circuit

Item	Conditions	Surge Waveform
Coupling	L-N	
Surge Voltage	$\pm 0.5\text{kV}$	
Surge Waveform	Open circuit voltage 1.2/50usec	
Total Number of Pulse	40times	
Pulse Interval Time	30sec	
Phase Angle	$0^\circ, 90^\circ, 180^\circ, 270^\circ$	

Table 5. Surge Standard(IEC 61000-4-5) & Conditions

2. LG Innotek Module Circuit configurations

2.7 Withstanding voltage

Metal PCB is used to protect lighting systems from electrical withstanding voltage. The PCB's insulation adhesive is 50µm enduring 7.5kV in Dielectric breakdown voltage. Lightning tests (IEC 60204) can be used for these real-life threat simulation in the lab.

Standard	Orthovoltage	Withstanding voltage	Leakage current	Total test time
IEC 60204	220V	2.88kV	10mA	1min
	100V	1.24kV	10mA	1min

Table 6. Withstanding voltage(IEC 60204) & Conditions

2.8 Fixture Guide for Withstanding voltage

The Insulation distance on AC direct module is retained 4.8mm from any conductor face according to UL1993.

LG Innotek module basically is designed minimum 5mm away from hole and enclosure. You can use any metal heatsink, any insulation pad .

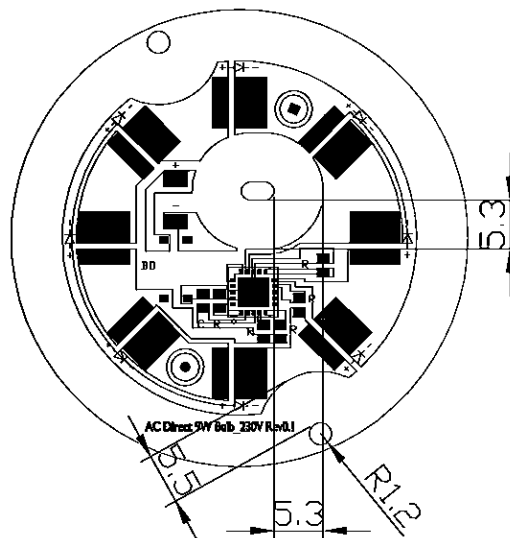

Figure 9. Insulation distance for Withstanding voltage

2. LG Innotek Module Circuit configurations

2.9 EMI Reduction Circuit

Driver IC Is basically designed to reduce EMI of conducted emission and radiated emission with inside

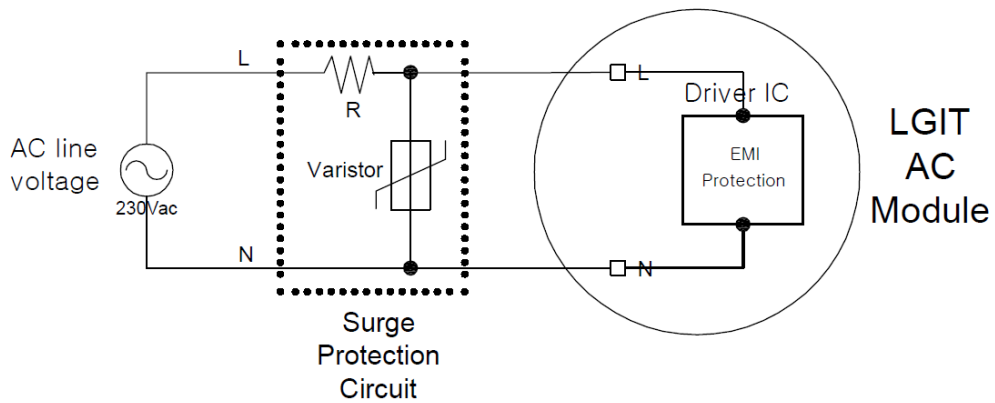

Figure 10. EMI Reduction Circuit

Standard	EMI	Frequency
EN55015 / CISPR15	Conducted Emission	9kHz ~ 30MHz
	Radiated Emission	30MHz ~ 300MHz

Table 7. EMI Standard

2. LG Innotek Module Circuit configurations

2.10 Dimming Performance(TRIAC Dimmer)

Basically, LG Innotek Module does not support dimming function.

But if you want to use it with dimmers, dimming performance is below.

Module's dimming performance shows different range according to dimmer types

Voltage	Manufacture	Product	SPEC	Region
230V~ 240V	Gira	GIRA 2262	230V/240V, 50Hz, 20~500W/VA	EUROPE
	Busch-Jaeger	Busch 2247 U	230V, 50Hz, 500W/VA	EUROPE (Germany)
	Jung	JUNG 225 NVDE	230V/240V, 60~600W, 50Hz	EUROPE (Germany)
	Jung	JUNG 225 GDE	230V, 60~600W, 50Hz	EUROPE (Germany)
	CLIPSAL	CLIPSAL 32E450UDM	230V/240V, 50Hz, 20~500W/VA	EUROPE

Table 8. Test Dimmer list

Dimmer	Parameter	0%	25%	50%	75%	100%	Range
GIRA 2262	lin[A _{rms}]	0.010	0.010	0.008	0.026	0.041	70%
	Dim[%]	20%	21%	28%	57%	90%	
Busch 2247U	lin[A _{rms}]	0.013	0.010	0.013	0.028	0.042	65%
	Dim[%]	27%	21%	29%	61%	92%	
JUNG 225 NVDE	lin[A _{rms}]	0.010	0.007	0.018	0.033	0.041	70%
	Dim[%]	22%	14%	40%	73%	92%	
JUNG 266 GDE	lin[A _{rms}]	0.000	0.000	0.007	0.015	0.032	55%
	Dim[%]	0%	0%	15%	33%	70%	
CLIPSAL 32E450UDM	lin[A _{rms}]	0.008	0.008	0.018	0.033	0.039	68%
	Dim[%]	18%	19%	40%	73%	86%	

Table 9. Experimental Test Results of LG Innotek IC Module_Dimming Range¹⁾

1)Dimming Range

- Min. Dimming Range (Travel Min) : Min. Light Output (With Dimmer) / Light Output (W/O Dimmer)
- Max. Dimming Range (Travel Max) : Max. Light Output (With Dimmer) / Light Output (W/O Dimmer)

2. LG Innotek Module Circuit configurations

2.10 Dimming Performance(TRIAC Dimmer)

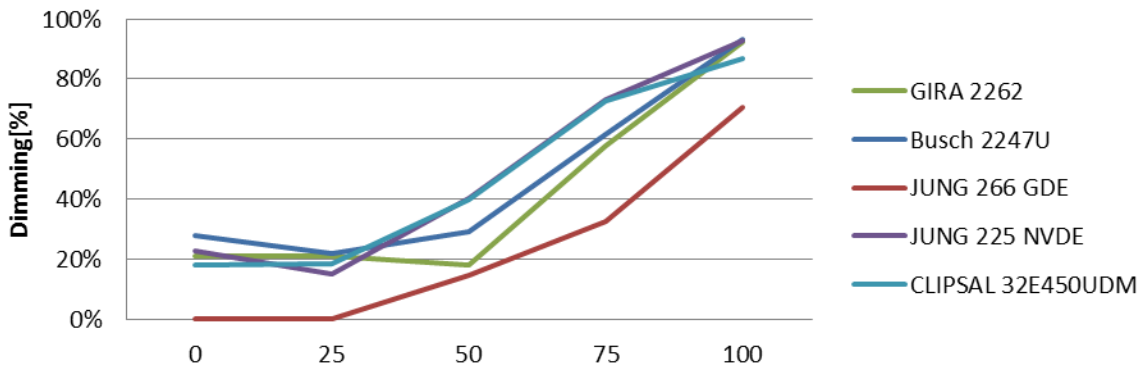

Figure 11. Dimming Profile on the Phase Angle

2.11 Thermal compensating circuit

LG Innotek module is designed thermal compensating circuit for safe operation of driver IC. Output wattage varies according to the temperature sensing driver IC inside. It is necessary to make a better heat dissipation referring below data.

Time (min)	Output Wattage(W)	Output Current(mA)	THD (%)	Power Factor(%)	LED 1_Ts (°C)	LED 2_Ts (°C)	Driver_Tj (°C)
0	10.54	47.68	26.81	0.9627	28	28	28
5	10.04	44.96	24.9	0.97	50	48	56
10	9.78	43.8	24	0.972	56.7	54.7	63.4
20	9.54	42.63	23.54	0.973	60.8	58.9	67.8
30	9.47	42	23.37	0.974	62	60.2	69.2
60	9.47	42	23.36	0.973	62	59.8	68.4

Table 9. Wattage according to the Driver IC Temperature

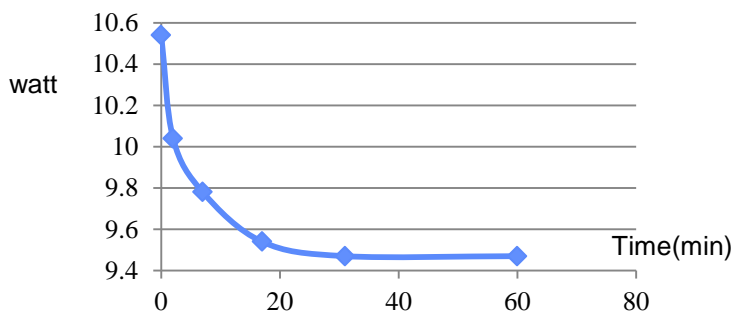

Figure 12. Wattage rate of change after aging