

AN8377N

3-channel Linear Driver

Overview

The AN8377N is an IC which incorporates 3 circuits of BTL drivers for driving various DC motors such as actuators (focus, tracking, traverse), spindles, and loading of the CD players, and the +5V low drop type power supply.

Features

- Operating supply voltage range ; $V_{CC}=5.5V$ to $18V$
- Built-in 3 circuits of voltage BTL drivers
(maximum drive current : $500mA$)
- Stable circuit operation against supply voltage change and temperature change due to the built-in stabilized power supply
- Built-in +5V low drop power supply (external PNP power transistor)
- Built-in reset circuit (reset voltage : $4.82V$)
- Built-in thermal protective circuit (operating temperature : 159 ; typ.)
- Built-in power cut circuit (motor driver 1 only)

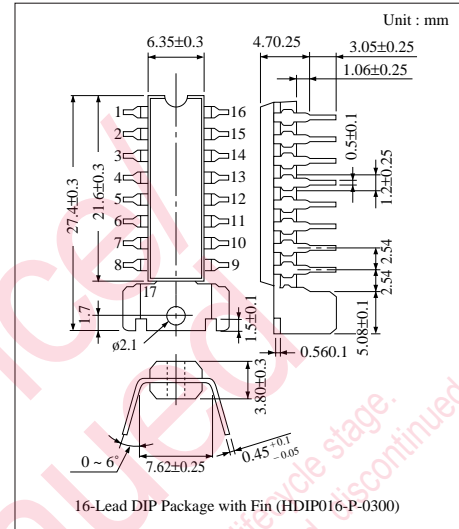

Applications

Linear driving of the DC motors and actuators of the CD players, CD radio cassette tape recorder, and so on.

Block Diagram

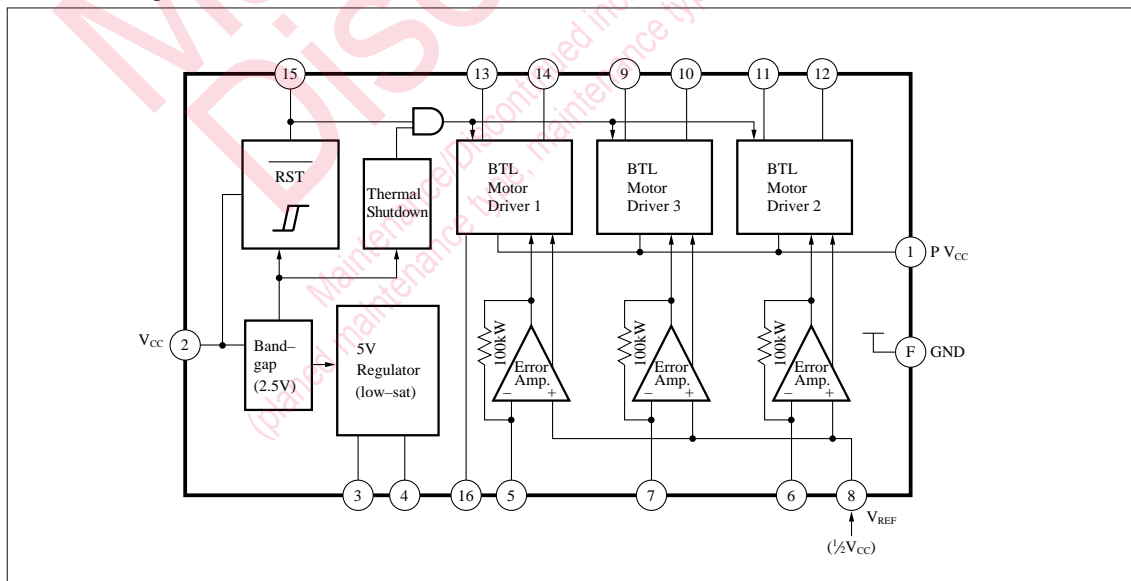

■ Absolute Maximum Ratings (Ta=25°C)

Parameter	Symbol	Rating	Unit
Supply Voltage	V _{CC}	20	V
Power Dissipation	P _D	1500	mW
Operating Ambient Temperature	T _{opr}	-25 ~ +80	°C
Storage Temperature	T _{stg}	-55 ~ +150	°C

■ Recommended Operating Range (Ta=25°C)

Parameter	Symbol	Range
Operating Supply Voltage Range	V _{CC}	5.5V ~ 16V

■ Electrical Characteristics (Ta=25°C)

Parameter	Symbol	Condition	min.	typ.	max.	Unit
No Load Current	I _{CC}	V _{CC} =12V	7	10.5	15	mA
5V Regulator Output Voltage	V _{RO}	V _{CC} =12V, R _L =50W	4.75	5	5.25	V
5V Regulator Load Change	DV _{RI}	V _{CC} =12V, R _L =50W ~ 25W	-15	—	30	mV
5V Regulator Input Change	DV _{RVC}	V _{CC} =15.5V ~ 5.5V, R _L =50W	-15	—	50	mV
Reset Threshold Voltage	V _{RST}		4.55	4.82	5.1	V
Reset Threshold Hysteresis Width	V _{HYS}		90	170	310	mV
Reset Operating Minimum Voltage	V _{R (min.)}	Minimum V _{CC} Voltage at which V15=Low	3.1	—	—	V
Input Offset Voltage	V _{IOF}	V _{CC} =18V, R _L =20W, R _{IN} =10kW	-7	—	7	mV
Output Offset Voltage	V _{OOF}	V _{CC} =18V, R _L =20W, R _{IN} =10kW	-50	—	50	mV
Gain (+)	G ₊	V _{CC} =18V, R _L =20W, R _{IN} =10kW	16.5	20	22.5	dB
(+) (-) Relative Gain	G _R	V _{CC} =18V, R _L =20W, R _{IN} =10kW	-0.85	—	0.85	dB
Limit Voltage (+)	V _{L+}	V _{CC} =18V, R _L =20W, R _{IN} =10kW	7.1	—	10.9	V
Limit Voltage (-)	V _{L-}	V _{CC} =18V, R _L =20W, R _{IN} =10kW	-10.9	—	-7.1	V
Dead Zone Width	V _{DZ}	V _{CC} =18V, R _L =20W, R _{IN} =10kW	-10	—	30	mV
PC Input Threshold (L)	V _{FCL}	V _{CC} =18V	—	—	1.2	V
PC Input Threshold (H)	V _{PCH}	V _{CC} =18V	2.8	—	—	V
Motor Driver 2 Output Voltage at Reset	V _{2RS}	V _{CC} =3.5V, R _L =10kW	-50	—	50	mV
Motor Driver 3 Output Voltage at Reset	V _{3RS}	V _{CC} =3.5V, R _L =10kW	-50	—	50	mV
Motor Driver 1 Output Voltage at Reset	V _{1RS}	V _{CC} =3.5V, R _L =10kW	-50	—	50	mV
5V Regulator External Transistor Base Current Limit Value	I _{3LIM}		9	12	16	mA
Thermal Protective Circuit Operating Temperature Balancing Value	T _{THD}		—	159	—	°C
Thermal Protective Circuit Operating Temperature Hysteresis Width	DT _{THD}		—	64	—	°C

Note) The specified values of V_{IOF}, V_{OOF}, G₊, G_R, V_{L+}, V_{L-}, and V_{DZ} are common ones for each of the motor driver 1, motor driver 2, and motor driver 3 circuits.

■ Application Circuit

(Used when driving the focus, tracking actuator, and traverse motor)

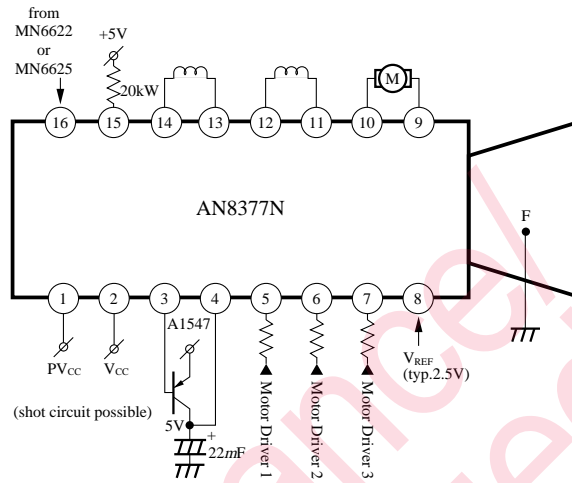

■ Pin Descriptions (The following description applies when the 3 channels for the motor drivers 1, 2, and 3 are used.)

Pin No.	Symbol	I/O	DC Voltage (V _{CC} /12V)	Equivalent Circuit	Description
1	PV _{CC}	I	12V		Power V _{CC} pin. Supplies a current flowing to the output power transistor.
2	V _{CC}	I	12V		V _{CC} pin. Not connected to the power V _{CC} pin.
3	TB	O	11.3V		External PNP transistor base connection pin
4	V _{MON}	I	5V		External PNP transistor collector connection pin (=5V output pin)

■ Pin Descriptions (Cont.) (The following description applies when the 3 channels for the motor drivers 1, 2, and 3 are used.)

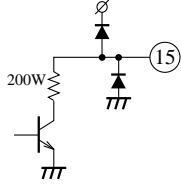
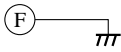
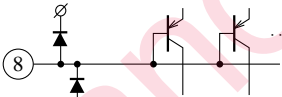
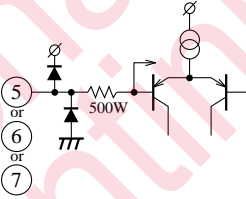
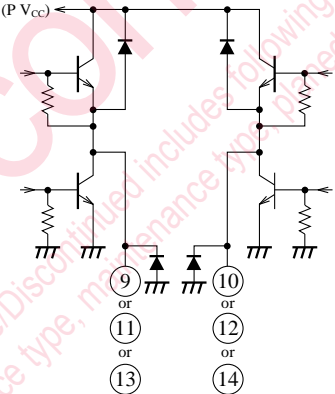
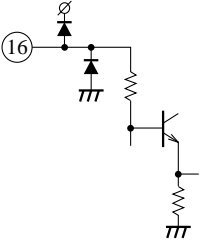
Pin No.	Symbol	I/O	DC Voltage (V _{CC} /12V)	Equivalent Circuit	Description	
15	$\overline{\text{RST}}$	O	—		Reset output pin. Open collector output type.	
F	GND	I	0V		GND pin	
8	V _{REF}	I	2.5V		V _{REF} input pin	
5	TVDI	I	2.5V		Driver 1 error input pin	
6	FDI	I	2.5V		Driver 2 error input pin	
7	TDI	I	2.5V		Driver 3 error input pin	
9	TD ⁻	O	(0.3V)		BTL driver 3 inverting output pin	
10	TD ⁺	O	(0.3V)		BTL driver 3 non-inverting output pin	
11	FD ⁻	O	(0.3V)		BTL driver 2 inverting output pin	
12	FD ⁺	O	(0.3V)		BTL driver 2 non-inverting output pin	
13	TVD ⁻	O	(0V)		BTL driver 1 inverting output pin	
14	TVD ⁺	O	(0V)		BTL driver 1 non-inverting output pin	
16	PC	I	0V			PC (power cut) input pin

Request for your special attention and precautions in using the technical information and semiconductors described in this book

- (1) If any of the products or technical information described in this book is to be exported or provided to non-residents, the laws and regulations of the exporting country, especially, those with regard to security export control, must be observed.
- (2) The technical information described in this book is intended only to show the main characteristics and application circuit examples of the products, and no license is granted under any intellectual property right or other right owned by our company or any other company. Therefore, no responsibility is assumed by our company as to the infringement upon any such right owned by any other company which may arise as a result of the use of technical information described in this book.
- (3) The products described in this book are intended to be used for standard applications or general electronic equipment (such as office equipment, communications equipment, measuring instruments and household appliances).
Consult our sales staff in advance for information on the following applications:
 - Special applications (such as for airplanes, aerospace, automobiles, traffic control equipment, combustion equipment, life support systems and safety devices) in which exceptional quality and reliability are required, or if the failure or malfunction of the products may directly jeopardize life or harm the human body.
 - Any applications other than the standard applications intended.
- (4) The products and product specifications described in this book are subject to change without notice for modification and/or improvement. At the final stage of your design, purchasing, or use of the products, therefore, ask for the most up-to-date Product Standards in advance to make sure that the latest specifications satisfy your requirements.
- (5) When designing your equipment, comply with the range of absolute maximum rating and the guaranteed operating conditions (operating power supply voltage and operating environment etc.). Especially, please be careful not to exceed the range of absolute maximum rating on the transient state, such as power-on, power-off and mode-switching. Otherwise, we will not be liable for any defect which may arise later in your equipment.
 - Even when the products are used within the guaranteed values, take into the consideration of incidence of break down and failure mode, possible to occur to semiconductor products. Measures on the systems such as redundant design, arresting the spread of fire or preventing glitch are recommended in order to prevent physical injury, fire, social damages, for example, by using the products.
- (6) Comply with the instructions for use in order to prevent breakdown and characteristics change due to external factors (ESD, EOS, thermal stress and mechanical stress) at the time of handling, mounting or at customer's process. When using products for which damp-proof packing is required, satisfy the conditions, such as shelf life and the elapsed time since first opening the packages.
- (7) This book may be not reprinted or reproduced whether wholly or partially, without the prior written permission of Matsushita Electric Industrial Co., Ltd.