

Compact product length of travel +15mm and improved operating feel

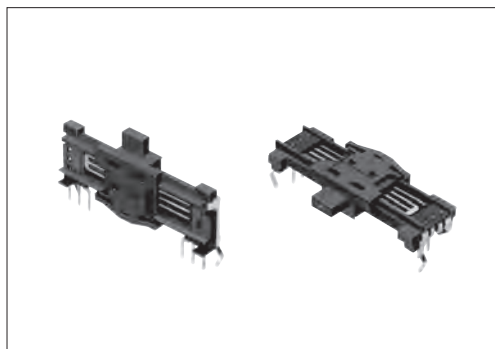

■ Typical Specifications



Items	Specifications
Total resistance tolerance	±20%
Maximum operating voltage	Please see P.362
Operating force	0.6 ^{+0.5} _{-0.4} N
Operating life	10,000 cycles
Operating temperature range	-25°C to +70°C

■ Product Line

Number of resistor elements	Direction of lever	Travel (mm)	Lever types	Length of lever L ₁ (mm)	Total resistance (k Ω)	Resistance taper	Detent	Minimum order unit (pcs.)		Products No.	Drawing No.
								Japan	Export		
Single-unit	Vertical	15	C	9.5	50	1B	Without	2,900	5,800	RS15H111CA04	1
		20		14.5				2,500	5,000	RS20H111C009	2
		30	A	4.5	10	15A		2,000	4,000	RS30H111A00D	3
	Horizontal	15				1B		2,750	5,500	RS15H11AA008	7
		20						RS20H11AA015	8		
	30	15A	1,980	3,960	RS30H11AA009	9					
Dual-unit	Vertical	15	C	9.5	100	1B	With	2,900	5,800	RS15H121A009	4
		20		2,500				5,000	RS20H123A01C	5	
		30	A	4.5	10	1B		2,000	4,000	RS30H121A00B	6
	Horizontal	15					3B	2,750	5,500	RS15H12AA00F	10
		20								RS20H12AC002	11
	30	A	4.5	50	15A	1,980	3,960	RS30H12AA003	12		

Note

Other varieties are also available. Refer to "Other Specifications" (P.362).

■ Packing Specifications

Tray

Product No. (mm)	Direction of lever	Number of packages (pcs.)		Export package measurements (mm)
		1 case /Japan	1 case /export packing	
15	Vertical	2,900	5,800	378×514×512
	Horizontal	2,750	5,500	374×508×408
20	Vertical	2,500	5,000	378×514×512
	Horizontal	2,750	5,500	374×508×408
30	Vertical	2,000	4,000	378×514×512
	Horizontal	1,980	3,960	374×508×408

Refer to P.362 for other specifications.
 Refer to P.362 for configuration details.
 Refer to P.363 for ordering products not listed.
 Refer to P.383 for soldering conditions.

Dimensions

Unit:mm

No.	Style	PC board mounting hole dimensions (Viewed from mounting side)
1		
2		
3		
4		

The length of Lever (L₁) can be customized. Refer to P.362 for details.

Rotary Potentiometers

Slide Potentiometers

General-use

Mixer

■ Dimensions

Unit:mm

No.	Style	PC board mounting hole dimensions (Viewed from mounting side)
5		
6		
7		
8		

Rotary
Potentiometers

Slide
Potentiometers

General-use
Mixer

Dimensions

Unit:mm

No.	Style	PC board mounting hole dimensions (Viewed from mounting side)			
9	<div style="display: flex; align-items: center; margin-bottom: 10px;"> <table border="1" style="margin-right: 10px;"> <tr> <td>L₁</td> <td>4.5</td> <td>9.5</td> </tr> </table> </div>	L ₁	4.5	9.5	
L ₁	4.5	9.5			
10					
11					
12					

The length of Lever (L₁) can be customized. Refer to P.362 for details.

Rotary Potentiometers

Slide Potentiometers

General-use

Mixer

Slim Slide™ (Slim 4) / Other Specifications

In addition to the products listed, we can accommodate the follow specifications.

Travel Distance Variety

Travel (mm)	15	20	30
-------------	----	----	----

Total Resistance Variety

Total resistance (k Ω)	5	10	20	50	100	200	250
------------------------	---	----	----	----	-----	-----	-----

Resistance Taper

Resistance taper	15A	1B	3B
------------------	-----	----	----

Note

DC (10V DC) is also available. (Tapped types are not available)

Rated Power

Travel	Resistance taper	
	15A	1B, 3B
15mm	0.012W	0.025W
20mm	0.025W	0.05W
30mm	0.05W	0.1W

Maximum Operating Voltage

Travel	Resistance taper	
	15A	1B, 3B
15mm	50V AC, 10V DC	100V AC, 10V DC
20mm		
30mm	150V AC, 10V DC	200V AC, 10V DC

Terminal Layout / Circuit Diagram (Viewed from Mounting Side)

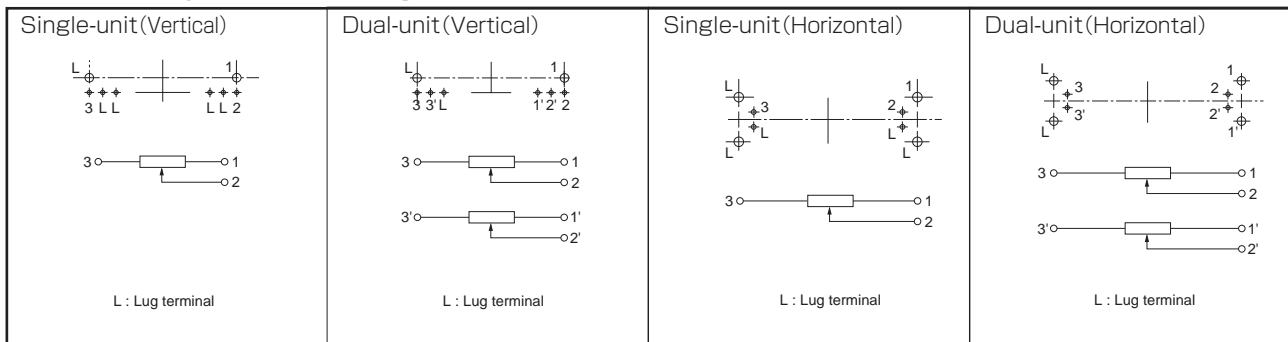

Lever Types

Configuration code	A		C		D	
Dimensions						
Length L ₁	4.5	9.5	9.5	14.5	9.5	14.5

Corresponding Specifications

Tap	Possible only at center position
-----	----------------------------------

Note

- The color of the D-type lever is black. Please specify the color of the marker: red, green, orange or white.
- Marked are specifications recommended by Alps Alpine.

When ordering product varieties that are not listed, specify referring to the examples below.

Sample Part Number

R S 3 0 H 1 1 1 - A 0 9 5 - B 1 0 3

Travel

Code	Travel (mm)
15	15
20	20
30	30

Number of resistor elements

Code	Number of resistor elements
1	Single
2	Dual

Direction of lever and center detent

Code	Direction of lever	Center detent
1	Vertical	Without
3		With
A	Horizontal	Without
C		With

Lever type

Code
A
C
D

Length of lever

Code	Length L ₁ (mm)
045	4.5
095	9.5
145	14.5

Total resistance

Code	Total resistance (kΩ)	Code	Total resistance (kΩ)
502	5	104	100
103	10	204	200
203	20	254	250
503	50	—	—

Resistance taper

Code	Resistance taper
A	15A
B	1B
V	3B

B: For tone & general V: For vol.

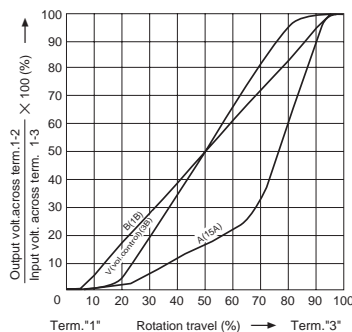







Note

Marked are specifications recommended by Alps Alpine.

Slide Potentiometers

List of Varieties

Type		Standard Type			Master Type
Series		Super Slide™	Slim Slide™ (Slim 4)	Compact Reflow Type	K Fader
		RS □□ 1	RS □□ H	RS08U	RS □□ K
		Single-unit/Dual-unit	Single-unit/Dual-unit	Single-unit	Single-unit/Dual-unit
Photo					
Travel (mm)		15, 20, 30, 45, 60	15, 20, 30	8	60, 100
Direction of lever		Vertical		Horizontal	Vertical
Lever material		Metal / Resin	Resin	Resin	Metal
Operating temperature range		-25°C to +70°C		-10°C to +70°C	-10°C to +60°C
Operating life		15,000 cycles	10,000 cycles		100,000 cycles (Standard) 300,000 cycles (CP)
Available for automotive use		○	—	—	—
Life cycle (availability)					
Electrical performance	Total resistance (k Ω)	10, 20, 50, 100, 200	5, 10, 20, 50, 100, 200, 250	10	10, 50, 100 (Standard) 10 (CP)
	Resistance taper	10A, 15A, 1B, 3B, 4B	15A, 1B, 3B	1B	15A, 1B
	Rated Power	Please see P.355	Please see P.362	0.025W	0.25W
	Insulation resistance	100MΩ min. 250V DC	Dual-unit: 100MΩ min. 250V DC	100MΩ min. 100V DC	100MΩ min. 250V DC
	Voltage proof	300V AC for 1 minute	Dual-unit: 300V AC for 1 minute	100V AC for 1 minute	250V AC for 1 minute
	Center-taps	Without / With		Without	
Mechanical performance	Operating force	0.3 to 2.5N	0.6 ^{+0.5} _{-0.4} N	0.17±0.15N	Please see P.368
	Center detent	Without / With		Without	
	Stopper strength	50N	30N	5N	100N
	Lever push-pull strength	50N	30N	5N	100N
	Lever wobble (mm) ※ Both sides	$\frac{2(2 \times L)}{20}$	1.6 max.	—	$\frac{2(2 \times L)}{25}$
	Detent slip-out force	Operating force + (0.2 to 2N)	Operating force + 0.3 ^{+0.5} _{-0.25} N	—	—
	Lever deviation (mm) ※ One side	0.5 max.	—	—	0.5 max.
Terminal style		Insertion		Reflow	Lead (Standard) Connector (CP)
Page		351	358	364	365

Slide Potentiometers Soldering Conditions	383
Potentiometer Cautions	384
Potentiometers Measurement and Test Methods	386
Potentiometers Resistance Taper	388

Notes

- "L" in the "Lever Wobble" column of the above table indicates the length of lever.
- RS □□
 □□ indicates travel.
- Indicates applicability to some products in the series.

Reference for Manual Soldering

Series	Tip temperature	Duration of Soldering time	No. of solders
RS□□1, RS□□H, RS08U, RS□□K (Standard), RS□□N, RS6011□P, RS□□N1□M, RSA0K1□V (Motor terminal)	350°C max.	3s max.	1 time

Reference for Dip Soldering

Series	Preheating		Dip soldering		Number of soldering
	Soldering surface temperature	Heating time	Soldering temperature	Soldering time	
RS□□1, RS□□H, RS□□N, RS6011□P, RS□□N1□M	100°C max.	1 min. max.	260°C	5s max.	1 time

Example of Reflow Soldering Condition

Temperature profile

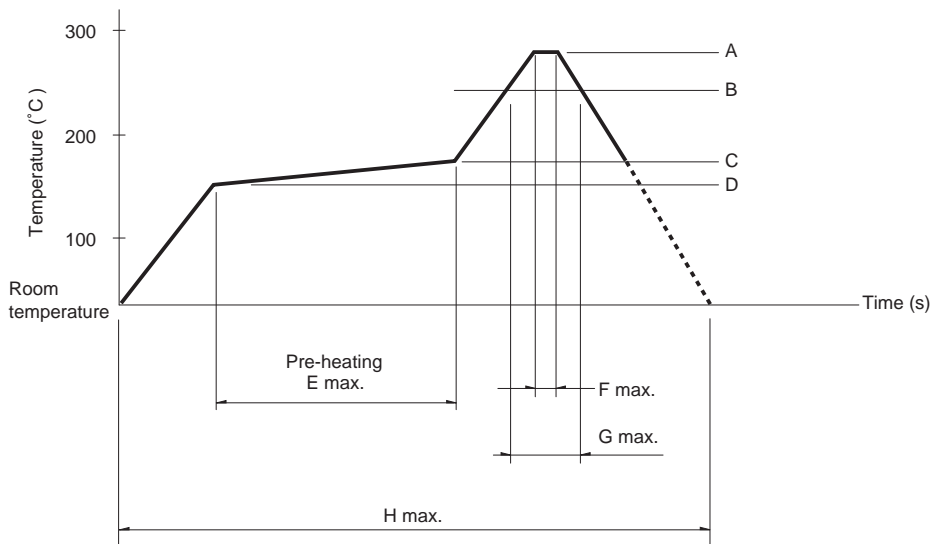

Series	A	B	C	D	E	F	G	H	No. of reflows
RS08U	250°C	200°C	150°C	150°C	2 min.	3s	40s	4 min.	1 time

Notes

1. When using an infrared reflow oven, solder may sometimes not be applied. Be sure to use a hot air reflow oven or a type that uses infrared rays in combination with hot air.
2. The temperatures given above are the maximum temperatures at the terminals of the products when employing a hot air reflow method. The temperature of the PC board and the surface temperature of the products may vary greatly depending on the PC board material, its size and thickness. Ensure that the surface temperature of the products does not rise to 250°C or greater.
3. Conditions vary to some extent depending on the type of reflow bath used. Be sure to give due consideration to this prior to use.

Mouser Electronics

Authorized Distributor

Click to View Pricing, Inventory, Delivery & Lifecycle Information:

Alps Alpine:

[RS20H111C009](#) [RS15H12AA009](#) [RS30H111A00D](#) [RS20H113C008](#) [RS20H123A01C](#) [RS15H113C001](#)
[RS30H121A00B](#) [RS20H11AA01U](#) [RS30H11AAA02](#) [RS15H113CA05](#) [RS30H12AA003](#) [RS20H12AC002](#)
[RS15H121A009](#) [RS30H11AA00G](#) [RS15H12AA00F](#) [RS20H11CA00B](#) [RS30H11AAA0B](#) [RS20H11AA015](#)
[RS15H11AA00G](#) [RS20H11AA019](#) [RS15H111CA04](#) [RS15H11AA008](#) [RS20H11AA02T](#) [RS30H11AA00P](#)
[RS15H11AA04M](#) [RS30H11AA009](#)