

# LPC – WLAN ADK Hardware User Guide Version 1.6

**Adya Systems & Software Pvt. Ltd.**

## Table of Contents

<b>1. INTRODUCTION.....</b>	<b>4</b>
<b>1.1 Purpose .....</b>	<b>4</b>
<b>1.2 Introduction .....</b>	<b>4</b>
<b>1.3 Kit Features .....</b>	<b>5</b>
<b>1.4 Picture .....</b>	<b>6</b>
<b>1.5 Schematic .....</b>	<b>7</b>
<b>1.6 Component Layout.....</b>	<b>8</b>
<b>2. HARDWARE DESCRIPTION .....</b>	<b>9</b>
<b>2.1 Peripherals .....</b>	<b>9</b>
<b>2.2 Technical Specification .....</b>	<b>9</b>
2.2.1 LPC2138 Module Specification .....	9
2.2.2 BGW200 Wireless LAN Specification .....	10
<b>2.3 Power Supply Circuit .....</b>	<b>10</b>
<b>2.4 JTAG Connector .....</b>	<b>12</b>
<b>2.5 RS232 Connector .....</b>	<b>13</b>
<b>2.6 UART Connector.....</b>	<b>14</b>
<b>2.7 Battery Connector .....</b>	<b>14</b>
<b>2.8 Jumpers.....</b>	<b>14</b>
<b>2.9 WLAN SPI Connector .....</b>	<b>15</b>
<b>2.10 SD Memory Connector .....</b>	<b>16</b>
<b>2.11 Additional Connectors.....</b>	<b>16</b>
<b>3. REPROGRAMMING THE FLASH MEMORY .....</b>	<b>17</b>
<b>3. LINKS FOR REFERENCE .....</b>	<b>19</b>

### List of Figures

Figure 1: Picture of LPC2138 WLAN Application Development Kit.....	6
Figure 2: Picture of WLAN Card.....	6
Figure 3: Schematic of LPC2138 WLAN ADK .....	7
Figure 3: LPC2138 WLAN ADK Component Layout.....	8
Figure 4: Power Supply Circuit .....	10
Figure 5: JTAG Connector .....	12
Figure 6: RS232 Connector.....	13
Figure 7: UART Connector .....	14
Figure 8: Battery Connector .....	14
Figure 9: WLAN SPI Connector.....	15
Figure 10: SD Memory Connector.....	16

## 1. INTRODUCTION

### 1.1 Purpose

The purpose of this document is to describe Adya's LPC2138 WLAN Application Development Kit. This document provides the hardware description and usage details of the WLAN ADK.

### 1.2 Introduction

The WLAN Application Development Kit provides a powerful solution for data communication in embedded devices. It operates according to the IEEE 802.11b standard, using the open 2.4 GHz ISM band. The development kit is designed for developers who wish to evaluate the module and integrate them into their application. The WLAN Application Development Kit can be a starting point for embedded wireless development.

The WLAN Application Development Kit is based on LPC2138 ARM7™ microcontroller from Philips and BGW200 Wireless chipset from Philips. The kit includes various subsystems for multiple application realization of WLAN technology like SD Memory interface on board, UART and RS232 interfaces, ADC and DAC interfaces and General Purpose Input Output (GPIO) interface.

The LPC2138 are based on a 32-bit ARM7TDMI-STM CPU with real-time emulation and embedded trace support, together with 512 kilobytes (KB) of embedded high-speed flash memory. A 128-bit wide internal memory interface and unique accelerator architecture enable 32-bit code execution at maximum clock rate. For critical code size applications, the alternative 16-bit Thumb Mode reduces code by more than 30% with minimal performance penalty.

The BGW200 from Philips is a complete low power 802.11b Wireless LAN System-in-a-Package solution optimized for low power devices. The solution enables consumers to connect to the growing number of wireless networks in offices, home and public places.

### 1.3 Kit Features

The WLAN Application Development Kit has the following features:

- ARM7 based LPC2138 microprocessor core module from Philips
- Philips BGW200 Wireless LAN (IEEE 802.11b) interface
- Standard JTAG connector with ARM 2x10 pin layout for programming/debugging with ARM-JTAG
- On board voltage regulator of 3.3V
- Single power supply: 6V DC required
- Power supply LED and status LEDs
- Power supply filtering capacitor
- One channel RS232 interface, One channel UART interface
- RESET circuit with external control of Philips ISP utility via RS232
- DBG jumper for JTAG enable
- B2S jumper for boot loader enable
- JRST jumper for enable/disable external RESET control by RS232
- 14.7456 MHz crystal (4x PLL = 58,9824 MHz CPU clock)
- 32.768 KHz crystal and RTC backup battery connector
- PCB: FR – 4, 1.5 mm (0,062"), green solder mask, white silkscreen component print
- Dimensions: 150x75 mm

## 1.4 Picture



Figure 1: Picture of LPC2138 WLAN Application Development Kit

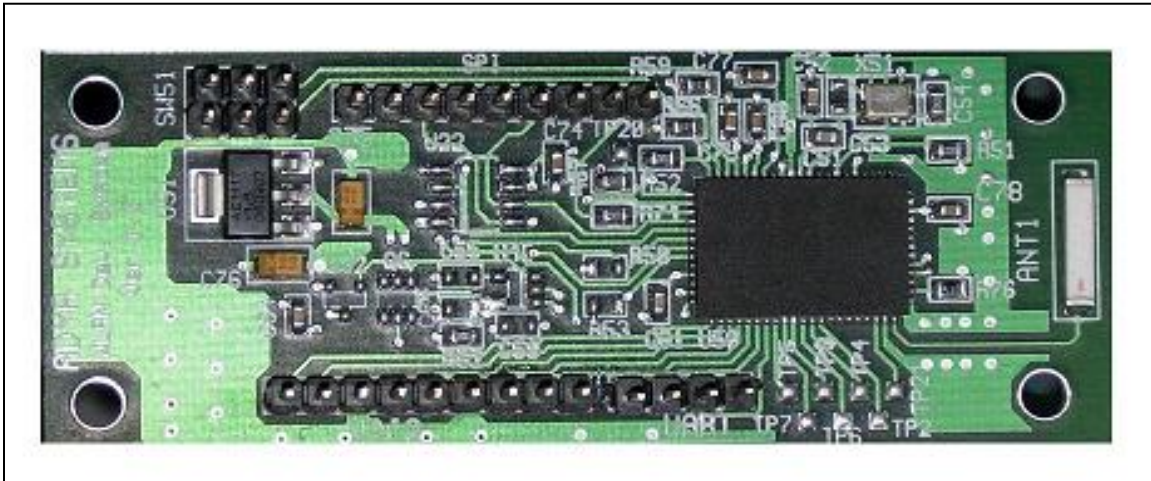

Figure 2: Picture of WLAN Card



## 1.6 Component Layout

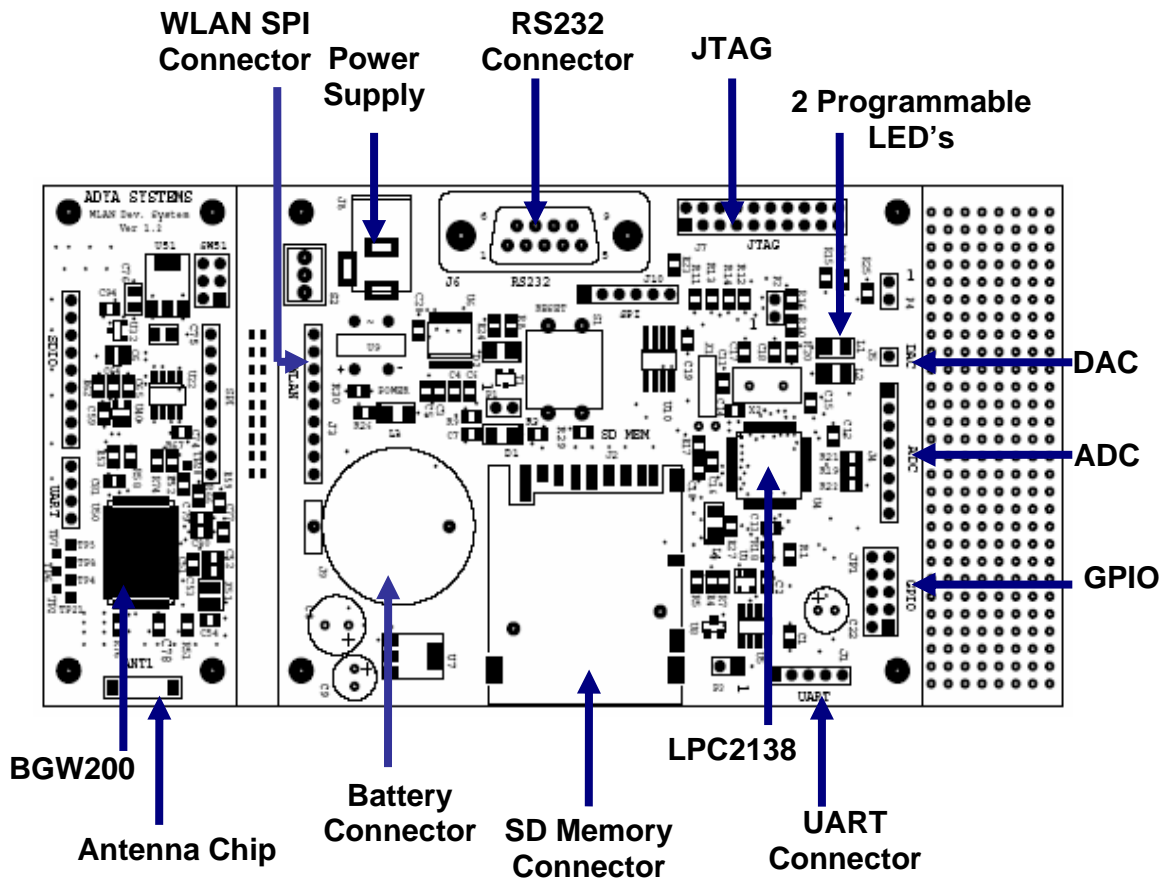

Figure 3: LPC2138 WLAN ADK Component Layout



## 2. HARDWARE DESCRIPTION

### 2.1 Peripherals

Unit	Description
COM Port	RS232 DB9 Female Connector for LPC2138 UART0.
UART	5-Pin UART interface for LPC2138 UART1
JTAG Connector	2x10 0.1" step connector for programming with ARM – JTAG.
Buttons	One push button, connected to RESET
LED	Red LED for Power Supply indication, Red status LED connected to <b>P0.31 (pin 17)</b> Red status LED connected to <b>P0.12 (pin 38)</b> Green indicator LED connected to <b>P0.13 (pin 39)</b>
ADC	8 Channel ADC interface
DAC	1 Channel DAC interface
GPIO	Configurable General Purpose Input Output
SD MEM	SD Memory Adapter connected to SSP of LPC2138
WLAN	WLAN connected to SPI0 of LPC2138

### 2.2 Technical Specification

#### 2.2.1 LPC2138 Module Specification

Parameter	Description
Voltage Supply	Min 6.0V DC, max 12.0v DC Min 4.5V AC, max 9.0V AC
Host CPU	LPC2138F
Crystals	X1 – 32.768 KHz Clock Crystal X2 – 14.7456 MHz HF Crystal
Flash	512KB
RAM	32KB
Operating Temperature	From 0°C to 55°C

### 2.2.2 BGW200 Wireless LAN Specification

Parameter	Description
Chipset	Philips BGW200 (IEEE 802.11b Wireless LAN)
Supply Voltage	3.3V
Host Interface	SPI (Serial Peripheral Interface)
Operating Frequency	2.4000 to 2.4835 GHz
Data Rate	1, 2, 5.5, 11 Mbps
Security	802.11 WEP

### 2.3 Power Supply Circuit

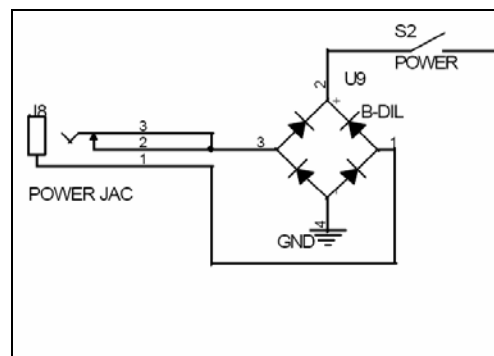

**Figure 4: Power Supply Circuit**

The power supply input connector J8 must be connected to a DC or AC voltage source. The voltage range for DC supply is minimum 6.0V DC to maximum 12.0V DC. The voltage range for AC supply is minimum 4.5V AC to maximum 9.0V AC. The input circuit is a full bridge rectifier so the polarity of the input voltage does not really matter, but at the same time recommend to use minimum 6.0V DC to maximum 12.0V DC only.

## **WARNING!**

**POWER SUPPLY RANGE MUST ADHERE TO FOLLOWING  
VALUES.**

**DC SUPPLY: +6.0 Volt**

**CURRENT: 1 Ampere**

## 2.4 JTAG Connector

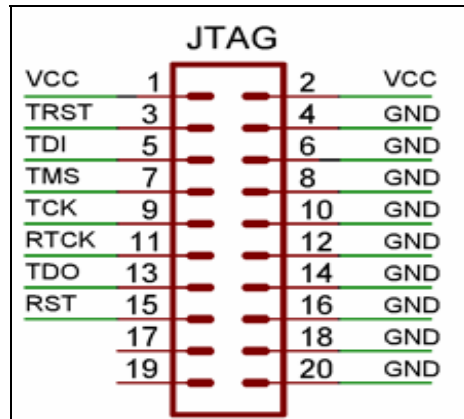
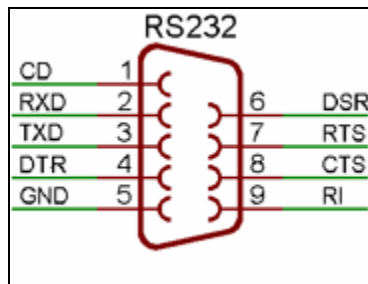

**Figure 5: JTAG Connector**

Pin/ Name	Connected to	Functionality
1 – VCC	VCC	-
2 – VCC	VCC	-
3 – TRST	Pin 20	P1.31/ TRST
4 – GND	Ground	-
5 – TDI	Pin 60	P1.28/TDI
6 – GND	Ground	-
7 – TMS	Pin 52	P1.30/TMS
8 – GND	Ground	-
9 – TCK	Pin 56	P1.29/TCK
10 – GND	Ground	-
11 – RTCK	Pin 24	P1.26/RTCK
12 – GND	Ground	-
13 – TDO	Pin 64	P1.27/TDO
14 – GND	Ground	-
15 – RST	Pin 57	RST

16 – GND	Ground	-
17 --	Not Connected	-
18 – GND	Ground	-
19 --	Not Connected	-
20 – GND	Ground	-

## 2.5 RS232 Connector



**Figure 6: RS232 Connector**

Pin / Name	Connected to	Functionality
1 – CD	Not Connected	-
2 – RXD	Pin 19	P0.0/TXD0/PWM1
3 – TXD	Pin 21	P0.1/RXD0/PWM3/EINT0
4 – DTR	JRST	External Reset Control
5 – GND	Ground	-
6 – DSR	Not Connected	-
7 – RTS	Not Connected	-
8 – CTS	Not Connected	-
9 – RI	Not Connected	-

## 2.6 UART Connector

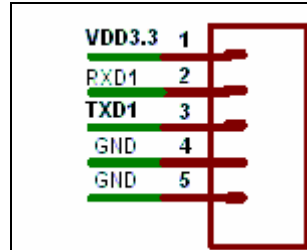

**Figure 7: UART Connector**

Pin / Name	Connected to	Functionality
1 – VDD3.3	VCC	Power Supply
2 – RXD1	Pin 34	P0.9/RXD1/PWM6/EINT3
3 – TXD1	Pin 33	P0.8/TXD1/PWM4/AD1.1
4 – GND	Ground	-
5 – GND	Ground	-

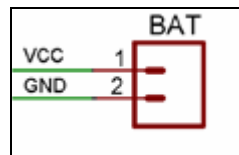

## 2.7 Battery Connector









**Figure 8: Battery Connector**

Pin / Name	Connected to	Functionality
1 – VCC	Pin 49	VBAT
2 – GND	Ground	-

## 2.8 Jumpers

Jumpers	Position	Description
Jumper 1 (JRST)		Disable External Reset
		Enable External Reset

Jumper 2 (DBG)		Disable JTAG Programming
		Enable JTAG Programming
Jumper 3 (BAT)		Disable Battery Supply
		Enable Battery Supply
Jumper 4 (B2S)		Disable boot loader
		Enable boot loader

## 2.9 WLAN SPI Connector

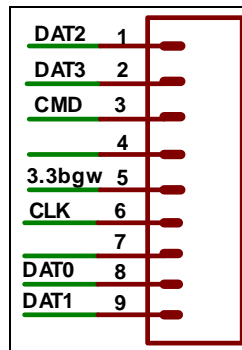
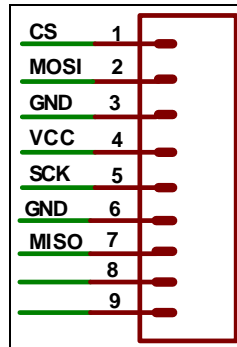

Figure 9: WLAN SPI Connector

Pin / Name	Connected to	Functionality
1 – DAT2	Pin 26	PO.3/SDA0/MAT0.0/EINT1
2 – DAT3	Pin 35	PO.10/RTS1/CAP1.0/AD1.2
3 – CMD	Pin 30	PO.6/MOSI0/CAPO.2/AD1.0
4	Ground	–
5 – 3.3bgw	U5 Drain	Switch BGW
6 - CLK	Pin 27	PO.4/SCK0/CAPO.1/AD0.6
7	Ground	–
8 – DAT0	Pin 29	PO.5/MISO0/MAT0.1/AD0.7
9 – DAT1	Pin 22	PO.2/SCL0/CAPO.0

## 2.10 SD Memory Connector



**Figure 10: SD Memory Connector**

Pin / Name	Connected to	Functionality
1 – CS	Pin 46	P0.16/EINT0/MAT0.2/CAP0.2
2 – MOSI	Pin 54	P0.19/MAT1.2/MOSI1/CAP1.2
3 – GND	Ground	-
4 – VCC	VCC	Power Supply
5 – SCK	Pin 47	P0.17/CAP1.2/SCK1/MAT1.2
6 – GND	Ground	-
7 – MISO	Pin 53	P0.18/CAP1.3/MISO1/MAT1.3
8 – RSV	Pulled Up	Reserved
9 – RSV	Pulled Up	Reserved

## 2.11 Additional Connectors

The development kit also exposes pin headers for several other components of LPC2138 to easily integrate the kit for a wide range of applications. The different interfaces are 10 general-purpose input outputs (GPIO), 8 ADC channels and 1 DAC channel. All these pins are 3.3V tolerant.



### 3. REPROGRAMMING THE FLASH MEMORY

It is assumed that the program to be downloaded is already developed and there exists a hex file to be downloaded. This hex file represents the binary image of the application program.

LPC2xxx microcontroller provides on-chip boot loader software that allows programming of internal flash memory over serial interface. The WLAN Application Development Kit contains circuit to automatically provide RESET facility through Philips ISP utility.

The utility program for In System Flash Programming (ISP) provided by Philips is called LPC2000 Flash Utility. Make sure you have access to the program before moving ahead.

Run the LPC2000 Flash Utility program. The program looks like Figure 11 below.

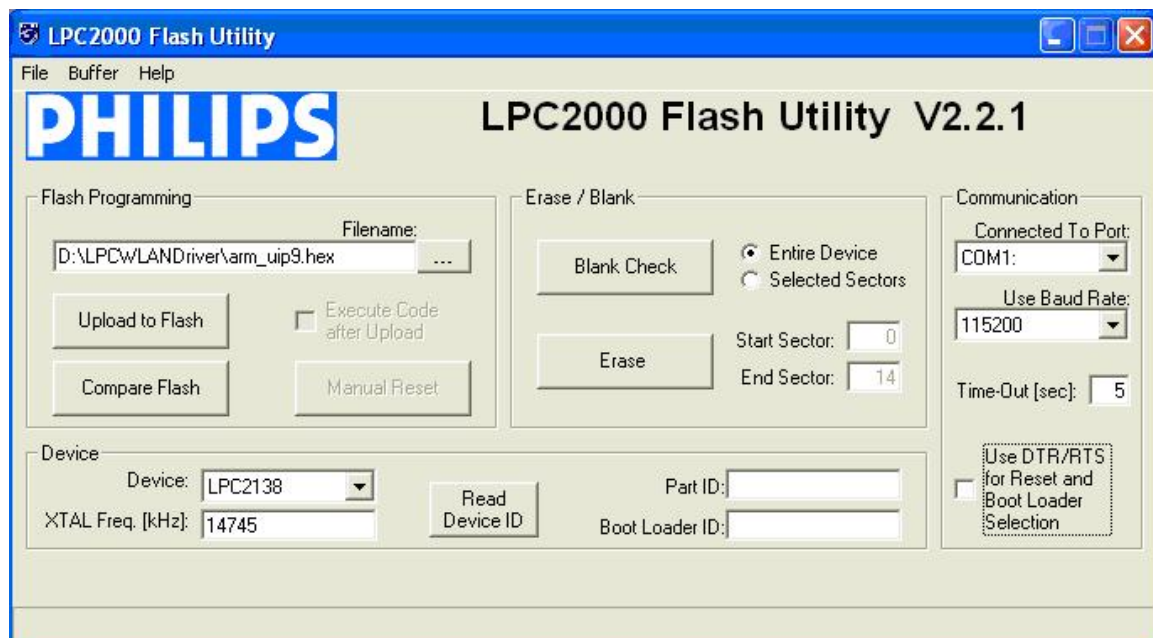

**Figure 11: Settings for LPC2000 Flash Utility**

Configure the dialog as shown in the figure.

**Note:**

- Select the COM port that is connected to the LPCWLAN Development Kit.
- In the device edit box select LPC2138.
- In the XTAL Freq. [kHz] box, give value 14745.

**The WLAN Development kit BL jumper (jumper at P4) should be connected. The kit should be restarted by pressing the reset button S1 or On/Off switch.**

On the LPC 2000 Flash Utility dialog box click on the Read Device ID button. If the device is connected, it will show the Part ID and Boot Loader ID of the device. Select the hex file to download in the Filename edit box. Click on the Upload Flash button to download the hex file to the development kit.

Once the flash upload is completed successfully, remove the BL jumper (jumper at P4) and reset or switch Off/On the device. The device will now execute from the flash.

### 3. LINKS FOR REFERENCE

1. Philips Web Site  
LPC2138 Product datasheets, application notes etc info:  
<http://www.semiconductors.philips.com/markets/mms/products/microcontrollers/index.html>
2. LPC Microcontrollers Discussion Forum  
<http://groups.yahoo.com/group/lpc2000/> – Forum for discussions on  
LPC2000 ARM microcontrollers