ATA6286-EK3 Active RFID Evaluation Kit

ATAN0057

Description

This document outlines the procedure for evaluating an active RFID tag system consisting of 1) a base station configured as an LF transmitter 2) a base station configured as an RF receiver and 3) an active RFID tag.

The base station is used to transmit LF (100kHz-150kHz) ASK-modulated data and receive RF (434MHz) ASK/FSK-modulated data from the RFID tag. The RFID tag is an active portable ultra-low-power RFID device powered by a 3.3V coin cell battery. It is used to receive LF signals generated by the base station from up to 2m away (depending on the LF trigger antenna size) from the transmitting LF antenna. The tag also transmits an RF message to the base station reporting fob ID, measured RSSI, and other sensor data.

The fob, once powered, continuously monitors the LF frequency in ultra-low-power mode. Once a valid signal is detected containing the correct device ID, the fob wakes up, processes LF input data, and responds to the base station by sending the RF message with application payload. Once the transmission is complete it returns to its ultra-low-power sleep state and resumes monitoring the LF channel for a new message.

The LF and RF signal transmission uses a custom signaling protocol. Each of the protocols is unique and includes its specific preamble, header, payload, and CRC (data integrity) fields.

This RFID system allows the use of multiple tags in field operation by incorporating anticollision protocol support. A slotted ALOHA anticollision protocol has been implemented for these applications. In case of a reception error on the RF channel (more than one device transmitting at a time), the error is sent from the RF receiver module via the UART cable to the LF module. The LF module must then re-transmit the LF message which allows individual tags to choose a new arbitrary slot (one of any other seven slots) when sending the RF message response. Anticollision RF message return time slots are chosen randomly by the tag.

This active 125kHz RFID system can be easily used in areas such as inventory and item monitoring applications.

1. Overview

Thank you for your interest in the Atmel active RFID product line. For space and environmental reasons the documentation and PC GUI software is no longer distributed on CD-ROM. This includes datasheets, application notes, schematics and BOMs, and source code for the Atmel® ATA6286-EK3 kit. This also ensures that you always have access to the most up-to-date information.

Send an email to the Email address below to get access to the Atmel RFID FTP server:

rfidsupport@atmel.com

You will automatically added to a mailing list to receive updates regarding our devices or tools. If you do not wish to be added, please mention that in the mail.

1.1 Implementation

The active RFID systems use an LF downlink to send a wake-up signal (and payload data) to the RFID fob and an RF uplink link to transmit acknowledgement and payload data from the active LFID tag to the UHF receiver.

The Atmel ATA6386-EK3 evaluation kit includes a

- Base station LF transmitter module.
 - Atmel ATA2270-EK1/EK2 controller board. It includes the Atmel ATmega128 MCU and a user interface, i.e., LCD, joystick, function keys, and a switch)
 - Atmel ATAB5279B-V1.2 LF transmitter board. It includes the Atmel ATA5279C LF driver IC, external driver components
- Base station UHF receiver module:
 - Atmel ATA2270-EK1/EK2 controller board. It includes the Atmel ATmega128 MCU and a user interface, i.e., LCD, joystick, function keys, and a switch)
 - Atmel ATAB8202A-V1.0 UHF receiver board. It is based on the Atmel ATA8202 RF receiver (434MHz).
- Atmel ATAB6286A active RFID tag (434MHz):
 - It is based on the Atmel ATA6286 SoC active RFID device consisting of an AVR® MCU, LF receiver, 433.92MHz RF transmitter, a temperature sensor, and many other peripherals. Two are included to demonstrate anticollision.
- Null modem DB9 female-to-female 6' cable
- Two DB9 mini gender changers
- Two DC 12 VDC, 800mA power supply and adapters
- Two Premo LF 125kHz antennas (KGEA-B-FCWX-B-0345J)
- A UHF 433MHz - ¼ wave-fixed antenna

Figure 1-1 shows an active RFID system diagram as it is implemented by the Atmel ATA6286-EK3 development kit.

Figure 1-1. Atmel ATA6286-EK3 Development Kit System Diagram

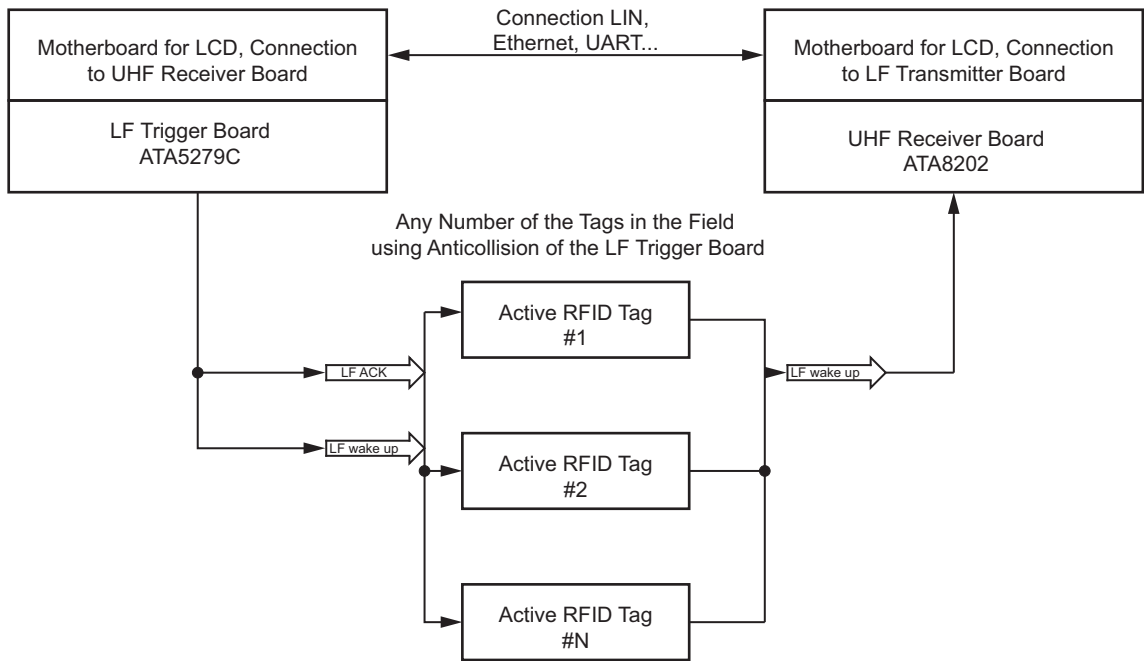

Figure 1-2. Atmel ATA6286-EK3 Development Kit

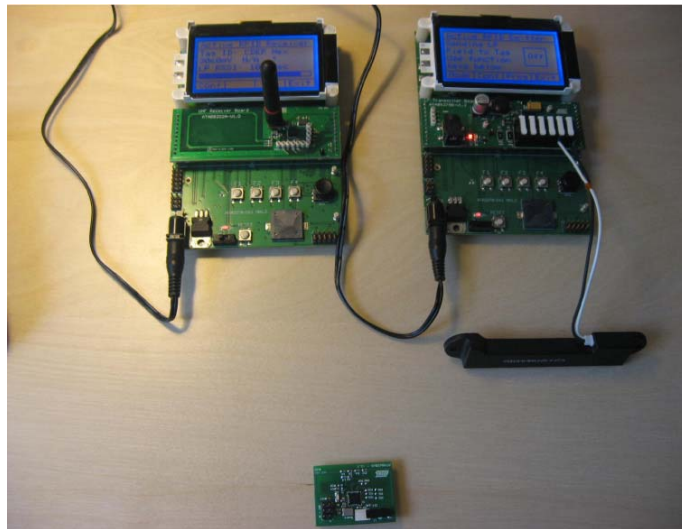
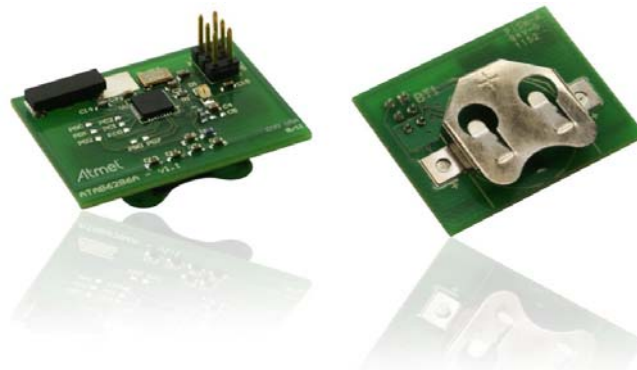

Figure 1-3. Atmel ATA6286-EK3 Development Kit Tag



2. LF Driver Board Description

2.1 Hardware Connection

The LF driver node consists of two PCB modules. Please mount the Atmel® ATAB5279B LF transmitter board (top card) to the top of the Atmel ATA2270-EK1/EK2 controller board. See [Figure 2-1](#) for the correct orientation of the top card.

Connect one or more of the antenna coil wires to the antenna driver snap-on clamps. As shown in [Figure 2-1](#), antenna 1 starts on the far right side.

Attach the power supply connector to the top card in order to supply the LF drive with up to 1A. This is very important because if the wrong power plug is used the LCD will work but operation of the system may be adversely affected.

Slide the power switch to the ON position (left side) to power on the board assembly.

See [Figure 2-1](#) for the correct top card, antenna cable, and power supply connections.

Figure 2-1. LF Driver Board Assembly

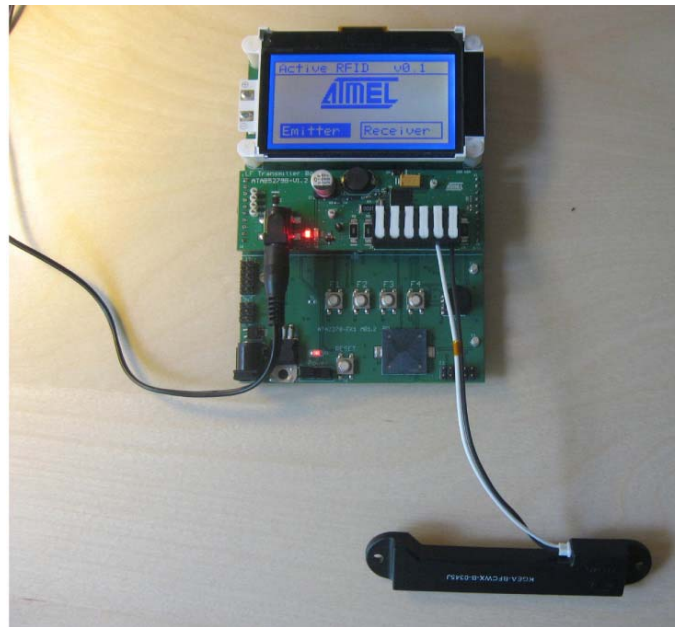

2.2 Using the LCD to Control the LF Driver Board

Once the hardware is connected and the power switch is in the ON position, the LCD menu is activated by pushing the RESET button.

Use the joystick on the LF driver board to highlight the Emitter menu and press the joystick once to activate it. This changes the LCD display to the Active RFID Emitter menu with the rectangular “On”/“Off” box flashing—the LF driver runs in a polling loop that transmits the LF signal using the attached LF coil(s) to the tag. This is the “Normal Mode” discussed in detail below.

Figure 2-2 on page 5 shows a top-level LCD-active RFID emitter’s Sending LF Field to Tag operating menu. A sub-menu can be selected using F1, F2, or F3 function keys. Press the F4 key to exit the Emitter menu.

Figure 2-2. LF Driver Top-Level LCD Menu



2.2.1 Selecting the Operating Mode (Mode) Sub-Menu

The Mode menu can be activated by pressing the appropriate F1 switch on the motherboard. This allows the selection between the two operating modes of the system.

In the Mode menu move the joystick up or down and press it to make a mode selection either as:

1. “Mode 1” - normal mode (anticollision protocol is disabled). LF baud rate = 3.9Kbaud. RF baud rate = 9.6Kbaud.
2. “Mode 2” - anticollision mode (anticollision protocol is enabled). The null modem cable between the RF and LF modules must be connected.

Press F4 to exit this menu.

2.2.2 Selecting the Configuration (Conf) Sub-Menu

The Conf menu can be activated by pressing the appropriate F2 switch on the motherboard.

In the Emitter Conf menu move the joystick up or down and press it to change the configuration settings for the following parameters:

1. Header: This is used by the tag to screen out noise and only wake up from low-power mode when a matching header is found. This header value should be identical for all tags in the application. The demo uses 0x2B as the default value.
2. ID: In some modes, this ID is sent in order to directly address only one tag at a time. All tags wake up from the header but they ignore messages that are not directed to their ID.
3. Max Antennas: This indicates how many LF antennas are used in messaging. It can be set from 1 to 3 antennas. These antennas should be used either to provide orientation coverage or to extend the wake-up range by spacing them out to enlarge the total area.
4. Output Power: The current driven through each antenna can be selected within a range of 50mA to 1000mA. This is changed in 50mA increments.
5. Battery Sens: This determines if the battery voltage is requested to be sent in the response from the tag.
6. Temp Sens: This specifies if the temperature of the tag is requested as part of the LF message command.
7. Sens 3: This provides a placeholder for an additional sensor to be requested from the tag.
8. Sens 4: This provides a placeholder for an additional sensor to be requested from the tag.
9. Sound: This controls the sounds on this mainboard.

The value of each configuration option (upon being selected by navigating the cursor to the current value) can be changed by moving the joystick up or down to choose a desired setting. Pressing the center button on the joystick sets the value.

Exit the configuration menu at any time by pressing the F4 key.

Figure 2-3. LF Driver Board Configuration Menu (E.G., Setting Output Power to 650mA)



3. RF Receiver Board Description

3.1 Hardware Connection

The RF receiver board consists of two PCB modules. Please mount the Atmel® ATAB8202A UHF receiver board (top card) on top of the Atmel ATA2270-EK1/EK2 controller board (the motherboard).

Attach the RF antenna to the screw-on SMA connector on the top card.

Attach the power supply connector to the motherboard.

Slide the power switch to the ON position (to the left side) to power the board assembly.

See [Figure 3-1](#) for the correct top card, antenna cable, and power supply connections.

Figure 3-1. RF Receiver Board Assembly



3.2 Controlling the RF Receiver Board Using the LCD Menu

Once the hardware is connected and the power switch is in the ON position the LCD menu is activated by pressing the RESET button.

Use the joystick on the RF receiver module to highlight the Receiver menu rectangle and press the joy stick once to activate it. This changes the LCD display to the Active RFID Receiver menu with Active RFID Receiver text displayed at the top of the LCD.

The configuration parameters can be changed using the F1 key and selected using the joystick:

- Temperature [°C/°F]
- Receiver mode [polling/active]
- Mode [normal/anticollision]
- Sound [ON/OFF]

Figure 3-2. The RF Receiver Board Configuration Menu



4. Communication Protocol Implementation

The LF channel which is used for sending data from the LF transmitter to the RFID tag supports unidirectional data transmission. It is used to address any tag in the LF field range by providing a synchronizing pattern and tag address information.

The following depicts a typical LF downlink message:

- LF preamble (synchronization period, T = 2.048ms)
- Start gap (synchronization period, T = 1.024ms)
- Wake-up header (1byte, T = 2.048ms)
- ID (2bytes, T = 4.096ms)
- Command field (normal operation, 1byte, T = 2.048ms)
- Continuous LF field (RSSI measurement interval, T = 2.048ms)

The RF channel is used to return payload data from the RFID tag to the base station. The following fields make up the return RF message:

- RF preamble (1 byte in USART sync mode, 16 bytes in polling mode, used for synchronizing the RF receiver)
- UID value (16-bit, fob UID value)
- RSSI value (8-bit, fob measured LF field RSSI value)
- Temperature data (fob measured temperature)
- VBAT value (measured battery voltage of tag)
- Sensor value (reserved for other future sensor values)
- 8-bit CRC value (cyclic redundancy check or data integrity checksum)

Shown below is a typical sequence in normal mode. This shows all phases of the communication but does not show the breakdown of individual message content.

Figure 4-1. Typical Sequence in Normal Mode

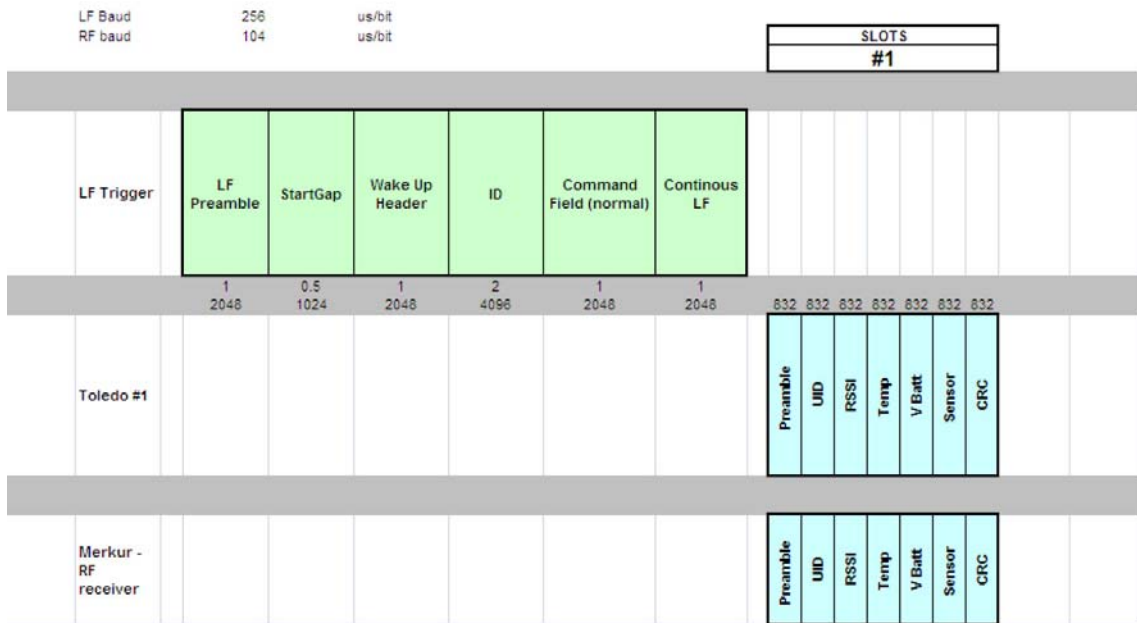
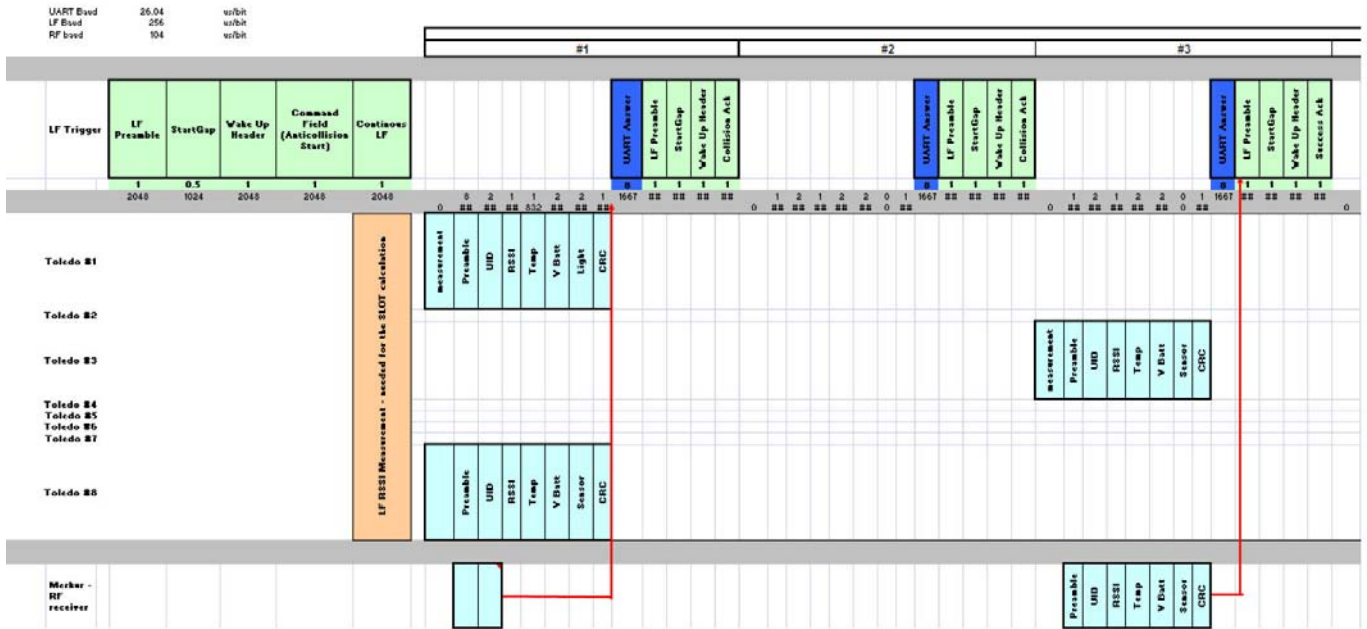

Figure 4-2 shows one possible iteration of messages for an anticollision mode sequence. Note that the message changes slightly depending on the value in the command field. In this sequence you can see that Tag #1 and Tag #8 have a collision. This would result in a negative acknowledgment message being sent back. Tag #3 however completes the RF message successfully. The LF emitter module would then repeat the sequence due to the detected collision and Tag #1 and Tag #8 would pick new time-slots to transmit on. This would likely result in successful communication on this second round.

Figure 4-2. Possible Iteration of Messages



The type of message and consequently the tag reaction to the LF message is determined by the command byte. This is broken into two parts, the command and the sensor control. The possible values this can take is shown below.

Figure 4-3. Possible Values

	Data Payload							
	Byte 1							LSB
	MSB	7	6	5	4	3	2	
Normal Mode	0	0	0	0	x	x	x	x
Anti-Collision Start Mode	0	0	0	1	x	x	x	x
Anti-Collision Continue Mode	0	0	1	0	x	x	x	x
Programming Mode	0	1	0	0	x	x	x	x
Programming Mode Start	0	1	0	1				
Acknowledge Ack P	1	1	1	1				
Acknowledge Ack N	1	0	0	0	x	x	x	x
Sensor 3 Off	x	x	x	x	x	x	x	0
Sensor 3 On	x	x	x	x	x	x	x	1
Sensor 4 Off	x	x	x	x	x	x	0	x
Sensor 4 On	x	x	x	x	x	x	1	x
Temp Off	x	x	x	x	x	0	x	x
Temp On	x	x	x	x	x	1	x	x
Batt Off	x	x	x	x	0	x	x	x
Batt On	x	x	x	x	1	x	x	x

Please note that programming mode is not implemented yet. This makes it possible to program new values into the tag via the LF field. This will be supported in a future release.

5. Performing RFID Measurements

Depending on the application requirements two modes can be used:

- Normal mode: Supports one RFID device in the field. This mode is designed to provide a continuously polling base station that allows LF and RF ranges to be conveniently tested. For example, this would allow an LF field map to be created for testing a specific application. In addition, the RSSI range measurement, temperature, and battery voltage can be varied and viewed on the RF receiver display. This mode is the first step in beginning to evaluate the active RFID system.
- Anticollision mode: Supports multiple devices in the field. This goes more into detail about how to create a system that would allow multiple tags to interact with the base station hardware. This does not run in “real time” but instead operates on a triggered basis with the LF emitter module acting as the master.

In both of these modes, the LF field can be adjusted to fit the specific needs of the application. This adjustment primarily entails varying the orientation and strength of the field. Orientation of the LF field is controlled by driving different coils that are aligned on a perpendicular axis. It is very important to note that the tag device has only a single-axis LF antenna. Because this system operates on a magnetic field, it is very sensitive to orientation of the LF emitter antenna and tag receiver antenna. For optimal performance, these must be aligned in parallel. To allow the tag to always be aligned with a base station antenna, the LF emitter module can drive three different antennas. These could be positioned in the X, Y and Z axis. For simplicity we include two antennas and suggest using them in the X and Y axis. This provides nearly complete coverage of all orientations. If any gaps in coverage are noted, a third antenna could be used as well.

The magnetic field strength from each antenna is primarily set by the number of turns on the coil and the current passing through the antenna. The turns are fixed for our antennas but the current is programmable. In the configuration options, the current can be adjusted in 50mA increments up to a maximum of 1000mA. This shifts the range in which the tag will wake up from the LF message. Through the tuning of multiple emitter antenna and field strength, a desired coverage area can be determined for the specific application.

5.1 Normal Operating Mode

The RFID active tag system can be easily tested as follows:

1. Assemble and power up the LF emitter board (see [Section 2. “LF Driver Board Description” on page 4](#)). Use the default values for the LF mode:
 - a. Mode: “Mode 1” - normal mode
 - b. Configuration parameters: Header=0x2B, ID=0xCDEF, Max Antennas=1ch, Output Power=500mA, Battery Sense=ON, Temp Sense=ON, Sound=ON
2. Assemble and power up the RF receiver board (see [Section 3. “RF Receiver Board Description” on page 7](#)). Use the default values for the RF node:
 - a. Receiver Mode = active,
 - b. Mode = normal
 - c. Sound = ON
3. Insert a battery cell into the tag. The tag powers up and listens for a new LF message.
4. Approximately every 1s the LF emitter module transmits a new LF message.
5. The tag wakes up from low-power listen mode and sends back the RF response.
6. The buzzer on the RF receiving module goes off when a new RF message arrives. The UID, temperature, battery voltage, and the LF field RSSI values sent from the tag are displayed on the LCD.
7. The system repeats in a loop from step 4.

Note: If more than one LF antenna is selected in the “Conf” options, the LF message in step 4 is repeated on all antennas.

Figure 5-1. Operating Kit in Normal Mode

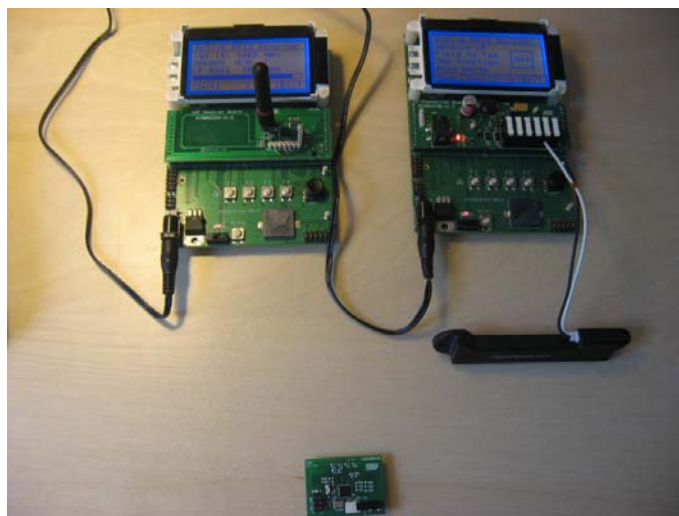

5.2 Anticollision Operating Mode

In situations when more than one RFID tag is in the field, the system must be configured in anticollision mode as follows:

1. Assemble and power up the LF emitter board (see [Section 2. “LF Driver Board Description” on page 4](#)). Use the following values for the LF mode
 - a. Mode: Mode 2 - anticollision
 - b. Configuration parameters: Header=x2B, ID=CDEF, Max Antennas=1ch, Output Power=500mA, Battery Sense=ON, Temp Sense=ON, Sens 3=OFF, Sense 4=OFF, Sens 4=OFF, Sound=ON
2. Assemble and power up the RF receiver board (see [Section 3. “RF Receiver Board Description” on page 7](#)). Use the default values for the RF node:
 - a. Receiver mode = active,
 - b. Mode = anticollision
 - c. Sound = ON
3. Use the null modem cable to connect the LF and RF motherboards when used in anticollision mode. This allows the two UARTs to communicate correctly.
4. Insert batteries into both tags. The tags both listen for a new LF message.
5. While the LF emitter module is set to anticollision mode, use the joystick to select and press the “Search” option. This sends the starting LF wake-up message which contains a flag so that ALL tags that hear this message go into the unacknowledged state.
6. The LF emitter module then sends an LF message that begins the anticollision process. It also alerts the RF receiver module to begin checking the RF time slots.
7. All tags that hear the LF message respond using the anticollision algorithm, pick a random time slot, and transmit the RF message in this time slot. After this they listen for an acknowledgement.
8. The RF receiver receives the RF message sent for each time slot. The results are displayed on the RF receiver’s module LCD. Additionally, a message is sent to the LF emitter module letting it know that a tag was found. The contents of the RF message are also sent.
9. The LF emitter module sends an LF message at the end of every time slot. This acknowledgement is positive if a valid RF message was detected in that time slot and is negative for empty slots or collisions.
10. The tag that transmits in a given time slot and receives a positive acknowledgement transitions into a quiet state until a new LF message indicates the unacknowledged state has resumed.
11. The LF emitter repeats from step 6 in a loop until all time slots are completed without any collisions being detected.

Note: If more than one LF antenna is selected in the “Conf” options, the starting LF message in step 5 is repeated on all antennas. After this, steps 6 to 10 are repeated on each antenna in series.

Figure 5-2. Operating Kit in Anticollision Mode

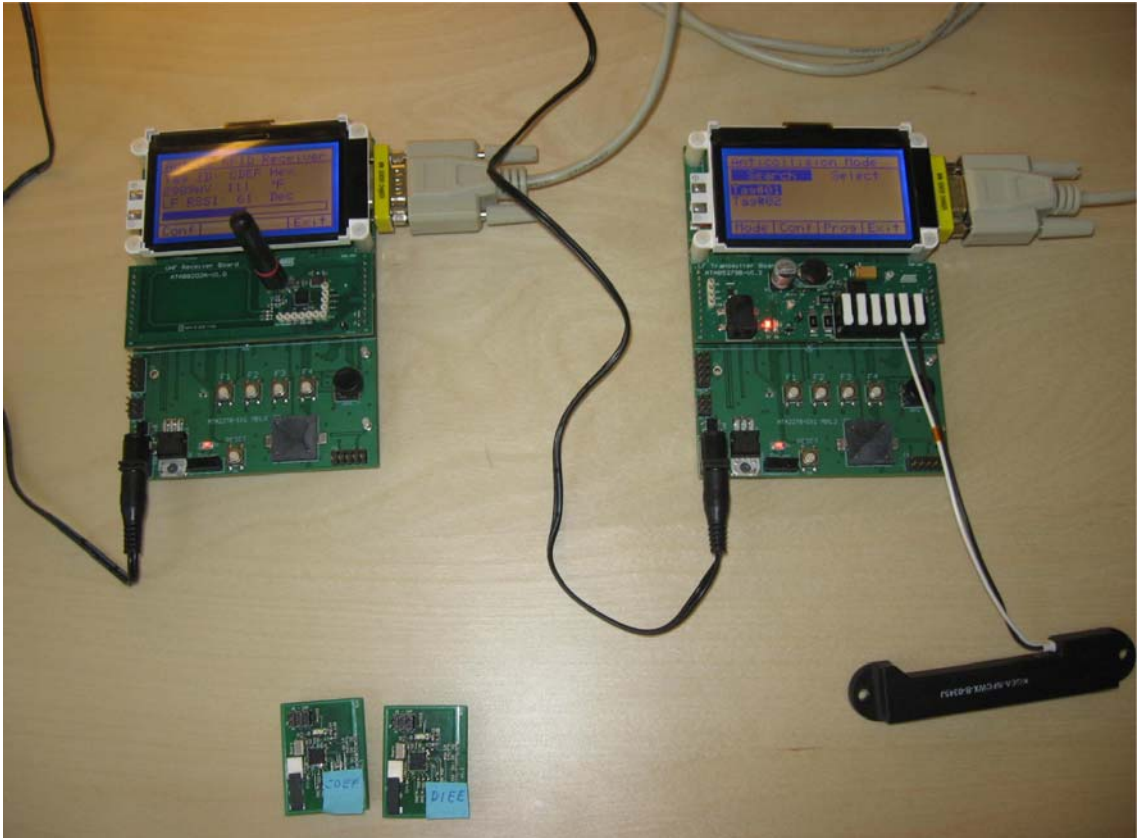

The null modem cable provides a bidirectional serial interface between the LF and the RF modules of the base station. It is used for synchronization of the LF and RF channel data in anticollision mode and also transfers the received data back to the LF emitter module which is acting as the master. This received data is buffered and held for recovery and displayed on the LF emitter module display.

Make sure that two active RFID tags are placed in the LF field and both are detected as shown on the display of the LF transmitter module (see [Figure 5-2](#)). The LCD display is structured so that up to 9 tags can be found. The system is designed to handle more than this but for the demo we have limited the scope. If both tags receive the LF wake-up signal and transmit their response on the RF channel in the same time slot, creating a “data collision,” an error message is sent to the tags using the LF channel. In this case each node attempts to send its RF response again in the different randomly chosen time slot after each LF message. Once the RF response arrives cleanly the acknowledge message is sent on the LF channel.

The Active RFID system shown above uses two active RFID devices, device #01 and device #02. Each device is pre-programmed with its unique device ID, i.e. device #01 ID is set to “CDEF” and device #02 ID is set to “D1EE” hex value. The device #01 ID value is displayed on the RF receiver module (see [Figure 5-2](#)).

Figure 5-3. Anticollision Mode Device Search Results



When the Search menu is selected on the LF transmitter module and the joystick is pressed, the LF transmitter sends an LF broadcast message which is also accompanied by a single beep signal on the LF transmitter. Active RFID devices respond by sending their RF responses. Each successful reception triggers a short beep signal by the RF receiver module. The RF receiver module LCD shows the last received active RFID tag response indicating that the device ID, VBAT, temperature, and RSSI are displayed on the LCD.

Once all the tags have been found and displayed on the LF emitter module LCD, the associated data for each tag can be recalled and displayed. Simply navigate to the right using the joystick to highlight the select function. Then navigate up or down to the desired tag # and press the center button of the joystick. The message payload for that tag is displayed. Press the F4 (Exit) button to return to the found tag list. In this way, the data from all tags can be recovered.

6. Programming/Upgrading Device Firmware

Support for the devices in this kit is contained in AVR Studio®6. Programming is possible by using a number of different tools such as STK600, JTAGICE3, JTAGICE mkII, or AVR® Dragon. For illustration purposes, the example described below uses the JTAGICE3 programming with AVR Studio 6.

6.1 Programming the Atmel ATA2270-EK1/EK2 Mainboard

The Atmel® ATA2270-EK1/EK2 MainBoard ATmega128 can be programmed using ISP or JTAG ports.

Follow these steps below when programming the board:

1. After removing the top card from the ATA2270-EK1/EK2 mainboard, connect the JTAGICE3 connector to the 6-pin ISP connector on the mainboard.
2. Connect the power cable and switch the PCB power on.
3. Switch the JTAGICE3 on.
4. Launch the AVR Studio 6 software.
5. Select the “Tools” button in the Studio toolbar.
6. Select “Device Programming/Interface settings” and populate the appropriate fields as shown in [Figure 6-1](#).
7. Select “Device Programming/Fuses” and ensure the fuses are programmed as shown in [Figure 6-2](#).
8. Select “Device Programming/Memories” and browse to the appropriate files containing Flash and EEPROM.

Figure 6-1. JTAGICE3 Interface Settings for Mainboard

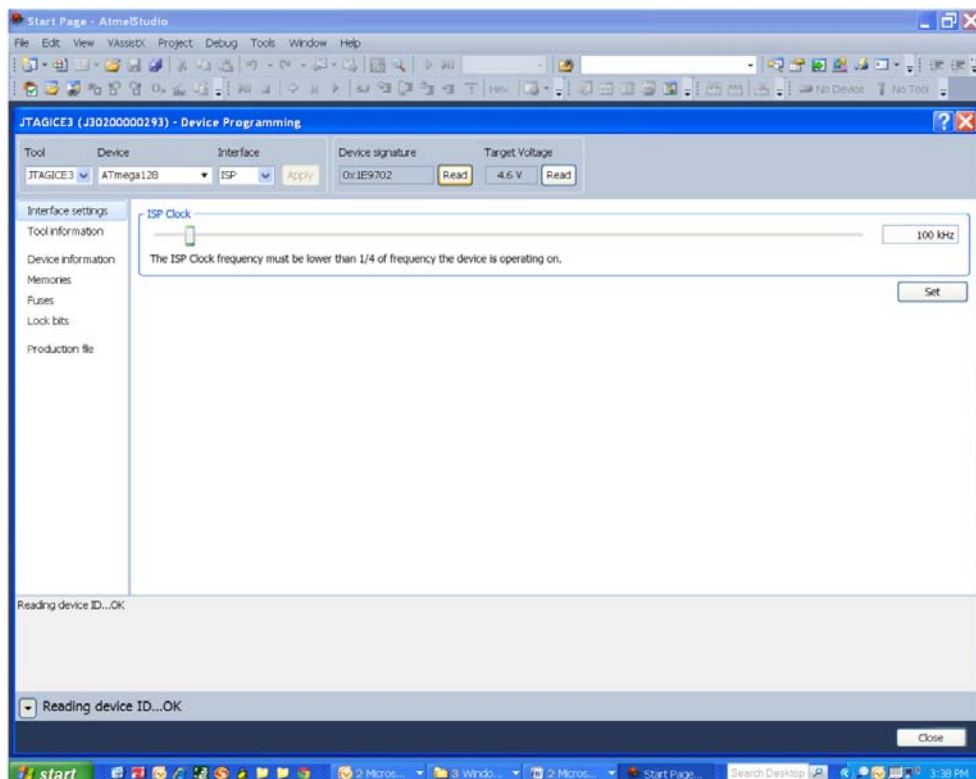
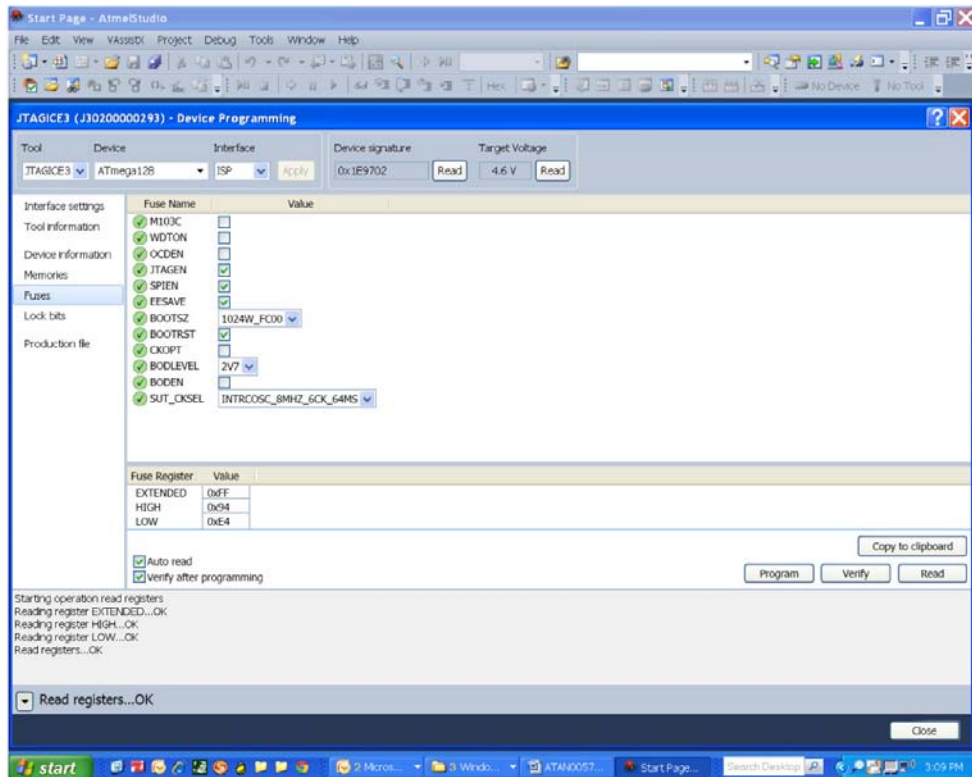

Figure 6-2. JTAGICE3 Fuse Settings for Mainboard



6.2 Programming the ATAB6286A RFID Tag

The Atmel® ATAB6286A RFID board PCB can be programmed using the ISP port. Follow the steps below when programming the board:

1. Insert a coin cell battery into the PCB making sure the polarity (+ faces away from PCB) is properly aligned.
2. Connect the ISP cable to the 6-pin ISP connector on the Atmel ATAB6286A PCB.
3. Launch the AVR Studio® 6 software.
4. Select the “Tools” button in the Studio toolbar.
5. Select “Device Programming/Interface settings” and populate the appropriate fields as shown in [Figure 6-3](#).
6. Select “Device Programming/Fuses” and ensure the fuses are programmed as shown in [Figure 6-4](#).
7. Select “Device Programming/Memories” and browse to the appropriate files containing Flash and EEPROM.

Figure 6-3. JTAGICE3 Interface Settings for RFID PCB

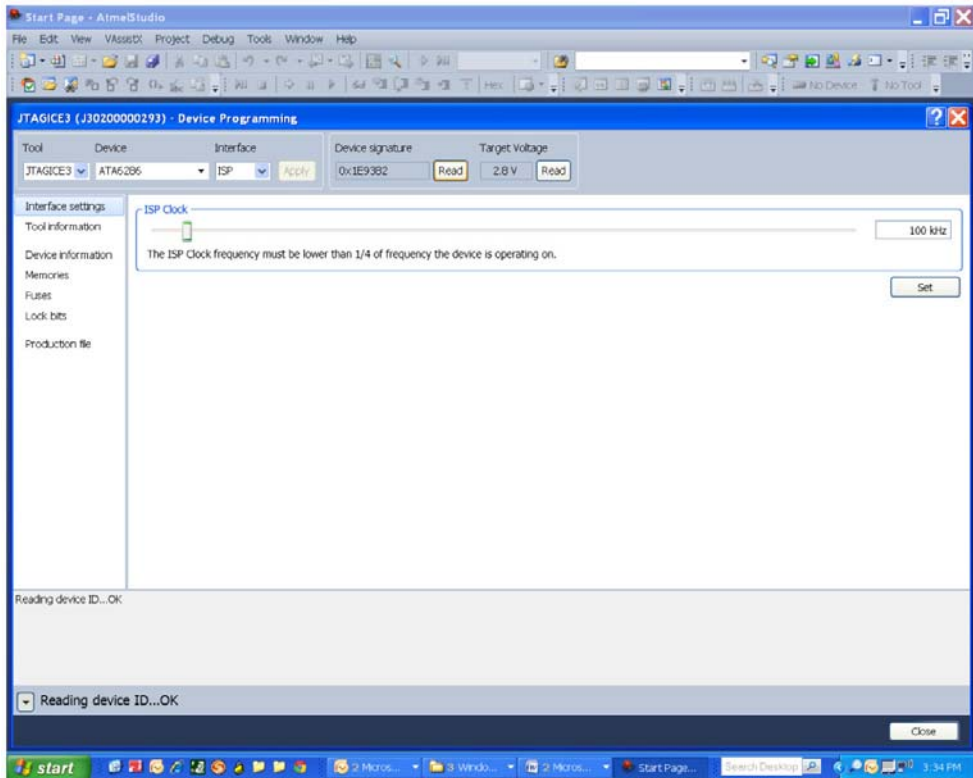
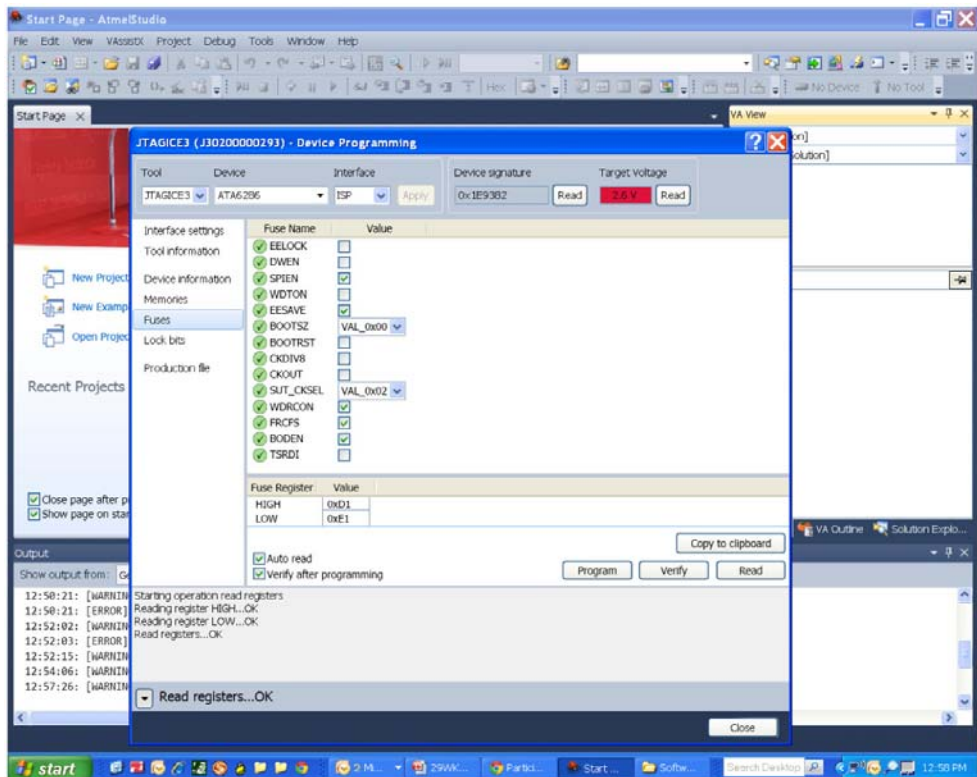

Figure 6-4. JTAGICE3 Fuse Settings for RFID PCB



7. Revision History

Please note that the following page numbers referred to in this section refer to the specific revision mentioned, not to this document.

Revision No.	History
9289D-RFID-03/15	<ul style="list-style-type: none">• Put document in the latest template
9289C-RFID-03/13	<ul style="list-style-type: none">• Section 1 “Overview” on page 2 updated

Atmel®, Atmel logo and combinations thereof, Enabling Unlimited Possibilities®, AVR®, and others are registered trademarks or trademarks of Atmel Corporation in U.S. and other countries. Other terms and product names may be trademarks of others.

DISCLAIMER: The information in this document is provided in connection with Atmel products. No license, express or implied, by estoppel or otherwise, to any intellectual property right is granted by this document or in connection with the sale of Atmel products. EXCEPT AS SET FORTH IN THE ATMEL TERMS AND CONDITIONS OF SALES LOCATED ON THE ATMEL WEBSITE, ATMEL ASSUMES NO LIABILITY WHATSOEVER AND DISCLAIMS ANY EXPRESS, IMPLIED OR STATUTORY WARRANTY RELATING TO ITS PRODUCTS INCLUDING, BUT NOT LIMITED TO, THE IMPLIED WARRANTY OF MERCHANTABILITY, FITNESS FOR A PARTICULAR PURPOSE, OR NON-INFRINGEMENT. IN NO EVENT SHALL ATMEL BE LIABLE FOR ANY DIRECT, INDIRECT, CONSEQUENTIAL, PUNITIVE, SPECIAL OR INCIDENTAL DAMAGES (INCLUDING, WITHOUT LIMITATION, DAMAGES FOR LOSS AND PROFITS, BUSINESS INTERRUPTION, OR LOSS OF INFORMATION) ARISING OUT OF THE USE OR INABILITY TO USE THIS DOCUMENT, EVEN IF ATMEL HAS BEEN ADVISED OF THE POSSIBILITY OF SUCH DAMAGES. Atmel makes no representations or warranties with respect to the accuracy or completeness of the contents of this document and reserves the right to make changes to specifications and products descriptions at any time without notice. Atmel does not make any commitment to update the information contained herein. Unless specifically provided otherwise, Atmel products are not suitable for, and shall not be used in, automotive applications. Atmel products are not intended, authorized, or warranted for use as components in applications intended to support or sustain life.

SAFETY-CRITICAL, MILITARY, AND AUTOMOTIVE APPLICATIONS DISCLAIMER: Atmel products are not designed for and will not be used in connection with any applications where the failure of such products would reasonably be expected to result in significant personal injury or death ("Safety-Critical Applications") without an Atmel officer's specific written consent. Safety-Critical Applications include, without limitation, life support devices and systems, equipment or systems for the operation of nuclear facilities and weapons systems. Atmel products are not designed nor intended for use in military or aerospace applications or environments unless specifically designated by Atmel as military-grade. Atmel products are not designed nor intended for use in automotive applications unless specifically designated by Atmel as automotive-grade.